

TECHNICAL MANUAL

**OPERATOR'S, UNIT, AND DIRECT SUPPORT  
MAINTENANCE MANUAL INCLUDING  
REPAIR PARTS AND SPECIAL TOOLS LIST**

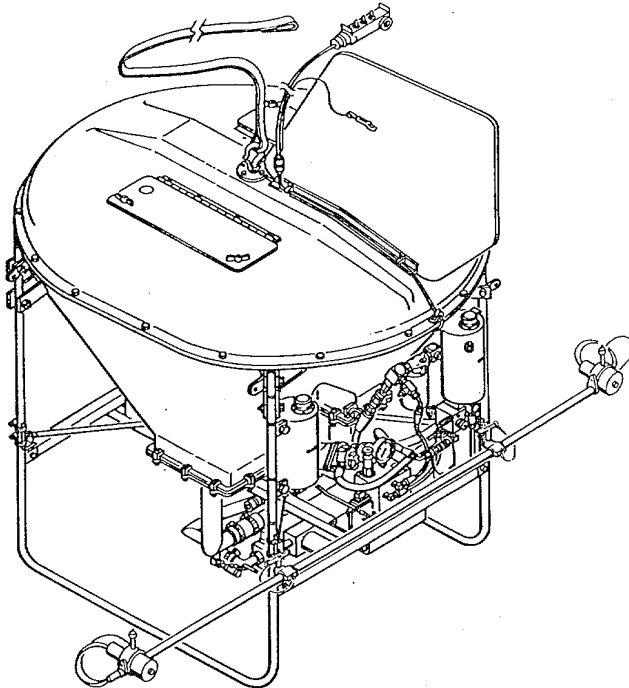

**PESTICIDE DISPERSAL UNIT,  
MULTICAPABILITY, HELICOPTER SLUNG**

**(NSN 3740-01-262-8707)**

Approved for public release; distribution is unlimited.

**EQUIPMENT DESCRIPTION  
AND DATA**

**OPERATOR'S CONTROLS**

**OPERATOR PMCS**

**OPERATING PROCEDURES**

**OPERATOR  
TROUBLESHOOTING**

**UNIT PMCS**

**UNIT TROUBLESHOOTING**

**UNIT MAINTENANCE  
PROCEDURES**

**DIRECT SUPPORT  
TROUBLESHOOTING**

**DIRECT SUPPORT  
MAINTENANCE PROCEDURES**

**REPAIR PARTS AND  
SPECIAL TOOLS LIST**

**SUBJECT INDEX**

**WARNING**

Personnel handling solid or liquid pesticides shall use appropriate personal protective equipment consisting of respirators, coveralls, rubber gloves, goggles, etc., as required by type of pesticide used and in accordance with manufacturer's label directions. Avoid direct contact with pesticide. Observe all warnings on label. Handle pesticide in well-ventilated area. Failure to do so could result in personal injury.

**WARNING**

Helicopter shall approach PDU only after pesticide loading is completed and filler openings are secured. Loading pesticide with helicopter hovering will cause pesticide to splash and could result in personal injury.

**WARNING**

Gasoline vapor is highly flammable. Do not fill gas tank while engine is running. Refuel only in a well-ventilated area. Serious personal injury could result if fuel ignites.

**WARNING**

Never use gasoline or other petroleum-base products to clean or preserve hydraulic system parts. If gasoline ignites, serious injury to personnel will occur. Use of gasoline or other petroleum-base products can contaminate hydraulic systems.

**WARNING**

Do not run engine in an enclosed area. Carbon monoxide gases are dangerous and can cause death.

**WARNING**

Ground personnel must be aware of their position in relation to helicopter at all times to prevent personal injury. Ground personnel involved in ground operation of PDU and/or helicopter shall wear protective head gear for ears and eyes to prevent personal injury.

**WARNING**

When lifting heavy parts, always use chain hoist, jack, or other aid. Make certain load limit of lifting device exceeds weight being lifted. Position and rig lifting device before disconnecting part for removal. Failure to do so could result in personal injury.

**WARNING**

Battery electrolyte is an acid, and is highly corrosive. Wear rubber gloves, face shield, and apron. Do not spill on clothing, skin, or PDU. Wash exposed areas with water. Seek medical assistance. Failure to do so could result in personal injury.

**WARNING**

Death or serious injury could result by repeated and/or prolonged breathing and/or skin contact of drycleaning solvent (P-D-680). Use in a well-ventilated area. Do not use near open flame or in excessive heat. The flash point of this solvent is 100°F-183°F (38°C-59°C).

**WARNING**

Cleaning solvents may be toxic to skin, eyes, and respiratory tract. Skin and eye protection is required. Avoid repeated or prolonged contact. Good general ventilation is normally adequate.

**WARNING**

Never use gasoline to clean parts. Gasoline is highly flammable. Serious personal injury could result if fuel ignites.

**WARNING**

Compressed air used for cleaning and drying purposes shall not exceed 30 psi. Use only with effective chip guarding and personal protective equipment (goggles/shield, gloves, etc.). Flying debris could cause personal injury.

**WARNING**

Do not use gasoline or low flashpoint solvent for cleaning. Both are flammable and explosive under certain conditions. Serious personal injury could result if fuel ignites.

**WARNING**

Gasoline is flammable. Do not work on fuel system in presence of sparks and open flame. Serious personal injury could result if fuel ignites.

**WARNING**

Make sure muffler and engine are cooled down before attempting assembly, disassembly, or adjustments. Hot muffler and engine components can cause burns.

**WARNING**

All electrical switches must be OFF before disconnecting or connecting battery cables. Shorting or arcing could cause serious burns.

**WARNING**

Make sure all liquid has been removed from bucket before removing pump and crosstube assembly from bucket. Do not allow liquid to contact skin or eyes. Wear protective clothing. Failure to do so could result in personal injury.

**WARNING**

Assembled PDU is very heavy. Use suitable lifting device and clear area. Do not allow personnel to stand under or near raised unit to prevent personal injury.

**WARNING**

A hovering helicopter (in the air) will create static electricity which exposes personnel to an electrical shock hazard. To avoid electrical shock during the electrical hookup, the groundperson should hold the insulated wires and tap the metal connectors together. This will discharge the static electricity. Alternative methods are the use of a grounding rod and chain, a discharge wand, or touching the helicopter down just before hookup.

**WARNING**

Ensure that hook keeper snaps into locked position or PDU could fall during flight, pulling hand control assembly out of operator's hand. Injury to personnel could result.

**WARNING**

Minimum forward speed of 25 knots is required to stabilize PDU in flight. Below 25 knots, PDU may rotate due to rotor wash. This increases risk of control cord separation at pull-away connector due to possible wrapping of control cord around lifting strap of PDU frame. Maximum speed of helicopter with PDU attached shall not exceed 90 knots (103.5 mph) at altitude of 50-100 ft. Failure to comply may result in injury to personnel or damage to equipment.

**WARNING**

Operator should be aware that foreign objects in slinger can cause injury when system is activated.

**WARNING**

Make sure hand control safety cable hook is fastened to a secure point inside helicopter (e.g., tie down ring). Failure to do so could result in injury or death to personnel.

**WARNING**

Failure to disconnect battery can result in personal injury or damage to equipment.

**RECOMMENDATION TO HELICOPTER PILOT**

The pilot must be briefed not to arm the external cargo electrical release switch. A second switch, the cargo release off arm switch located on the miscellaneous panel, which arms the external cargo electrical release switch, should be monitored by the co-pilot during spray operations. If an emergency situation occurs, the external cargo electrical release switch should be armed or the PDU could be jettisoned using the external cargo mechanical release.

CHANGE

HEADQUARTERS  
DEPARTMENT OF THE ARMY  
WASHINGTON D.C., 25 SEPTEMBER 1992

NO. 1

**Operator's, Unit, and Direct Support  
Maintenance Manual  
Including Repair Parts and Special Tools Lists**

**PESTICIDE DISPERSAL UNIT,  
MULTICAPABILITY, HELICOPTER SLUNG  
(NSN 3740-01-262-8707)**

Approved for public release; distribution is unlimited

TM 5-3740-218-13&P, DATED 13 November 1991 is changed as follows:

1. Appendix F, Unit and Direct Support Maintenance (Including Depot Maintenance) Repair Parts and Special Tools List (RPSTL), Sections II through IV, have been revised to incorporate 100% National Stock Number assignment. Because entire sections are revised, no change bars/hands are used.

2. Remove and insert pages as indicated below. New or changed text material is indicated by a vertical bar in the margin. An illustration change is indicated by a miniature pointing hand.

Remove pages

i through iii/(iv blank)  
F-1

Insert pages

i through iii/(iv blank)  
F-1 through F-75/(F-76 blank)

3. Retain this sheet in front of manual for reference purposes.

**By Order of the Secretary of the Army:**

GORDON R. SULLIVAN  
*General, United States Army*  
*Chief of Staff*

Official:

MILTON H. HAMILTON  
*Administrative Assistant to the*  
*Secretary of the Army*  
02774

DISTRIBUTION:

To be distributed in accordance with DA Form 12-25-E, block no. 5406, requirements for TM 5-3740-218-13&P.

TECHNICAL MANUAL  
 No. 5-3740-2118-13&P

HEADQUARTERS  
 DEPARTMENT OF THE ARMY  
 WASHINGTON, D.C., 13 November 1991

**OPERATOR'S, UNIT, AND DIRECT SUPPORT MAINTENANCE MANUAL  
 INCLUDING REPAIR PARTS AND SPECIAL TOOLS LIST  
 FOR  
 PESTICIDE DISPERSAL UNIT, MULTICAPABILITY, HELICOPTER SLUNG  
 (PDU)  
 (NSN 3240-01-262-8707)**

**REPORTING ERRORS AND RECOMMENDING IMPROVEMENTS**

You can help improve this manual. If you find any mistakes or if you know of a way to improve the procedures, please let us know. Mail your letter, DA Form 2028 (Recommended Changes to Publications and Blank Forms) or DA Form 2028-2 located in the back of this manual, direct to: Commander, U.S. Army Troop Support Command, ATTN: AMSTR-MMTS, 4300 Goodfellow Blvd., St. Louis, MO 63120-1798. A reply will be furnished to you.

**Approved for public release; distribution is unlimited.**

**Page**

<b>CHAPTER 1</b>	<b>INTRODUCTION</b>	
Section I	General Information .....	1-1
II	Equipment Description and Data .....	1-3
III	Technical Principles of Operation .....	1-9
IV	General Cleaning, Inspection, and Maintenance Instructions .....	1-10
<b>CHAPTER 2</b>	<b>OPERATING INSTRUCTIONS</b>	
Section I	Description and Use of Operator's Controls and Indicators .....	2-1
II	Operator Preventive Maintenance Checks and Services (PMCS) .....	2-7
III	Operation Under Usual Conditions .....	2-15
IV	Operation Under Unusual Conditions .....	2-54
<b>CHAPTER 3</b>	<b>OPERATOR MAINTENANCE INSTRUCTIONS</b>	
Section I	Lubrication .....	3-1
II	Troubleshooting .....	3-1

<b>CHAPTER 4</b>	<b>UNIT MAINTENANCE INSTRUCTIONS</b>		
Section I	Repair Parts, Special Tools; Test, Measurement, and Diagnostic Equipment (TMDE); and Support Equipment.....	4-2	
II	Service Upon Receipt .....	4-2	
III	Unit Preventive Maintenance Checks and Services (PMCS).....	4-3	
IV	Troubleshooting .....	4-9	
V	Unit Maintenance Procedures.....	4-17	
VI	Preparation for Storage or Shipment .....	4-161	
<b>CHAPTER 5</b>	<b>DIRECT SUPPORT MAINTENANCE INSTRUCTIONS</b>		
Section I	Repair Parts, Special Tools; Test, Measurement, and Diagnostic Equipment (TMDE); and Support Equipment.....	5-1	
II	Service Upon Receipt .....	5-2	
III	Troubleshooting .....	5-2	
IV	Direct Support Maintenance Procedures.....	5-8	
APPENDIX A	REFERENCES .....	A-1	
APPENDIX B	MAINTENANCE ALLOCATION CHART.....	B-1	
APPENDIX C	COMPONENTS OF END ITEM AND BASIC ISSUE ITEMS LISTS .....	C-1	
APPENDIX D	ADDITIONAL AUTHORIZATION LIST .....	D-1	
APPENDIX E	EXPENDABLE SUPPLIES AND MATERIALS LIST .....	E-1	
APPENDIX F	REPAIR PARTS AND SPECIAL TOOLS LIST (RPSTL).....	F-1	
Section I	INTRODUCTION .....	F-1	
II	REPAIR PARTS LIST		
Group 01	Pesticide Dispersal Unit		
	Pesticide Dispersal Unit.....	F-8	F-1
	Bucket Assembly .....	F-10	F-2
	Engine and Pump Assembly.....	F-12	F-3
	Key Switchbox Assembly.....	F-14	F-4
	Carburetor Assembly .....	F-16	F-5
	Air Cleaner.....	F-18	F-6
	Muffler Assembly .....	F-20	F-7
	Spark Plug .....	F-22	F-8
	Oil Fill and Drain Assembly .....	F-24	F-9
	Starter Motor.....	F-26	F-10
	Hydraulic Pump Assembly .....	F-28	F-11
	Gas Tank Assembly.....	F-30	F-12
	Battery/Hydraulic Assembly .....	F-33	F-13
	Hydraulic Reservoir and Primer Manifold Assembly.....	F-36	F-14
	Hand Control Assembly .....	F-38	F-15
Group 02	Liquid Dispersal System		
	Pump and Crosstube Assembly.....	F-41	F-16



		PAGE	ILLUS/ FIGURE
	Hydraulic Motor and Pump Assembly.....	F-44	F-17
	Spray System Control.....	F-46	F-18
	Low Volume Boom Assembly.....	F-48	F-19
	Low Volume Nozzle Assembly.....	F-50	F-20
	Ultra-Low Volume Boom Assembly.....	F-52	F-21
	Rotary Atomizer.....	F-54	F-22
Group 03	Solid Dispersal System		
	Dry System Hydraulic Installation.....	F-56	F-23
	Dry System Slinger/Hopper Assembly.....	F-58	F-24
	Pump and Slinger Assembly.....	F-60	F-25
	Dry System Hopper Assembly.....	F-62	F-26
Group 04	Dolly Assembly		
	Dolly Assembly.....	F-64	F-27
III	SPECIAL TOOLS (Not Applicable).....	F-66	
IV	CROSS REFERENCE INDEXES.....	F-67	
	National Stock Number Index.....	F-67	
	Part Number Index.....	F-68	
	Figure and Item Number Index.....	F-72	
APPENDIX G	NOZZLE SELECTION AND SYSTEM CALIBRATION.....	G-1	
APPENDIX H	TORQUE LIMITS.....	H-1	
	GLOSSARY.....	Glossary-1	
	SUBJECT INDEX.....	Index-1	

**HOW TO USE THIS MANUAL**

This manual has an edge index that will help you find specific information in a hurry. Simply spread the pages on the right edge of the manual until the printed blocks can be seen. Open the manual where the block on the edge of the page lines up with your selected topic printed in the front cover block.

Refer to Appendix F to determine part numbers and ordering information on replaceable parts.

**CHAPTER 1  
INTRODUCTION**

	<b>Para</b>	<b>Page</b>
Consolidated Index of Army Publications and Blank Forms .....	1-2	1-1
Destruction of Army Materiel to Prevent Enemy Use .....	1-4	1-2
Equipment Characteristics, Capabilities, and Features .....	1-9	1-3
Equipment Configuration.....	1-12	1-7
Equipment Data .....	1-11	1-5
Functional Description.....	1-14	1-9
General Assembly Instructions .....	1-20	1-14
General Cleaning Instructions .....	1-15	1-10
General Disassembly Instructions .....	1-19	1-13
General Inspection Instructions .....	1-16	1-11
General Removal Instructions .....	1-17	1-13
General Repair Instructions.....	1-18	1-13
Location and Description of Major Components.....	1-10	1-3
Maintenance Forms, Records, and Reports.....	1-3	1-2
Nomenclature Cross-Reference List .....	1-6	1-2
Preparation for Storage or Shipment.. ..	1-5	1-2
Reporting Equipment Improvement Recommendations (EIRs) .....	1-7	1-2
Safety, Care, and Handling .....	1-13	1-8
Scope .....	1-1	1-1
Warranty Information .....	1-8	1-2

**Section I. GENERAL INFORMATION**

**1-1. SCOPE**

This manual provides description, operation, and maintenance information, as well as a Repair Parts List, for the Pesticide Dispersal Unit, MULTICAPABILITY, Helicopter Slung (PDU). Maintenance procedures include instructions for removal, disassembly, cleaning, inspection, testing, troubleshooting, repair or replacement, and installation of components as they apply to operator, unit, and direct support maintenance personnel.

This chapter describes the three configurations of the PDU and identifies the differences between them, identifies major systems and components, provides detailed operating principles, and discusses various management and support functions associated with the PDU.

**1-2. CONSOLIDATED INDEX OF ARMY PUBLICATIONS AND BLANK FORMS**

Refer to the latest issue of DA Pam 25-30 to determine whether there are new editions, changes, or additional publications pertaining to the PDU.

**1-3. MAINTENANCE FORMS, RECORDS, AND REPORTS**

a. Reports of Maintenance and Unsatisfactory Equipment. Department of the Army forms and procedures used for equipment maintenance will be those prescribed by DA Pam 738-750, The Army Maintenance Management System (TAMMS).

b. Report of Packaging and Handling Deficiencies. Fill out and forward Report of Discrepancy (ROD) (SF 364) as prescribed in AR 735-1 1-2.

c. Transportation Discrepancy Report (TDR) (SF 361). Fill out and forward Transportation Discrepancy Report (TDR) (SF 36 1) as prescribed in AR 55-38.

**1-4. DESTRUCTION OF ARMY MATERIEL TO PREVENT ENEMY USE**

Demolition and destruction of the equipment will be under the direction of the Commander and in accordance with TM 750-244-3.

**1-5. PREPARATION FOR STORAGE OR SHIPMENT**

Storage and shipment procedures for the PDU are found in chapter 4, paragraph 4- 57.

**1-6. NOMENCLATURE CROSS-REFERENCE LIST**

This listing identifies approved nomenclature usage that is different from the official nomenclature:

Common Name	Official Nomenclature
PDU .....	Pesticide Dispersal Unit, MULTICAPABILITY, Helicopter Slung

**1-7. REPORTING EQUIPMENT IMPROVEMENT RECOMMENDATIONS (EIRs)**

If your PDU needs improvement, let us know. Send us an EIR. You, the user, are the only one who can tell us what you don't like about the equipment. Put it on an SF 368 (Product Quality Deficiency Report). Mail it to us at: Commander, U.S. Army Troop Support Command, ATTN: AMSTR-MOF, 4300 Goodfellow Blvd., St. Louis, MO 63 120-1798. We'll send you a reply.

**1-8. WARRANTY INFORMATION**

The PDU is warranted by Simplex Manufacturing Co. for 1 year. The warranty starts on the date found in block 23, DA Form 2408-9, in the logbook. Report all defects in material or workmanship to your supervisor who will take appropriate action through your unit maintenance shop.

## Section II. EQUIPMENT DESCRIPTION AND DATA

### 1-9. EQUIPMENT CHARACTERISTICS, CAPABILITIES, AND FEATURES

The PDU is slung from the bottom of a helicopter and is compatible with any utility helicopter that has a cargo hook. The PDU's self-contained power source is electrically and mechanically independent of the helicopter. The PDU can be jettisoned in an emergency and requires no helicopter modifications. Remote control operation allows dispersal of solid or liquid pesticides from the helicopter operator's compartment. Depending upon equipment configuration, liquid pesticides can be dispersed using the low volume (LV) system for sparse landscape or by using the ultra-low volume (ULV) system when covering dense foliage. The solid dispersal (SD) system uses a slinger assembly to disperse solid-type pesticides. The characteristics, capabilities, and features of the PDU are listed below.

#### a. Characteristics.

- (1) Dispersal of liquid pesticides (LV or ULV systems)
- (2) Dispersal of solid pesticides (SD system)

#### b. Capabilities and Features.

- (1) Hand control for operation from helicopter
- (2) Tail fin provides for stable flight attitude
- (3) Quick disconnect for emergency release (jettison) from helicopter
- (4) Close coupled to helicopter utilizing a single lifting strap
- (5) Totally enclosed SD system
- (6) Self-contained power source independent of helicopter
- (7) Can be used on any helicopter with a cargo hook, without modification

### 1-10. LOCATION AND DESCRIPTION OF MAJOR COMPONENTS

The major components of the PDU are described below. Refer to figure 1-1 for location.

BUCKET ASSEMBLY (1) - Fiberglass hopper that holds solid or liquid pesticide. Support frame provides for mounting of engine, gas tank assembly, pump, and hydraulic reservoir.

HAND CONTROL ASSEMBLY (2) - Allows operator to operate PDU from either inside or outside of helicopter.

HYDRAULIC RESERVOIR (3) - Provides supply of hydraulic fluid for system.

GAS TANK (4) - Provides fuel for engine.

ENGINE (5) - Provides power to drive main hydraulic pump.

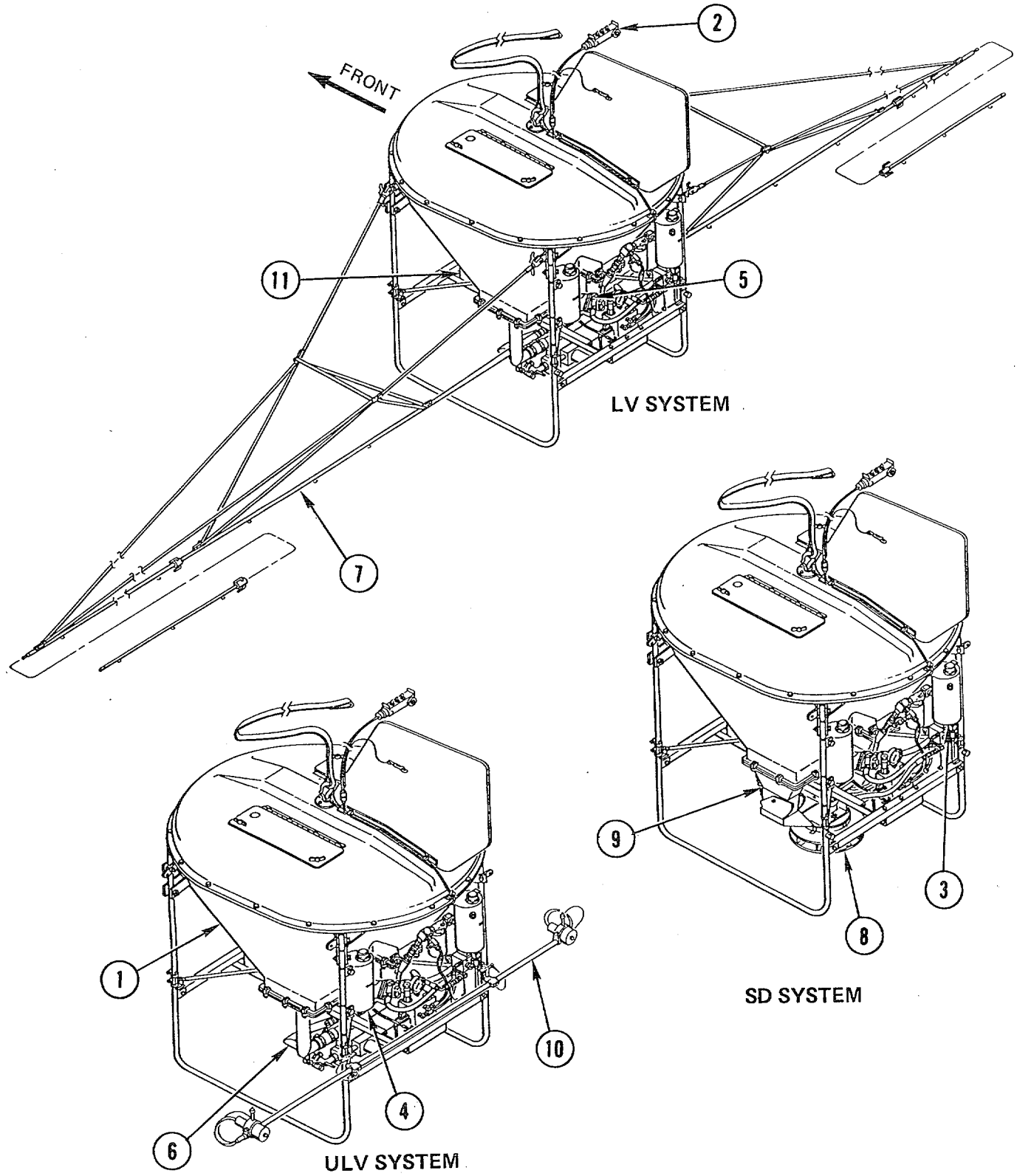

Figure 1-1. PDU Major Components

PUMP AND CROSSTUBE ASSEMBLY (6) - Provides hydraulic pressure for operation of LV and ULV systems.

LV BOOM ASSEMBLY (7) - Provides LV dispersal of liquid pesticides where minimum penetration is acceptable (sparse foliage). Transports liquid pesticide from bucket to nozzles and provides attachment sites for up to 34 nozzles.

SLINGER ASSEMBLY (8) - Provides for dispersal of solid pesticides by rotary action.

LEFT AND RIGHT HOPPER ASSEMBLIES (9) - Controls solid pesticide dispersal through hydraulically actuated gates.

ULV BOOM ASSEMBLY (10) - Provides ULV dispersal of liquid pesticides where maximum penetration is needed (dense foliage). Provides attachment for two hydraulically actuated rotary atomizers.

BATTERY (11) - Provides electrical power to starter.

**1-11. EQUIPMENT DATA**

WEIGHT (empty)

SD System.....	310 lb (140.6 kg)
LV System.....	375 lb (170.1 kg)
ULV System.....	345 lb (156.5 kg)

WEIGHT (full)

SD System.....	865-1,500 lb* (392.4-680.4 kg)
LV System.....	1,625 lb* (737.1 kg)
ULV System.....	1,590 lb* (721.2 kg)

BUCKET HEIGHT

Bucket .....	5.1 ft (1.6 m)
Bucket w/Tail Fin .....	6.7 ft (2.0 m)

BUCKET WIDTH ..... 3.8 ft (1.2 m)

BUCKET LENGTH..... 6.2 ft (1.9 m)

BOOM SPAN

LV System.....	33 ft 9 in. (10.3 m)
ULV System.....	10 ft (3.0 m)

NOZZLES

LV System.....	34 maximum
ULV System.....	2 maximum

\* Depends on density of material being dispersed.

EFFECTIVE SWATH\*\*

SD System.....	200 ft (61.0 m)
LV System .....	200-300 ft (61.0-91.4 m)
ULV System.....	150-300 ft (45.7-91.4 m)

CAPACITY

SD System.....	20 cu ft (0.6 cu m)
LV System .....	150 gal (567.8 l)
ULV System.....	150 gal (567.8 l)

FLOW RATE

SD System.....	0.2-5.0 cu ft/min (39.3-983.2 cu cm/min)
.....	5-600 lb/min* (2.3-272.2 kg/min)
LV System .....	6-210 gpm (22.7-795.0 lpm)
ULV System.....	1-8 gpm (3.8-30.3 lpm)

MAXIMUM OPERATING SPEED ..... 90 knots (164.6 km/hr)

OPERATING ALTITUDE..... 50-100 ft (15.2-30.5 m)

HYDRAULIC RESERVOIR

Capacity .....	6 qt (5.7 l)
Fluid Type.....	Shell-Tell us 68 or equivalent

ENGINE

Type.....	Honda, Model GCS-340 (modified)
4-stroke, overhead valve, single cylinder inclined 25 degrees, forced-air cooled	
Dimensions (L x W x H).....	16.25 x 17.7 x 17.1 in. (415 x 450 x 435 mm)
Horsepower.....	11 hp at 3600 rpm
Weight (dry).....	68.34 lb (31 kg)
Weight (operating) .....	81.57 lb (37 kg)
Displacement.....	20.6 cu in. (337 cc)
Bore x Stroke.....	3.23 x 2.52 in. (82 x 64 mm)
Compression Ratio .....	8.0:1
Maximum Torque.....	17.3 lb-ft/2500 rpm (240 kg-cm/2500 rpm)
Maximum Speed.....	3600 rpm

\* Depends on density of material being dispersed.

\*\* Baseline estimate - 100 ft (30.5 m) above ground level, at 50 knots (91.4 km/hr), with negligible wind.

Idle Speed ..... 1400 +150 rpm  
 Starter..... Electrical, 12 volt

**FUEL TANK**

Capacity ..... 1.72 gal (6.5 l)  
 Maximum Operating Time ..... 1-1/2 hours under full load  
 Fuel Type ..... Regular (lead-free) gasoline  
 Fuel Consumption..... 0.51 lb/HPh (230 g/HPh)

**OIL RESERVOIR**

Oil Type ..... SAE 10W-40  
 Capacity ..... 1.16 qt (1.1 l)

**ELECTRICAL POWER REQUIREMENT..... 12 VDC battery**

**BATTERY**

Group Size..... 24 RUD  
 Type .....24-90 MCR  
 Cranking Performance ..... Deep cycle  
 Reserve Capacity (25 Amps at 800F)..... 150 minutes  
 Dimensions (L x W x H)..... 11-3/16 x 6-5/8 x 9-3/4

**1-12. EQUIPMENT CONFIGURATION**

a. The PDU consists of a basic system with accessories that can be set up in three system configurations (LV, ULV, and SD) for dispersal of liquid or solid-type pesticides. The basic system includes the following:

- (1) Bucket assembly
- (2) Hand control
- (3) Hydraulic reservoir and manifold assembly
- (4) Gas tank
- (5) Battery/hydraulic assembly

b. The LV system consists of the basic system with the LV boom assembly and the pump and crosstube assembly. The ULV system consists of the basic system with the ULV boom assembly and the pump and crosstube assembly. The SD system consists of the basic system with the slinger assembly and the left and right hopper assemblies.



**1-13. SAFETY, CARE, AND HANDLING**

The following safety precautions should be observed when operating the PDU. Failure to observe these safety precautions may result in serious injury to personnel or damage to equipment.

- a. Personnel handling solid or liquid pesticides shall use appropriate personal protective equipment consisting of respirators, coveralls, rubber gloves, goggles, etc., as required by type of pesticide used and in accordance with manufacturer's label directions. Observe all warnings on label. Handle pesticide in well-ventilated area.
- b. Handle pesticide in a well-ventilated area only.
- c. Gasoline vapor is highly flammable. Do not fill gas tank while engine is running. Refuel only in a well-ventilated area.
- d. Do not run engine in an enclosed area.
- e. Battery electrolyte is an acid, and is highly corrosive. Wear rubber gloves, face shield, and apron. Do not spill on clothing, skin, or PDU.
- f. Ear protection should be worn by ground personnel during ground operation of PDU.
- g. Helicopter shall not exceed airspeed of 90 knots.
- h. Helicopter shall approach PDU only after pesticide loading is completed and filler openings are secured.
- i. Pull-apart connector in control cord must always be used and not be defeated by any means.
- j. Do not operate pump when hydraulic reservoir is empty. Add approximately five quarts hydraulic fluid to hydraulic reservoir to prevent pump seal damage.
- k. During ground tests, do not exceed 30-minute operating time.
- l. Check that gas, oil, hydraulic fluid, and battery electrolyte levels are at operating minimums prior to operation.
- m. When not in use, key switch on side of engine must be OFF to prevent battery drain.

### Section III. TECHNICAL PRINCIPLES OF OPERATION

#### 1-14. FUNCTIONAL DESCRIPTION

- a. The PDU is used in three configurations: LV liquid spray, ULV liquid spray, and SD solid particle. During operation, the PDU is suspended from a helicopter by a lifting strap. All configurations consist of a bucket containing the pesticide, a gasoline-powered engine, and a hydraulic pump. In the LV configuration, liquid pesticide is pumped by a hydraulic motor-driven centrifugal pump from the bucket to boom spray nozzles. In the ULV configuration, liquid pesticide is pumped by the centrifugal pump from the bucket to boom rotary atomizers. The rotary atomizers are hydraulically driven. In the SD configuration, solid-particle pesticide drops from the bucket to the slinger, where it is dispersed by hydraulic motor-driven vanes.
- b. The hand control (figure 1-2) operates the PDU from inside the helicopter. When the POWER switch is in the ON position, battery power is applied to the engine. When the ENGINE START switch is positioned to START and held, the starter is engaged to start the engine. After the engine is running, the ENGINE START switch should be released and the switch will spring to the run position. Pressing the DISPERSAL pushbutton will release the pesticide.

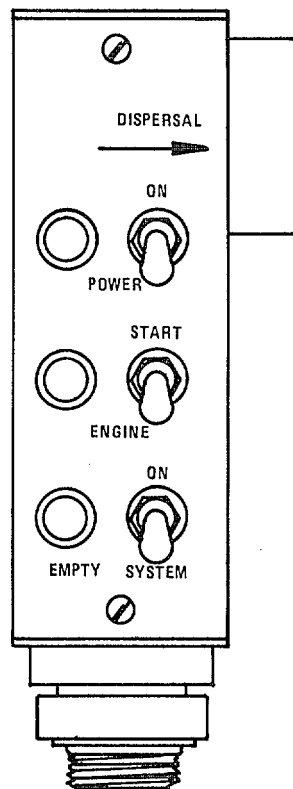

Figure 1-2. Hand Control Assembly

## Section IV. GENERAL CLEANING, INSPECTION, AND MAINTENANCE INSTRUCTIONS

### 1-15. GENERAL CLEANING INSTRUCTIONS

#### WARNING

Cleaning solvents may be toxic to skin, eyes, and respiratory tract. Skin and eye protection is required. Avoid repeated or prolonged contact. Good general ventilation is normally adequate.

Death or serious injury could result by repeated and/or prolonged breathing and/or skin contact of drycleaning solvent P-D-680. Use in a well-ventilated area. Do not use near open flame or in excessive heat. The flash point of this solvent is 100°F-138°F (38°C-.59°C).

Never use gasoline to clean parts. Gasoline is highly flammable. Serious personal injury could result if fuel ignites.

#### CAUTION

Petroleum solvents may damage parts that are in contact with hydraulic fluids.

Do not clean tires, lubricant seals, rubber hoses, or electrical components with solvent mixture.

Do not use scrapers, wire brushes, abrasive wheels, or compounds in cleaning parts, unless called for in detailed instructions. These procedures may weaken a highly stressed part.

- a. **Cleaning Solvents.** Use only approved cleaning solvents to clean parts. Drycleaning solvent P-D-680 (item 59, Appendix E) is commonly used. Always work in well-ventilated area.

---

**WARNING**

---

Compressed air used for cleaning and drying purposes shall not exceed 30 psi. Use only with effective chip guarding and personal protective equipment (goggles/shield, gloves, etc.). Flying debris could cause personal injury.

**CAUTION**

Do not use scrapers, wire brushes, abrasive wheels, or compounds in cleaning parts, unless called for in detailed instructions. These procedures may weaken a highly stressed part.

b. **Removing Deposits.** After soaking parts in solvent, wash away deposits by flushing or spraying. Where necessary, brush with soft-bristle brush moistened in solvent. Use compressed air to dry all parts, except bearings. Bearings must be allowed to air dry.

c. **Bearings.** When cleaning bearings, place them in basket and suspend in container of drycleaning solvent. If needed, use brush to remove caked grease, chips, etc. Avoid rotating bearing before solid particles are removed to prevent damaging races and balls. When bearings have been cleaned, coat lightly with lubricating oil (item 38, Appendix E) to remove solvent.

**1-16. GENERAL INSPECTION INSTRUCTIONS**

Inspection consists of checking for defects such as distortion, wear, cracks, and pitting. Parts under heavy load or pressure must be inspected more thoroughly. Clean all parts before inspection.

a. **Sealing Surfaces.** Inspect all surfaces in contact with gaskets, packings, or seals. Make sure there are no nicks, burrs, or scratches. If any defect is found, remove or repair it as outlined in General Repair Instructions (para 1-18).

b. **Bearings.** Check bearings for rusted or pitted balls, races, or separators. Check balls and races for brinnelling, abrasion, and serious discoloration. Following are causes for bearing rejection:

- (1) Cuts or grooves parallel to ball or roller rotation.
- (2) Fatigue pits (not minor machine marks or scratches).
- (3) Cracks.

c. **Drain Plugs.** When removing drain plugs, inspect sediment adhering to plug. Buildup of grit and/or fine metal particles may indicate part failure. A few fine particles are normal.

---

**WARNING**

---

Death or serious injury could result by repeated and/or prolonged breathing and/or skin contact of drycleaning solvent P-D-680. Use in a well-ventilated area. Do not use near open flame or in excessive heat. The flash point of this solvent is 1000F-138°F (38°C-59°C).

d. **Electrical Parts.** Electrical parts that use insulating materials should not be soaked or sprayed with cleaning solutions. Clean with clean, lint-free cloth (item 4, Appendix E) moistened with drycleaning solvent P-D-680 (item 59, Appendix E).

**CAUTION**

Do not use soap or alkalies for cleaning tank interiors.

e. **Hydraulic and Fuel Tanks.** Pay special attention to all Warnings and Cautions when working on fuel tank. Tanks should be flushed, using spray gun and drycleaning solvent P-D-680 (item 59, Appendix E).

f. **Battery.** Exterior surfaces of electrical system and battery should be cleaned with weak solution of baking soda (item 57, Appendix E) and water. Apply solution with bristle brush to remove any corrosion.

---

**WARNING**

---

Death or serious injury could result by repeated and/or prolonged breathing and/or skin contact of drycleaning solvent P-D-680. Use in a well-ventilated area. Do not use near open flame or in excessive heat. The flash point of this solvent is 100°F-138°F (38°C-59°C).

Never use gasoline or other petroleum-base products to clean or preserve hydraulic system parts. If gasoline ignites, serious injury to personnel will occur. Use of gasoline or other petroleum-base products can contaminate hydraulic systems.

g. **Hydraulic System.** When cleaning hydraulic system parts, use drycleaning solvent P-D-680 (item 59, Appendix E). Clean and dry parts thoroughly to make sure no residue remains. If coating of preservative is required before assembly, apply light film of preservative oil (item 39, Appendix E).

h. **Parts Protection.** To prevent moisture and dirt from entering open housings, lines, and other openings, apply protective caps and plugs as soon as possible after disassembly. Wrap all removed parts in clean paper or dip parts in preservative oil (item 39, Appendix E).

i. **Tubing and Hose.** Check all hose surfaces for broken or frayed fabric. Check for breaks caused by sharp kinks or rubbing against other parts. Inspect fitting threads for damage. Replace any part found defective. Check for leaks.

j. **Electrical Parts.** Inspect all wiring harnesses for chafed or burned insulation. Inspect all terminal connectors for loose connections and broken parts.

### 1-17. GENERAL REMOVAL INSTRUCTIONS

a. **Work Required.** Remove only those parts needing repair or replacement. Do not disassemble component any further than needed.

b. **Preparation.** Before removing any part of electrical or hydraulic system, make certain system is not energized or pressurized. Disconnect battery cables. Make sure all controls are off before starting any removal procedure.

c. **Lifting.** Always use chain hoist, jack, or other aid when lifting heavy parts. Make certain load limit of lifting device exceeds weight being lifted. Position and rig lifting device before disconnecting part for removal.

d. **Identification.** Tag or mark all similar parts, such as electrical leads, before disconnecting and removing. This will make proper assembly easier. Be sure to identify mating ends of electric and hydraulic lines as they are disconnected.

### 1-18. GENERAL REPAIR INSTRUCTIONS

a. **Electrical Parts.** Replace all broken, worn, or burned electrical wiring. Wires with several broken strands must be replaced. Broken strands will increase resistance of wire and impair efficiency of electrical components, especially ignition system.

b. **Hoses.** Replace all broken, frayed, crimped, or soft flexible lines and hoses. Replace stripped or damaged fittings. Replace entire flexible hose if fittings are damaged. Make sure hose clamps do not crimp hoses.

c. **Fasteners.** Replace any bolt, screw, nut, or fitting with damaged threads. Inspect tapped holes for thread damage. If cross-threading or galling is evident, retap holes for next oversize screw or stud. When retapping will weaken part, or when cost of part makes retapping impractical, replace damaged part. Chasing threads with proper size tap or die may often be enough.

### 1-19. GENERAL DISASSEMBLY INSTRUCTIONS

a. **Cleanliness.** Work area must be kept as clean as possible to prevent contamination of internal parts. This is especially true for valves, cylinders, pumps, and motors. Dirt or grit will damage machined surfaces and will result in leakage or premature motor failure.

b. **Mandatory Replacement Parts.** All gaskets, O-rings, packings, and seals removed must be discarded and replaced with new parts. These items are usually damaged during removal. All lockwire, cotter pins, and like items must be discarded.

c. **Removing Seals.** When removing gaskets, packings, or seals, do not use metal tool that will scratch surfaces next to these items.

d. **Disassembly.** Before disassembly of any item, study illustration carefully. Note relationship of internal parts. Knowing details of component will speed up disassembly and assembly and help avoid mistakes.

## 1-20. GENERAL ASSEMBLY INSTRUCTIONS

- a. **Preparation.** Remove grease from new parts before installation.
- b. **Gaskets.** To provide added sealing for gasket, coat both sides with sealant. Remove all traces of previous gasket and sealant before installing new gasket.
- c. **Safety Wire.** Remove safety wire from all new parts before installing on equipment.
- d. **Bearings and Shafts.** During assembly of shafts and bearings in housings, first mount bearing on shaft. Then install assembly by applying force to shaft. When mounting bearings on shafts, always apply force to inner races of bearing.
- e. **Bearing Lubrication.** Lubricate bearings before reassembly with type of lubricant normally used in related housing or container. This will provide lubrication during first run-in until lubricant from system can reach bearings.

**CHAPTER 2  
OPERATING INSTRUCTIONS**

	<b>Para</b>	<b>Page</b>
Attaching PDU to Helicopter.....	2-11	2-37
Emergency Operation .....	2-21	2-55
Flying PDU to Mission Location.....	2-12	2-44
General .....	2-4	2-7
Hand Control Switches and Indicators .....	2-1	2-1
Hydraulic System Controls and Indicators .....	2-2	2-4
Initial Adjustments and Tests.....	2-10	2-26
Landing PDU.....	2-14	2-46
Leakage Definitions.....	2-6	2-8
Operation in Dusty or Sandy Areas .....	2-18	2-54
Operation in Extreme Heat.....	2-17	2-54
Operation in Salt Water Areas.....	2-20	2-54
Operation Under Rainy or Humid Conditions .....	2-19	2-54
PDU Operation .....	2-13	2-45
PMCS Table .....	2-7	2-8
Post-Mission Servicing .....	2-15	2-47
Power-On Controls .....	2-3	2-6
Preparation for Movement.....	2-16	2-48
Preparation for Use .....	2-9	2-15
Special Instructions .....	2-5	2-7
Unpacking.....	2-8	2-15

**Section I. DESCRIPTION AND USE OF OPERATOR'S CONTROLS  
AND INDICATORS**

**2-1. HAND CONTROL SWITCHES AND INDICATORS**

Figure 2-1 shows the operator's hand-held control unit for the Pesticide Dispersal Unit, MULTICAPABILITY, Helicopter Slung (PDU). All switches and indicators are identified and keyed to the function descriptions provided in table 2-1.



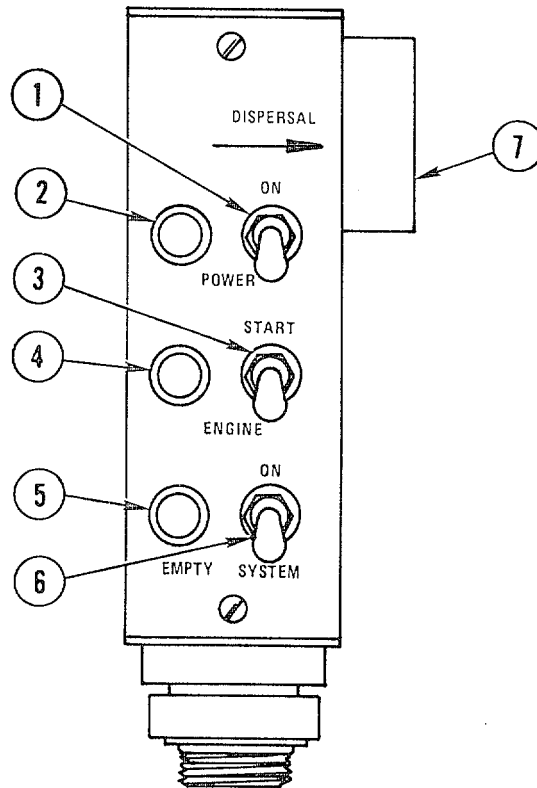

Figure 2-1. Hand Control Switches and Indicators

Table 2-1. Hand Control Switches and Indicators

Key	Control Or Indicator	Function
1	POWER Switch	ON connects battery power to engine. OFF disconnects power. This switch should be used for emergency power-off.
2	POWER Indicator	When lit (green), indicates electrical power is connected to engine. When not lit, electrical power is not reaching engine.
3	ENGINE START Switch	When set to START, starter is engaged. When released, starter is disengaged.
4	ENGINE Indicator	When lit (green), indicates engine is running. When not lit, engine is not running.
5	EMPTY Indicator	When lit (amber), pesticide bucket is empty. When not lit, bucket contains pesticide.

Table 2-1. Hand Control Switches and Indicators (Cont)

Key	Control Or Indicator	Function
6	SYSTEM ON/OFF	When ON in LV configuration, hydraulic pressure is applied to pesticide pump; in ULV configuration, hydraulic pressure is applied to pesticide pump and rotary atomizers; in SD configuration, hydraulic pressure is applied to slinger. When OFF, hydraulic pressure is removed.
7	DISPERSAL Pushbutton	When pressed in LV or ULV configuration, dispersal valve is activated (liquid pesticide is dispersed). When pressed in SD configuration, hydraulic gates are actuated (solid pesticide is dispersed). Disperses pesticide in bucket.

**2-2. HYDRAULIC SYSTEM CONTROLS AND INDICATORS**

Figure 2-2 shows the locations of the hydraulic system controls and gages. The function of each gage and control is described in table 2-2.

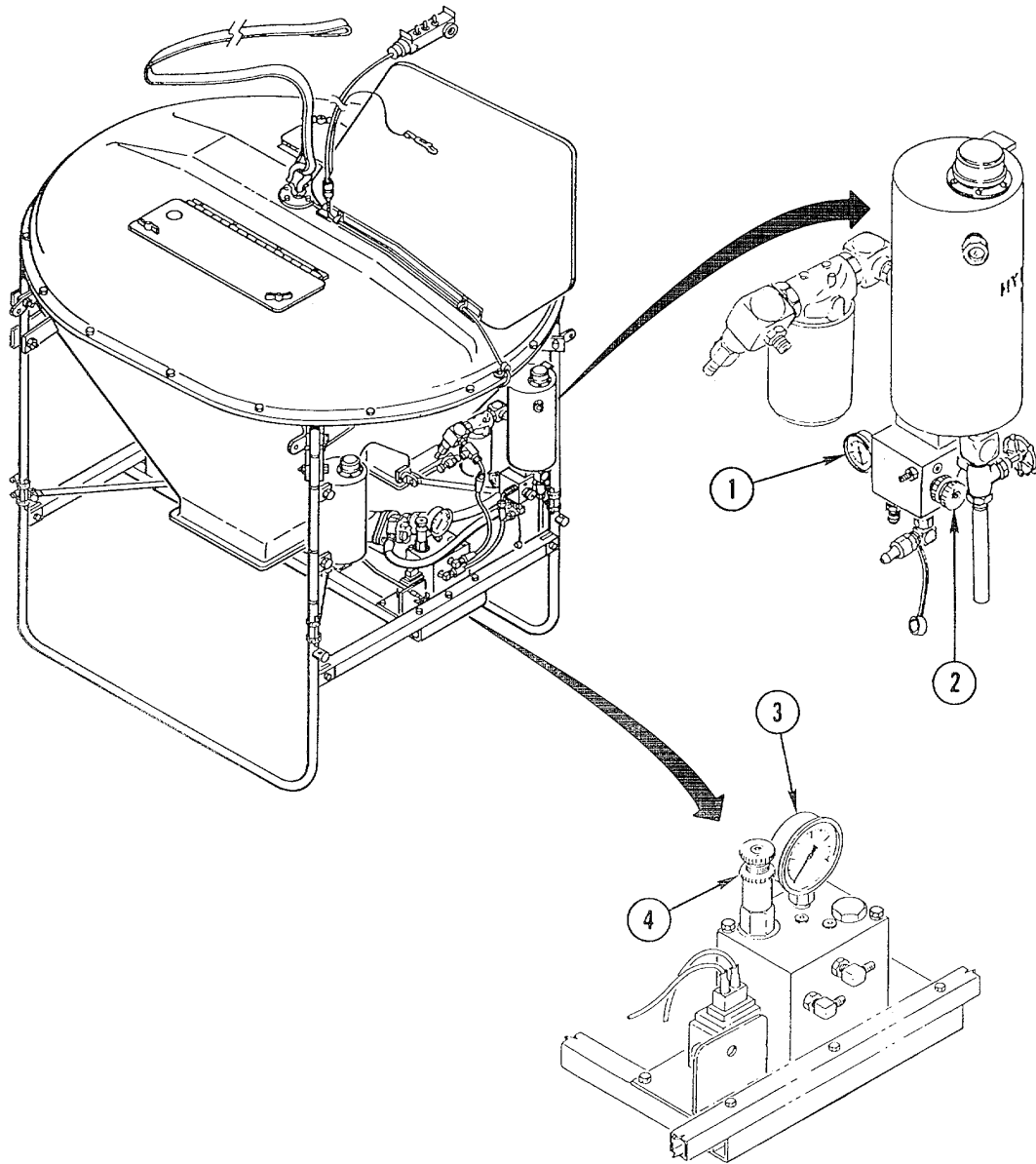

**Figure 2-2. Hydraulic System Gages and Control Knobs**

**Table 2-2. Hydraulic System Gages and Controls**

<b>Key</b>	<b>Gage or Control</b>	<b>Function</b>
1	Hydraulic Pressure Gage (Primary Mainifold)	Shows hydraulic fluid pressure for entire hydraulic system.
2	Hydraulic Pressure Control Knob (Primary Mainifold)	(LV and ULV) Permits adjustment of hydraulic pressure to primary manifold pesticide pump, allowing boom pressure (flow rate of liquid pesticide) to be regulated. Also controls speed of rotary atomizers.
3	Hydraulic Pressure Gage (Secondary Manifold)	Shows hydraulic fluid pressure for dispersal valve in LV and ULV configurations, and for chute gate actuators in SD configuration. This manifold is normally adjusted for 300 psi. If adjusted above 400 psi, damage to hydraulic system could occur.
4	Hydraulic Pressure Control Knob (Secondary Manifold)	Permits adjustment of hydraulic pressure to dispersal valve and chute gate actuators.

**2-3. POWER-ON CONTROLS**

Figure 2-3 shows the locations of the START key switch and throttle control. Table 2-3 explains their functions.

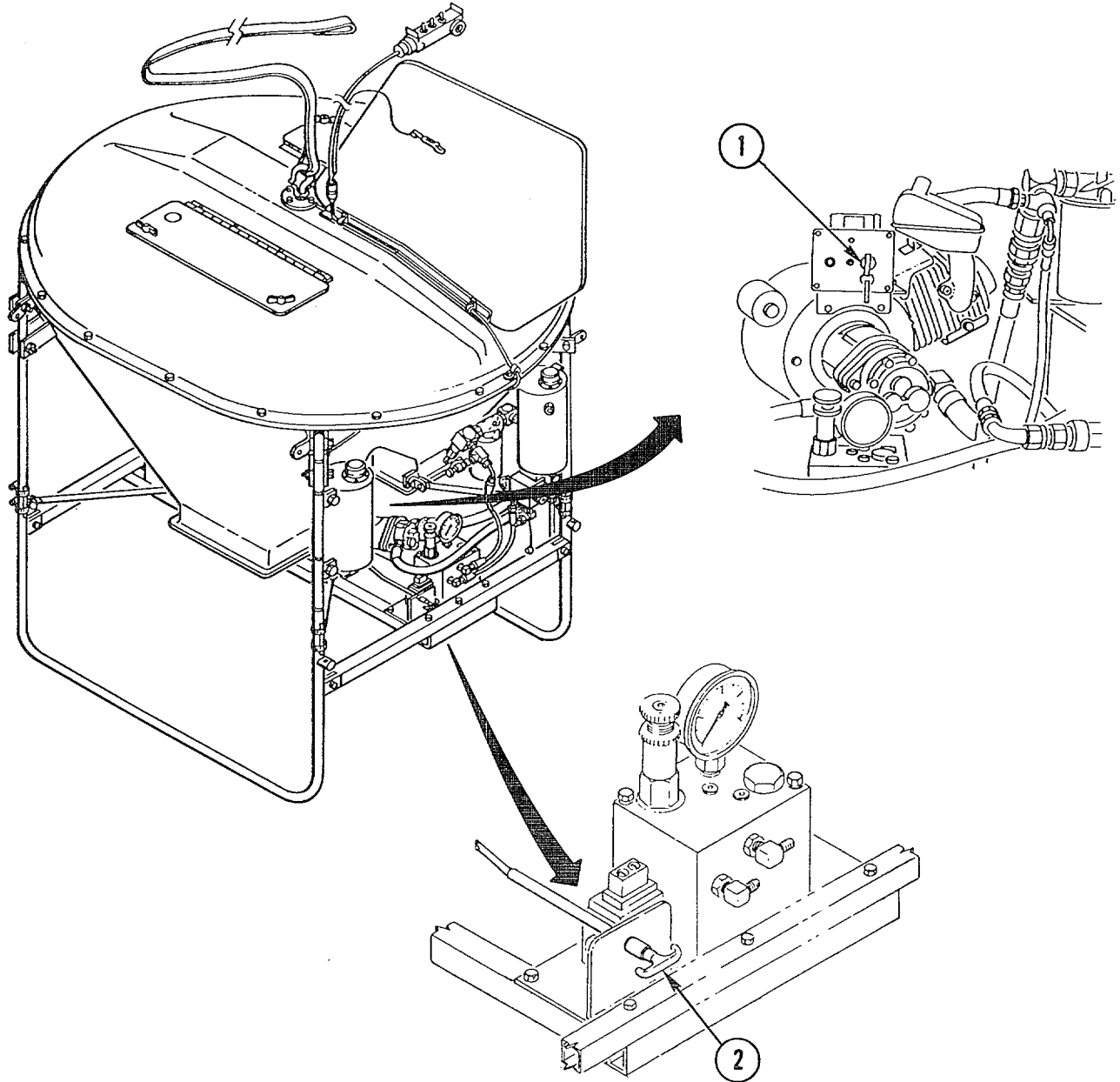

**Figure 2-3. Power-On Controls**

Table 2-3. Power-On Controls

Key	Control	Function
1	START Key Switch	In START position, engine's starter is activated. In ON position, electrical power reaches engine and starts PDU. In OFF position, electrical power is prevented from reaching engine.
2	THROTTLE	Throttle handle must be pressed in to enable cold starting engine. Once engine is warmed up, throttle should be pulled out to enable pesticide dispersal.

## Section II. OPERATOR PREVENTIVE MAINTENANCE CHECKS AND SERVICES (PMCS)

### 2-4. GENERAL

Operator level PMCS of the PDU consists of general inspection, cleaning, and filling fluid tanks as necessary.

- a. **Before You Operate.** Always keep in mind the CAUTIONS and WARNINGS. Perform your before PMCS.
- b. **While You Operate.** Always keep in mind the CAUTIONS and WARNINGS. Perform your during PMCS.
- c. **After You Operate.** Be sure to perform your after PMCS.
- d. **If Your Equipment Fails to Operate.** Troubleshoot with proper equipment. Report any deficiencies using the proper forms. See DA Pam 738-750.

### 2-5. SPECIAL INSTRUCTIONS

#### CAUTION

If minor defects are found while PDU is in service, note and have fixed immediately following mission. If any defect develops while sprayer is running that could damage PDU, stop operation at once and contact appropriate level of maintenance.

Perform the before/during PMCS if the following conditions are applicable:

- a. You are the assigned operator and have not operated the item since the last PMCS.
- b. You are operating the item for the first time.

## 2-6. LEAKAGE DEFINITIONS

Leakage definitions for operator PMCS shall be classified as follows:

### **CAUTION**

You may continue to operate equipment with Class I or Class II leaks; however, check fluid levels frequently. When in doubt, notify your supervisor. Report Class III leaks to your supervisor or unit maintenance immediately.

- a. Class I. Seepage of fluid (as indicated by wetness or discoloration) not great enough to form drops.
- b. Class II. Leakage of fluid great enough to form drops but not enough to cause drops to drip from item being checked/inspected.
- c. Class III. Leakage of fluid great enough to form drops that fall from item being checked/inspected.

## 2-7. PMCS TABLE

PMCS procedures are to be performed as shown in table 2-4. These procedures are designed to protect both the operator and the equipment. Performing them as directed ensures that the PDU is ready for operation at all times. The following paragraphs explain the column headings in table 2-4.

- a. Item No. Column. The numbers appearing in this column are in the order the work should be done. This column shall also be used as a source of item numbers for the TM Number Column on DA Form 2404 (Equipment Inspection and Maintenance Worksheet) for recording results of PMCS.
- b. Interval Column. This column indicates whether PMCS are done before operation (B), during operation (D), or after operation (A).
- c. Item to be Inspected Column. This column identifies the item to be inspected.
- d. Procedure Column. This column contains a brief description of the check or service to be performed and step-by-step procedures.
- e. Equipment is Not Ready/Available If Column. This column identifies the condition that prevents the equipment from being ready for operation.

### **NOTE**

To conduct PMCS on a specific configuration, it may be necessary to remove or install certain components or subassemblies. Refer to appropriate paragraphs in section III of this chapter.

**Table 2-4. Operator Level PMCS**

NOTE: Within designated interval, these checks are to be performed in the order listed.

B-Before

D-During

A-After

ITEM NO.	INTERVAL			Item To Be Inspected	Procedures	EQUIPMENT IS NOT READY/AVAILABLE IF:
	B	D	A			
1	•			Engine Oil Level	<p>Add oil as necessary to bring level to upper limit of oil fill. Use SAE 10W-40 (item 40, Appendix E).</p> <p style="text-align: center;"><b>WARNING</b></p> <p>Gasoline vapor is highly flammable. Do not fill gas tank while engine is running. Refuel only in a well-ventilated area. Serious personal injury could result if fuel ignites.</p>	Oil level low.
2	•			Gas Tank:	<p>Check level; fill if necessary with regular gasoline (item 19, Appendix E). Check fuel filter; remove and clean if necessary.</p> <p style="text-align: center;"><b>NOTE</b></p> <p>Ensure 3/4-in. gate valve is closed before filling hydraulic reservoir.</p>	Level too low to complete mission.
3	•			Hydraulic Reservoir	<p>Check fluid level; fill if necessary with Shell-Tellus 68 or equivalent (item 10, Appendix E).</p>	Level not at sight gage.



**Table 2-4. Operator Level PMCS (Cont)**

NOTE: Within designated interval, these checks are to be performed in the order listed.

B-Before

D-During

A-After

ITEM NO.	INTERVAL			Item To Be Inspected	Procedures	EQUIPMENT IS NOT READY/AVAILABLE IF:
	B	D	A			
					<p><b><u>WARNING</u></b></p> <p>Battery electrolyte is an acid, and is highly corrosive. Wear rubber gloves, face shield, and apron. Do not spill on clothing, skin, or PDU. Wash exposed areas with water. Seek medical assistance. Failure to do so could result in personal injury.</p>	
4	•			Battery	Check terminals for corrosion. Check battery for cracks and leaks. Ensure cables are tight. Check battery box for damage. Refer to unit maintenance.	Terminals corroded or cables loose. Battery cracked or leaking.
5	•			Air Cleaner	Check for cleanliness; clean if dirty.	Clogged or damaged.
					<p><b>NOTE</b></p> <p>Ensure 3/4-in. ball valve is closed before filling bucket.</p>	
6	•			Bucket	Check for cracks. If liquid pesticide will be dispersed, fill with water to 30-gal mark (leave water in bucket for use in other checks).	Leaks exceed Class II.
	•			Doors, Gaskets, and Ports	Check for ease of operation and proper seal.	Cannot be secured.
	•			Fin	Check to see if loose or broken.	Not secured, broken, or missing.
	•			Frame	Check for loose, broken, or missing hardware.	Components loose, broken, or missing.

**Table 2-4. Operator Level PMCS (Cont)**

NOTE: Within designated interval, these checks are to be performed in the order listed.

B-Before

D-During

A-After

ITEM NO.	INTERVAL			Item To Be Inspected	Procedures	EQUIPMENT IS NOT READY/AVAILABLE IF:
	B	D	A			
7	•			Sling Hook Assembly	Check for tightness of hardware inside and outside of bucket. Check hook for ease of swivel action; if swivel action is not smooth, lubricate.	Essential hardware missing.
	•			Wiring Harness	Check wiring harness for cut or torn insulation, frayed or broken wires. Check harness mounting clamps for security.	Insulation or wires damaged.
	•			Sight Gages	Check sight gages for damage and security.	Damaged or missing.
	•			Lifting Strap	Inspect for frays and cuts or signs of weakness.	Strap frayed, cut, or missing.
	•			Hand Control Harness	Check connections and quick-release coupling for proper fit and operation. Check safety cable for damage and security.	Damaged, or not operating properly. Safety cable damaged or missing.
	•			Primary and Secondary Hydraulic Manifolds	Check for leaks. Check hydraulic lines for proper routing.	Leaks exceed Class II.
			•	Pressure Gage (Primary Manifold)	Check gage pressure (should read 900-1200 psi); adjust if necessary.	Pressure not attainable.
8		•	Pressure Gage (Secondary Manifold)	Check gage pressure (should read 300 psi in all modes); adjust if necessary.	Pressure not attainable.	
	•	•	Liquid System Pump and Crosstube Assembly	Check all L-clamps for tightness. Check for cracked or broken ears on mounting plates. Check for leaks anywhere in system.	Leaks exceed Class II.	

**Table 2-4. Operator Level PMCS (Cont)**

NOTE: Within designated interval, these checks are to be performed in the order listed.

B-Before

D-During

A-After

ITEM NO.	INTERVAL			Item To Be Inspected	Procedures	EQUIPMENT IS NOT READY/AVAILABLE IF:
	B	D	A			
11	•		•	Strainer	Check for cleanliness; clean with water or appropriate solvent.	Strainer plugged.
	•	•		Pump and Crosstube Spray System Control Valve	Check hydraulic couplings for correct location and secureness of hookup. Check operation with hand control.	Fails to operate.
	•	•		Level Sensors	Check connections. Check for proper operation (indicator lights when bucket is empty).	Fails to operate.
	•			LV Booms and Struts	Check for proper assembly. Make sure all quick-release pins are secured.	Cannot be secured.
	•	•		Boom Kamlock Gaskets	Check for missing or compressed gaskets. Check for leaks.	Missing, or leaks exceed Class II.
	•	•		Spray Nozzles	Check for leaks using water. Check for correct/uniform spray pattern. If threads are stripped or body cracked, refer to unit maintenance.	Leaks exceed Class II, or spray produces excessively large droplets.
12	•	•		ULV Boom	Check for secure attachment, broken, or missing parts. Quick-release pins should be fully engaged.	Not secured, or broken.
	•	•		Boom Kamlock Gaskets	Check for missing or compressed gaskets. Check for leaks.	Missing, or leaks exceed Class II.
	•	•		Liquid Pesticide Lines	Check for leaks at all connections.	Leaks exceed Class II.
	•	•		Nozzles	Check for leaks using water.	Leaks exceed Class II.

**Table 2-4. Operator Level PMCS (Cont)**

NOTE: Within designated interval, these checks are to be performed in the order listed.

B-Before

D-During

A-After

ITEM NO.	INTERVAL			Item To Be Inspected	Procedures	EQUIPMENT IS NOT READY/AVAILABLE IF:
	B	D	A			
13	•	•		Hydraulic Lines	Check for proper hookup to pump and primary manifold. Check for leaks at manifold and rotary atomizers.	Leaks exceed Class II, or lines installed incorrectly.
	•	•		Rotary Atomizers	Check for secure mounting.  <b>WARNING</b>  Operator should be aware that foreign objects in slinger can cause injury when system is activated.	Mounting is loose.
	•	•		SD System Chutes	Check all L-clamps for tightness. Check for proper attachment of hydraulic lines. Check chute gates for smooth operation and tight closure.	Missing L-clamps cause leaks, or chute gates malfunction.
	•	•		Empty Sensor	Check empty sensor connection and operation.	Light on hand control unit inoperative.
14	•	•		SD System Slinger/Hopper Assembly	Check tightness of attachment hardware. Check for proper attachment of hydraulic lines. Check for proper activation by hand control. Check for foreign objects in slinger.	Hardware missing or slinger malfunctions.
15	•	•		Liquid System	Flush entire system including bucket, crosstube and pump assembly, booms, nozzles, liquid pesticide lines (ULV), and rotary atomizers using appropriate solvent.	All assemblies not properly cleaned.

**Table 2-4. Operator Level PMCS (Cont)**

NOTE: Within designated interval, these checks are to be performed in the order listed.

B-Before

D-During

A-After

ITEM NO.	INTERVAL			Item To Be Inspected	Procedures	EQUIPMENT IS NOT READY/AVAILABLE IF:
	B	D	A			
16			•	SD System	<p style="text-align: center;"><u><b>WARNING</b></u></p> <p>Personnel handling solid or liquid pesticides shall use appropriate personal protective equipment consisting of respirators, coveralls, rubber gloves, goggles, etc., as required by type of pesticide used and in accordance with manufacturer's label directions. Avoid direct contact with pesticide. Observe all warnings on label. Handle pesticide in well-ventilated area. Failure to do so could result in personal injury.</p> <p>Compressed air used for cleaning and drying purposes shall not exceed 30 psi. Use only with effective chip guarding and personal protective equipment (goggles/shield, gloves, etc.). Flying debris could cause personal injury.</p> <p>Clean out residual solid pesticide from bucket, chutes, and slinger using 30 psi compressed air.</p>	All assemblies not properly cleaned.
17			•	Exterior Surfaces	<p style="text-align: center;"><u><b>CAUTION</b></u></p> <p>Take care to avoid soaking electrical connections.</p> <p>Using soap and water, clean any surface contaminated with liquid pesticide. Dry any areas susceptible to corrosion.</p>	All assemblies not properly cleaned and dried.

### Section III. OPERATION UNDER USUAL CONDITIONS

#### 2-8. UNPACKING

Each PDU comes in three crates. Two of the crates, one containing the spray booms, the other containing the subassemblies, remote control, sling, and spare parts, should be reserved for storing and transporting components not in use. The PDU will normally have been unpacked by unit support personnel and will come to operations on its dolly. If you are uncrating the PDU, observe the following:

- a. Save all cushioning material.
- b. When uncrating spray boom and struts, separate left and right LV spray boom parts by using code system stamped on parts.

#### **CAUTION**

Spray nozzle and rotary atomizers are delicate. Handle parts carefully to avoid damaging equipment.

- c. Uncrate spray nozzle and rotary atomizers carefully.
- d. Inspect all components for damage using table 2-4. Check for missing parts using Appendix C, Components of End Item and Basic Issue Items Lists.

#### 2-9. PREPARATION FOR USE

Assemble the PDU for low volume (LV) system, ultra-low volume (ULV) system, or dry (SD) system operation in accordance with the following paragraphs.

- a. Perform all before (B) PMCS from table 2-4 to ensure all fluid levels are up and equipment is in ready status before operation of PDU. Performing all (B) PMCS represents pre-start instructions.
- b. Ensure engine is OFF and tail fin is installed.
- c. Open petcock (1, figure 2-4) on fuel strainer (2).
- d. Prep and install battery.
  - (1) Remove battery cover (1, figure 2-5) by removing two nuts (2) and two washers (3).
  - (2) Disconnect two battery cables (4) from battery (5) by removing two locknuts (6).
  - (3) Remove four jam nuts (7), two flat washers (8), and two insulator washers (9) from two holddown bolts (10).

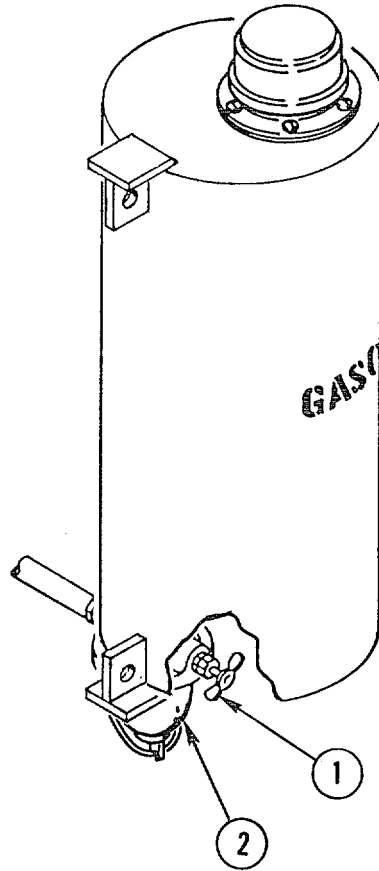

**Figure 2-4. Fuel Strainer Petcock**

- (4) Remove holddown crossbar (11) and two holddown bolts (10). Remove battery (5) from pad (12).
- (5) Fill battery with electrolyte (item 6, Appendix E) to level indicated on battery.
- (6) Install battery (5, figure 2-5) on battery pad (12).
- (7) Hook two holddown bolts (10) on battery pad (12) and install holddown crossbar (11).
- (8) Install two insulator washers (9), two flat washers (8), and four jam nuts (7) on holddown bolts (10).

**NOTE**

Battery cables are color-coded for connection. Red is positive. Black is negative.

- (9) Connect two battery cables (4) to battery (5) and install two locknuts (6).

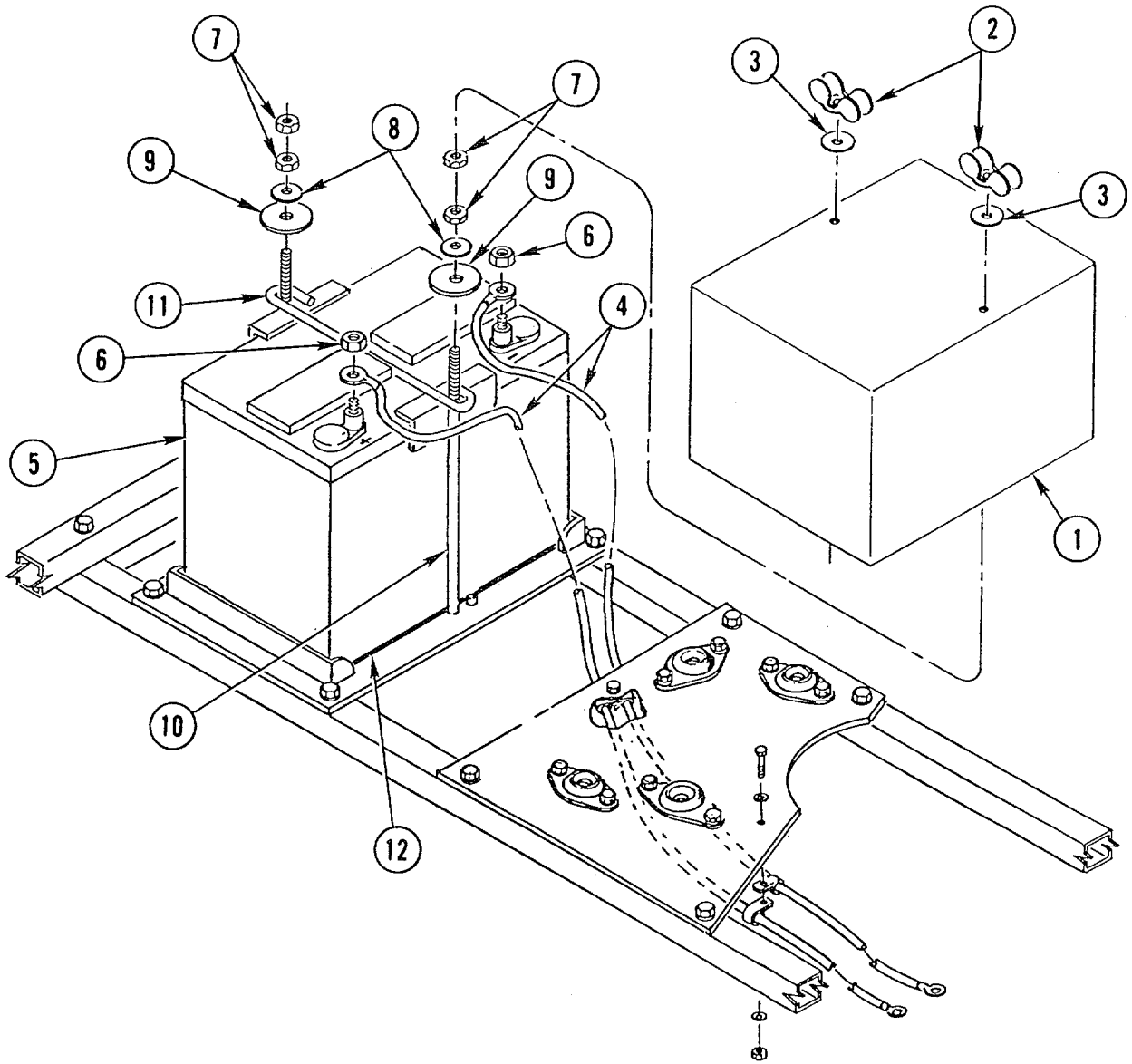

Figure 2-5. Battery Installation



- (10) Install battery cover (1), aligning holes on cover with battery holddown bolts (10).
- (11) Secure battery cover (1) using two washers (3) and two nuts (2).
- e. Fill bucket with water and check for leaks. Drain bucket.
- f. Assemble the PDU for LV system operation.

#### NOTE

Both LV boom assemblies are assembled/installed the same way. The following procedure is for the left-side LV boom assembly.

Booms and struts are number and color-coded; right is green and red is left. The Connect Points referred to in this procedure are the places on the boom assembly where struts and booms with like colors and numbers are to be joined.

Strut tabs must point up. Nozzles must face rear of bucket. End of strut should be at a 15-degree angle to centerline of boom.

- (1) Connect Points 1 and 2: Install two struts (1 and 2, figure 2-6) at top of right bucket leg weldments and secure to strut anchors (3 and 4) using two quick-release pins (5 and 6).
- (2) Install outboard boom weldment (7) on center boom weldment (8) of pump and crosstube assembly. Secure by closing Kamlock ears over end of boom weldment. Do not install clamp (9) at this time.
- (3) Connect Point 3: Using upward pressure, connect other ends of struts (1 and 2) to outboard boom weldment (7) at Connect Point 3 using quick-release pin (10).
- (4) Connect Point 4: Attach struts (11 and 12) to outboard boom weldment (7) at Connect Point 4 using quick-release pin (13).
- (5) Connect Points 5 and 6: Attach opposite ends of struts (11 and 12) to eyebolts on cross strut (14) at Connect Points 5 and 6 using quick-release pins (15 and 16).
- (6) Connect Point 10: Install outboard boom weldment (17) on outboard boom weldment (7) Secure by closing Kamlock ears over connection. Do not install clamp (18) over ears at this time.
- (7) Connect Point 7: Attach struts (19 and 20) to outboard boom weldment (17) at Connect Point 7 using quick-release pin (21).
- (8) Connect Points 8 and 9: While supporting end of weldment (17), connect cross strut (14) to struts (1, 2, 19, and 20) at Connect Points 8 and 9 using quick-release pins (22 and 23).
- (9) Connect Point 11: Install boom extension (24) on end of boom weldment (17) and secure by closing Kamlock ears over connection.

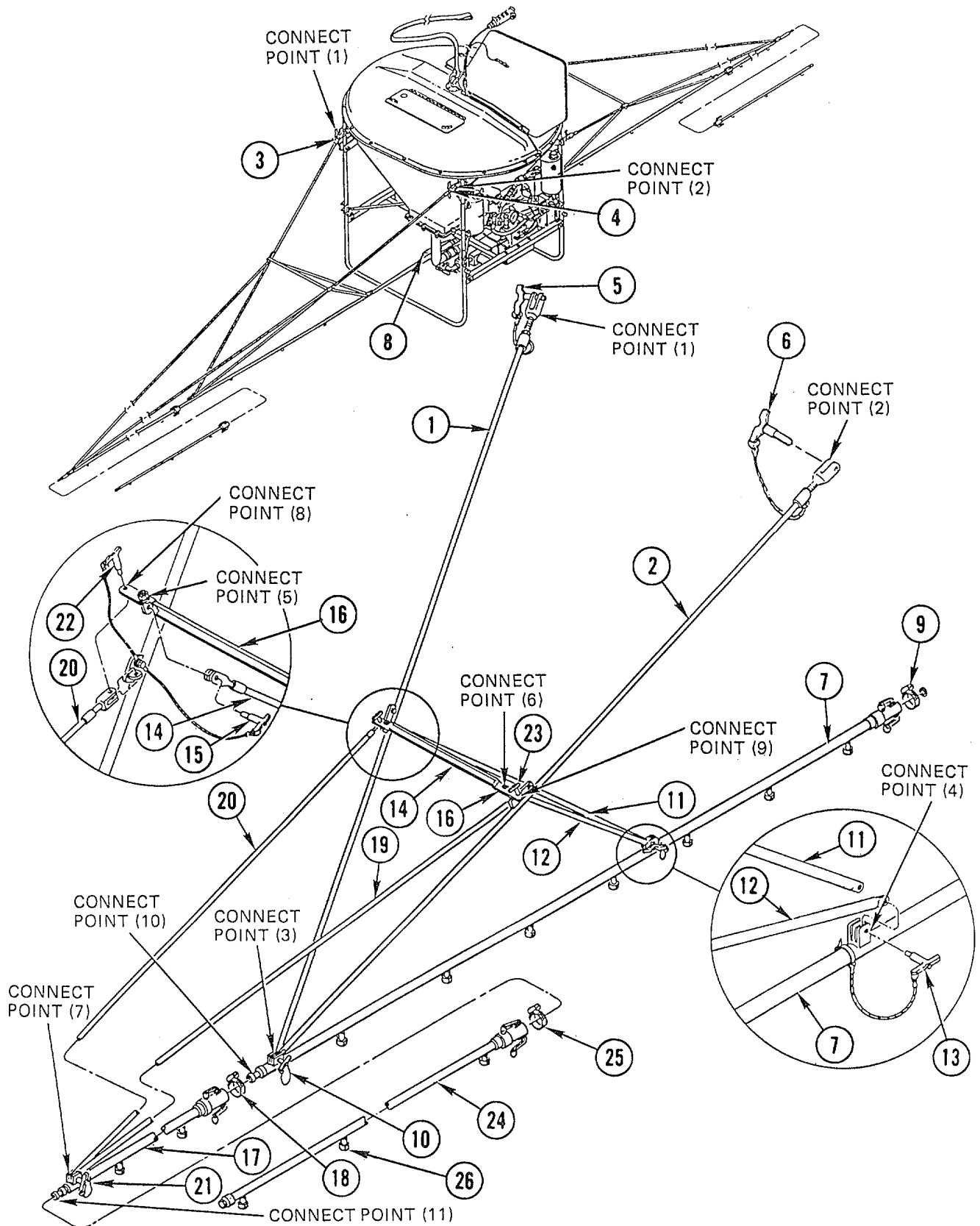

Figure 2-6. Assembly of LV System

- (10) Install clamps (9, 18, and 25) over Kamlock ears and through rings on booms and tighten.
- (11) Complete operational test and pressure checks (para 2-10).

**WARNING**

Personnel handling solid or liquid pesticides shall use appropriate personal protective equipment consisting of respirators, coveralls, rubber gloves, goggles, etc., as required by type of pesticide used and in accordance with manufacturer's label directions. Avoid direct contact with pesticide. Observe all warnings on label. Handle pesticide in well-ventilated area. Failure to do so could result in personal injury.

- (12) Load bucket with appropriate pesticide in accordance with pesticide label directions.

g. Assemble the PDU for ULV system operation.

- (1) Attach ULV boom (1, figure 2-7) to ULV attachment points on bucket frame using two quick-release pins (2 and 3).
- (2) Attach Kamlock hose ends (4 and 5) over crosstube to center boom (6). Secure by closing Kamlock ears (7).
- (3) Install clamps (8) over Kamlock ears (7) and tighten.
- (4) Attach hydraulic quick-disconnect fitting (9) to hydraulic motor.
- (5) Attach hydraulic quick-disconnect fitting (10) to hydraulic filter elbow fitting.
- (6) Make sure ball valve (11) is completely closed and crosstube gate valve (12) is open.
- (7) Complete operational test (para 2-10).

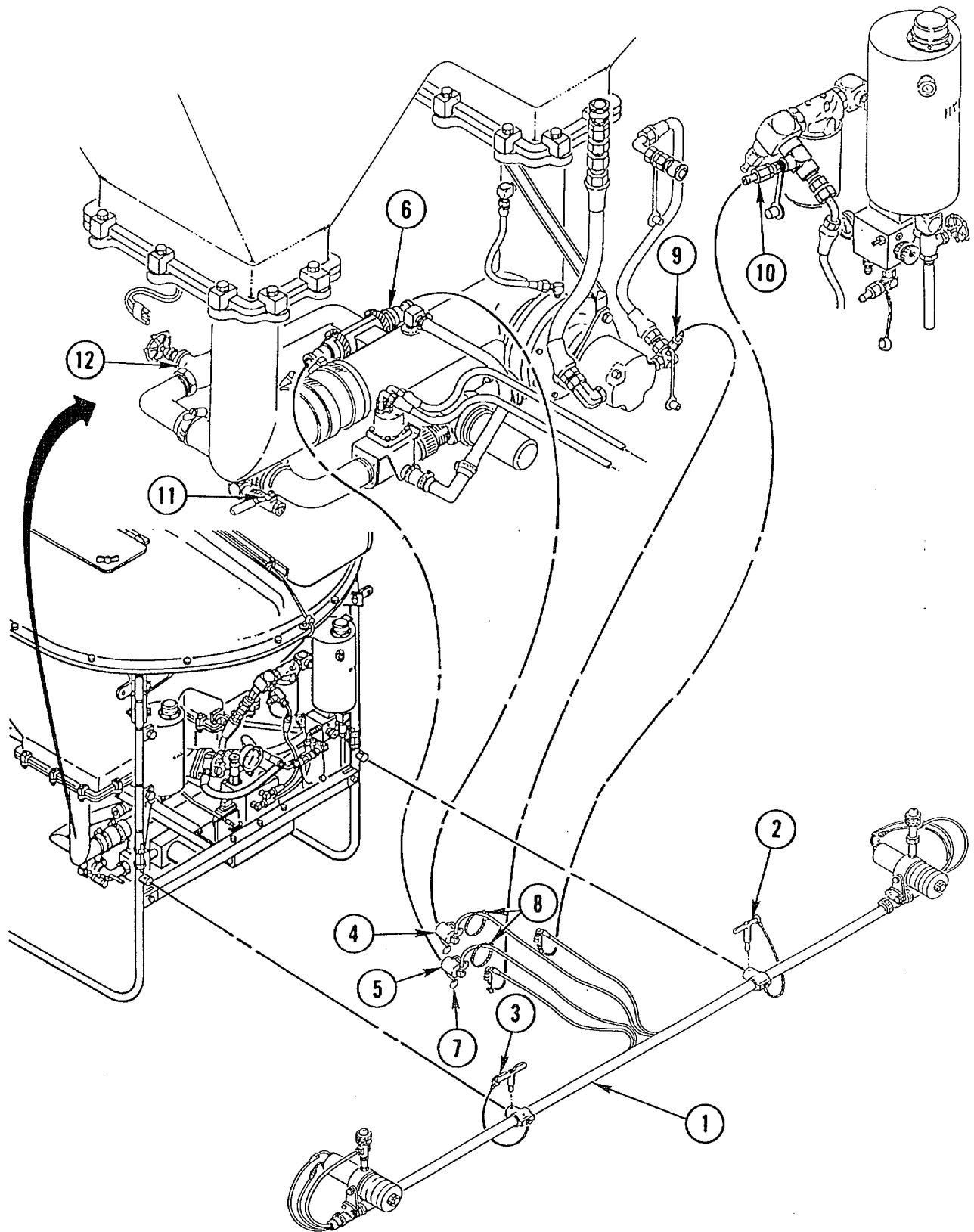

Figure 2-7. Assembly of ULV System

h. Assemble the PDU for SD system operation.

**WARNING**

Make sure muffler and engine are cooled down before attempting assembly, disassembly, or adjustments. Hot muffler and engine components can cause burns.

- (1) Disconnect two hydraulic fittings (1 and 2, figure 2-8) at secondary manifold.
- (2) Disconnect hydraulic fitting (3) from hydraulic filter. Plug fitting.
- (3) Disconnect hydraulic fitting (4) from primary manifold. Plug fitting.
- (4) Disconnect capacitive light switch wiring harness (5) from bucket harness.
- (5) Using a suitable clamping device, clamp both crosstube downspouts and remove 20 locknuts (6), 20 flat washers (7), 20 bolts (8), 20 flat washers (7), and 20 clips (9).

**NOTE**

Two people are required to support and remove pump and crosstube assembly.

- (6) Loosen hose clamp (10) on crosstube and remove left downspout.
- 7) Remove clamping device. Carefully lower and remove pump and crosstube assembly from bucket.

**NOTE**

Procedure is the same for left and right hopper assemblies, except left hopper assembly capacitive switch wiring harness has two three-pole connectors and attaches to both right hopper assembly and bucket harness.

- (8) Install left and right hopper assemblies (11 and 12) under bucket with capacitive light switch wiring harnesses (13) toward rear, cylinder (14) quick-disconnect fittings aligned 51 degrees in toward center of bucket under bucket, and cylinders facing toward front.

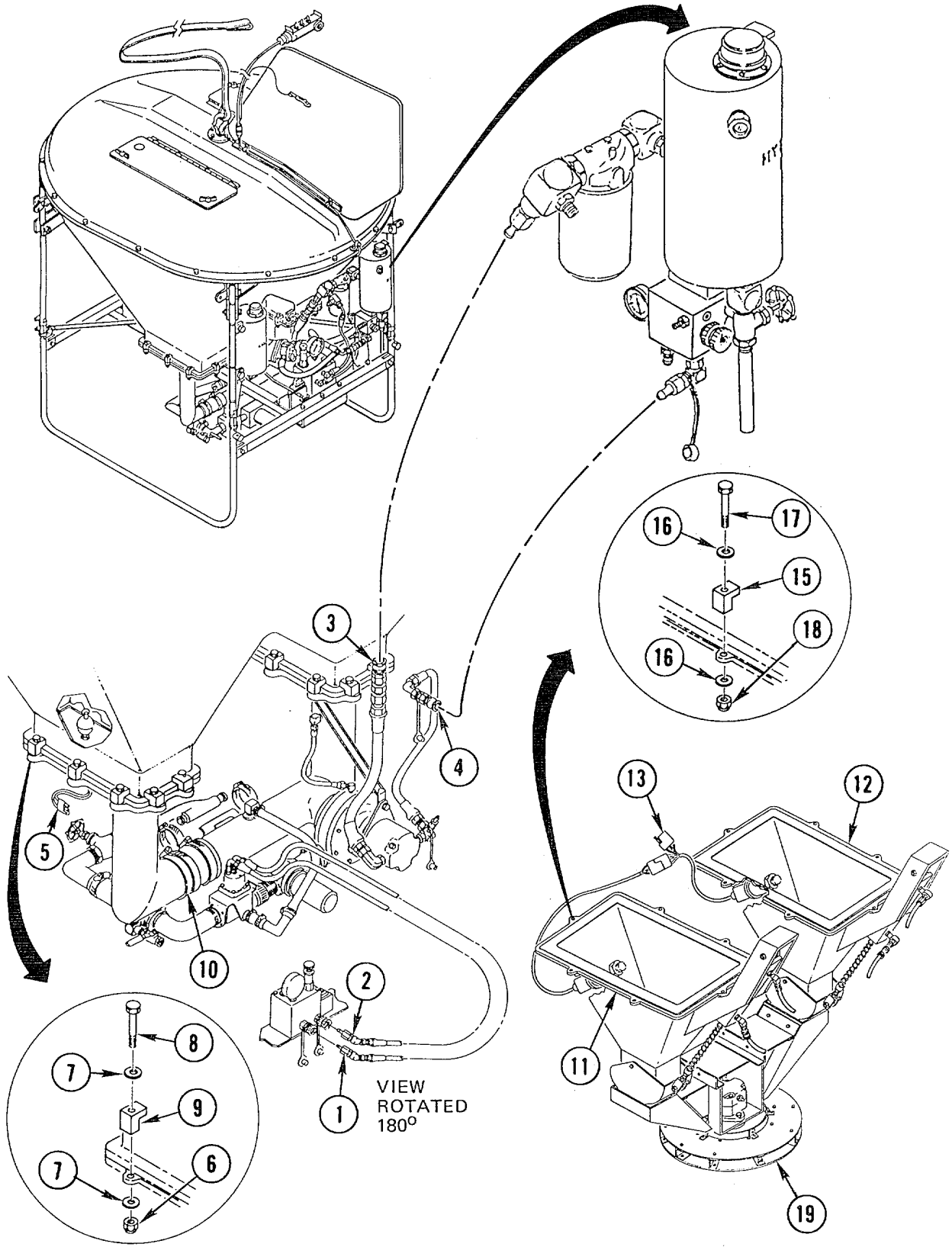

Figure 2-8. Assembly of SD System (Sheet 1 of 2)

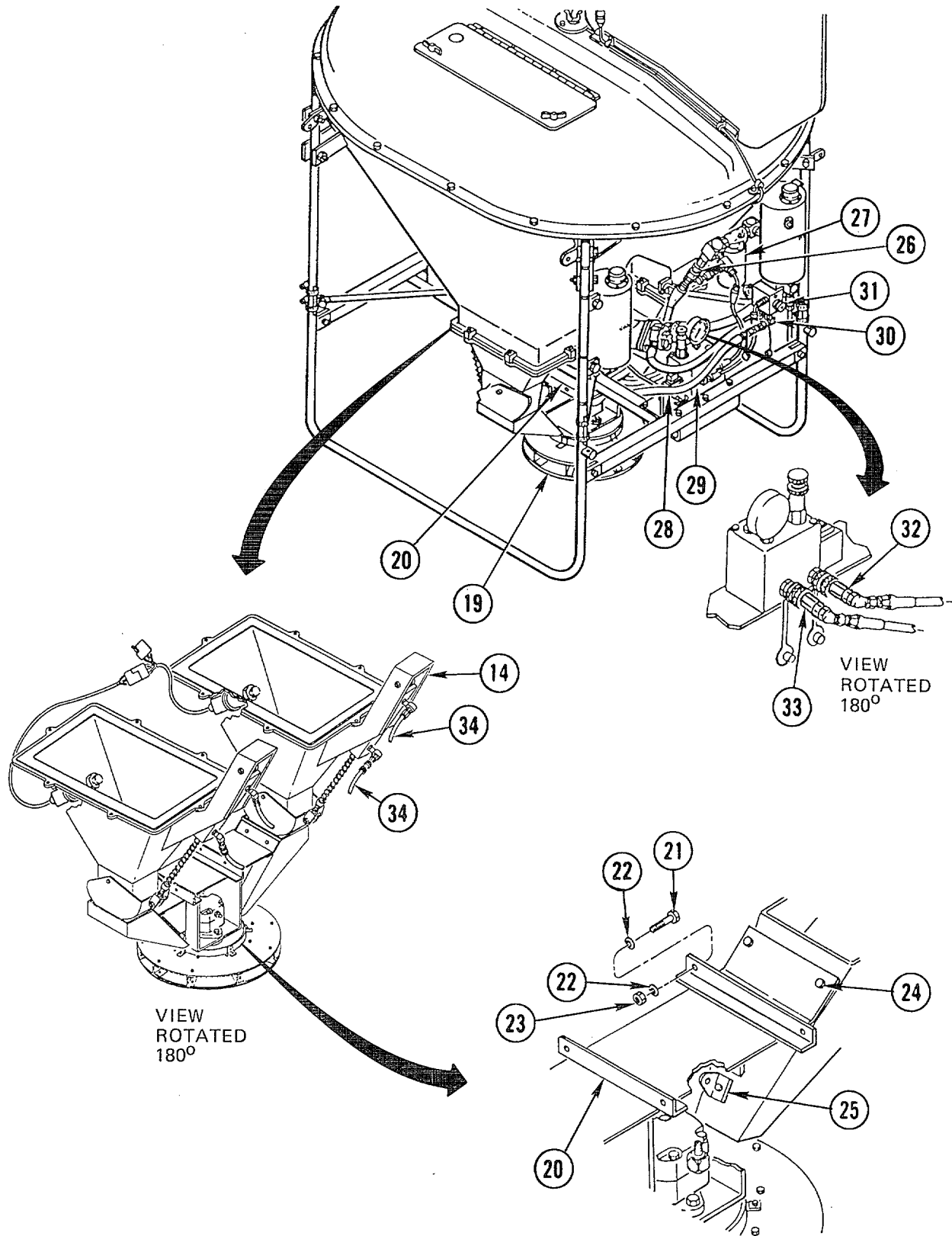

Figure 2-8. Assembly of SD System (Sheet 2 of 2)

- (9) Align hopper assembly (11) mounting holes with downspout mounting holes.
- (10) Secure hopper assembly (11) to bucket using 6 clips (15), 12 lockwashers (16), 6 bolts (17), and 6 nuts (18). Hand-tighten nuts (18) loosely until motor and slinger assembly has been installed and adjusted.
- (11) Repeat steps (9) and (10) to install other hopper assembly (12).
- (12) Connect left and right capacitive light switch wiring harnesses (13) to each other. Connect left hopper assembly capacitive light switch wiring harness (5) to bucket wiring harness.

**NOTE**

Two people are required to install the motor and slinger assembly.

- (13) Install motor and slinger assembly (19) under bucket and secure to engine platform (20) using four bolts (21), eight washers (22), and four nuts (23). Hand-tighten nuts loosely to allow for adjustment of chutes.
- (14) Using a 3/8-in. open-end box-end wrench, loosen two chute inner bolts (24). Using a 3/8-in. socket-end wrench, loosen nut on lower bracket (25). Adjust chute up or down and pivot chute assembly as required to allow free motion of hopper and slinger. Tighten hardware.
- (15) Remove cap and connect 3/4-in. hose (26) to quick-disconnect fitting on back of hydraulic filter (27).
- (16) Route 1/2-in. hydraulic hose (28) under throttle cable and in front of secondary hydraulic manifold (29). Connect hose (28) to front, bottom quick-disconnect fitting (30) on primary hydraulic manifold (31).
- (17) Connect two 1/4-in. hydraulic fittings (32 and 33) to back of secondary hydraulic manifold (29), matching up markings on fittings with markings on manifold (A to A, B to B).
- (18) Remove caps and connect four hydraulic fittings (34) to two hopper cylinders (14).
- (19) Hand spin slinger to ensure freedom of movement. Check for loose connections and foreign objects.
- (20) Complete SD system operational test (para 2-10).



## 2-10. INITIAL ADJUSTMENTS AND TESTS

The following paragraphs provide the initial adjustments and tests required before operating the PDU. Operator procedures consist of hydraulic system pressure and operational tests and pesticide application rate adjustments for each operating configuration.

### NOTE

Secondary hydraulic manifold should be adjusted to 300 psi in all modes of operation.

#### a. LV System Boom Assembly Pressure Adjustment.

### WARNING

Personnel handling solid or liquid pesticides shall use appropriate personal protective equipment consisting of respirators, coveralls, rubber gloves, goggles, etc., as required by type of pesticide used and in accordance with manufacturer's label directions. Avoid direct contact with pesticide. Observe all warnings on label. Handle pesticide in well-ventilated area. Failure to do so could result in personal injury.

### NOTE

All initial tests should be performed with water only. All following tests for calibration should be performed with pesticide.

- (1) Remove center nozzle from left or right boom and install test tee, pressure gage, and nozzle.
- (2) Fill bucket with pesticide. Use sight gage on side of bucket.
- (3) Make sure gate valve on crosstube assembly is open.
- (4) Connect hand control assembly to wiring harness.
- (5) On hand control, make sure SYSTEM switch is set to OFF and POWER switch is ON.
- (6) Set key on engine to ON.
- (7) Start engine with ENGINE START switch.
- (8) Set SYSTEM switch to ON. Check for hydraulic leaks, that EMPTY indicator is not lit, and that pressure gage on primary hydraulic manifold assembly indicates 900-12900 psi.

**WARNING**

Make sure muffler and engine are cooled down before attempting assembly, disassembly, or adjustments. Hot muffler and engine components can cause burns.

- (9) If pressure is now between 900-1200 psi, loosen jam nut (1) on primary manifold pressure adjustment knob (2), shown in figure 2-9, and adjust knob for desired boom pressure.

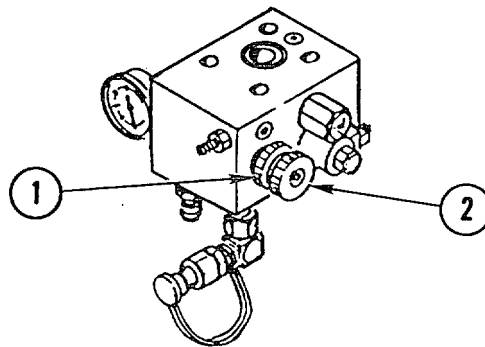

**Figure 2-9. LV Boom Pressure Assembly Adjustment**

**NOTE**

Turning knob clockwise decreases pressure; counterclockwise increases pressure.

- (10) Tighten jam nut (1) and repeat steps (8) and (9) until pressure is correct.

**CAUTION**

Do not run system longer than 3 minutes after EMPTY indicator lights, or damage to pump could occur.

- (11) When adjustment is complete, or if EMPTY indicator lights, set SYSTEM switch to OFF, POWER switch to OFF, and key on engine to OFF.

(12) Remove nozzle, pressure gage, and test tee. Install nozzle back in boom.

b. ULV System Boom Assembly Pressure Adjustment.

**WARNING**

Personnel handling solid or liquid pesticides shall use appropriate personal protective equipment consisting of respirators, coveralls, rubber gloves, goggles, etc., as required by type of pesticide used and in accordance with manufacturer's label directions. Avoid direct contact with pesticide. Observe all warnings on label. Handle pesticide in well-ventilated area. Failure to do so could result in personal injury.

**NOTE**

All initial tests should be performed with water only. All following tests for calibration should be performed with pesticide.

(1) Remove fitting (1) from rotary atomizer nozzle (2) and install test tee (3), pressure gage (4), and fitting (1) as shown in figure 2-10.

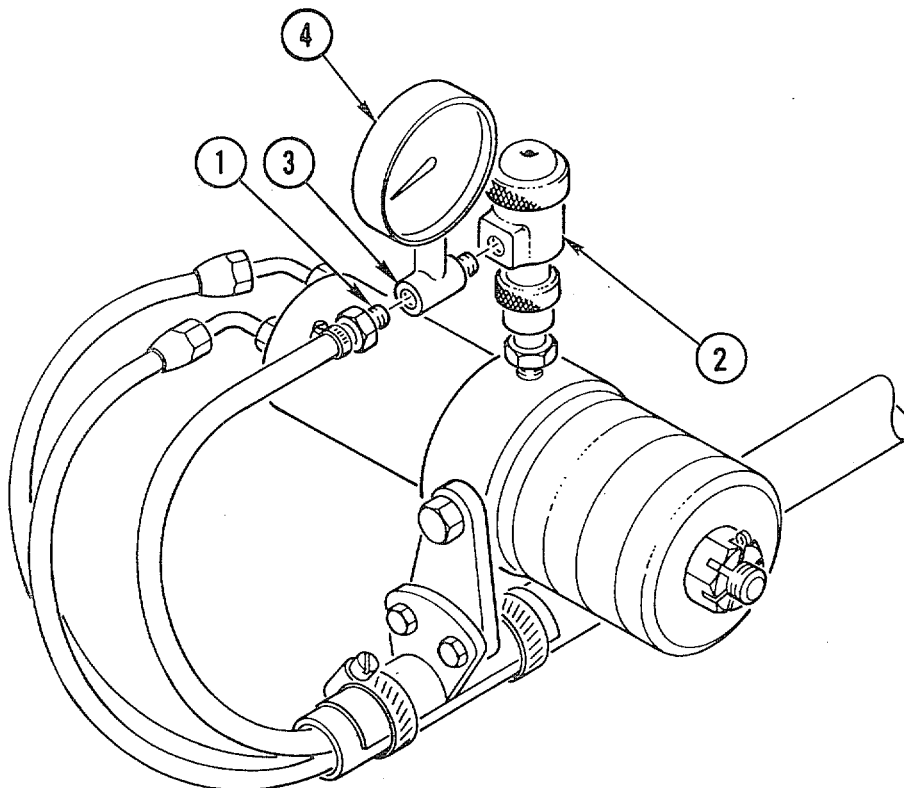

**Figure 2-10. ULV Boom Pressure Adjustment**

- (2) Fill bucket assembly with pesticide. Use sight gages on side of tank.
- (3) Connect hand control assembly to wiring harness.
- (4) On hand control, make sure SYSTEM switch is set to OFF and POWER switch is ON. Make sure gate valve is open.
- (5) Set key on engine to ON.
- (6) Start engine with ENGINE START switch.
- (7) Set SYSTEM switch to ON. Check for hydraulic leaks, that EMPTY indicator is not lit, and that pressure gage on secondary hydraulic manifold assembly indicates 300 psi.

**WARNING**

Make sure muffler and engine are cooled down before attempting assembly, disassembly, or adjustments. Hot muffler and engine components can cause burns.

- (8) If pressure is not 300 psi, loosen jam nut on secondary manifold pressure adjustment knob and adjust knob for desired pressure.
- (9) Tighten jam nut and repeat steps (7) and (8) until pressure is correct.

**CAUTION**

Do not run system longer than three minutes after EMPTY indicator lights, or damage to pump could occur.

- (10) When adjustment is complete, or if EMPTY indicator lights, set SYSTEM switch to OFF, POWER switch to OFF, and key on engine to OFF.
  - (11) Remove fitting (1), pressure gage (4), and test tee (3). Install fitting (1) back into nozzle.
- c. LV System Operational Test. This test consists of verifying PDU function and final adjustment of application rate. Sample flow rates using water at ambient temperature of 70°F (21.1°C) are given in table 2-5. Rates will vary with temperature, humidity, if chemicals are used, oil temperature, and other conditions.

- (1) Fill bucket assembly with pesticide. Use sight gages on side of tank.
- (2) Connect hand control assembly to wiring harness.

Table 2-5. LV System Flow Rate -Water

Primary Hyd Pressure	Boom Pressure	D4-45 Nozzle Flow
300 psi	20 psi	8.5 gpm
450 psi	30 psi	10.5 gpm
500 psi	40 psi	12.2 gpm
675 psi	50 psi	13.6 gpm

- (3) On hand control, make sure SYSTEM switch is set to OFF and POWER switch is ON. Make sure gate valve is open.
- (4) Place bucket under nozzle.
- (5) Set key on engine to ON.
- (6) Start engine with ENGINE START switch.

**CAUTION**

Note time before performing step (7) since application rate can only be determined if dispersal time is known. During ground test, 30-minute operating time should not be exceeded; overheating and damage to equipment will occur.

- (7) Note time and set SYSTEM switch to ON. Check for hydraulic leaks, that EMPTY indicator is not lit, and that pressure gage on secondary hydraulic manifold assembly indicates 300 psi.
- (8) Press DISPERSAL pushbutton. After pre-determined time is up, release DISPERSAL pushbutton and set SYSTEM switch to OFF.
- (9) Measure amount of pesticide collected in bucket and calculate application rate (para 2-10, f). If application rate is incorrect, proceed with step (10). If application rate is correct, proceed with step (12).
- (10) Loosen jam nut, adjust manifold pressure adjustment knob, then tighten jam nut.
- (11) Repeat steps (7) through (10) until application rate is correct.

**CAUTION**

Shut down hydraulic system immediately when EMPTY indicator lights, or damage to pump could occur.

- (12) When application rate is correct, or if EMPTY indicator lights, set SYSTEM switch to OFF, POWER switch to OFF, and key on engine to OFF.

d. ULV System Operational Test. This test consists of verifying PDU function and final adjustment of application rate.

**WARNING**

Personnel handling solid or liquid pesticides shall use appropriate personal protective equipment consisting of respirators, coveralls, rubber gloves, goggles, etc., as required by type of pesticide used and in accordance with manufacturer's label directions. Avoid direct contact with pesticide. Observe all warnings on label. Handle pesticide in well-ventilated area. Failure to do so could result in personal injury.

- (1) Fill bucket assembly with pesticide. Use sight gages on side of tank.
- (2) Connect hand control assembly to wiring harness.
- (3) On hand control, make sure SYSTEM switch is set to OFF and POWER switch is ON. Make sure gate valve is open.
- (4) Disconnect pesticide hose (1, figure 2-11) on both ends at adjuster fittings.

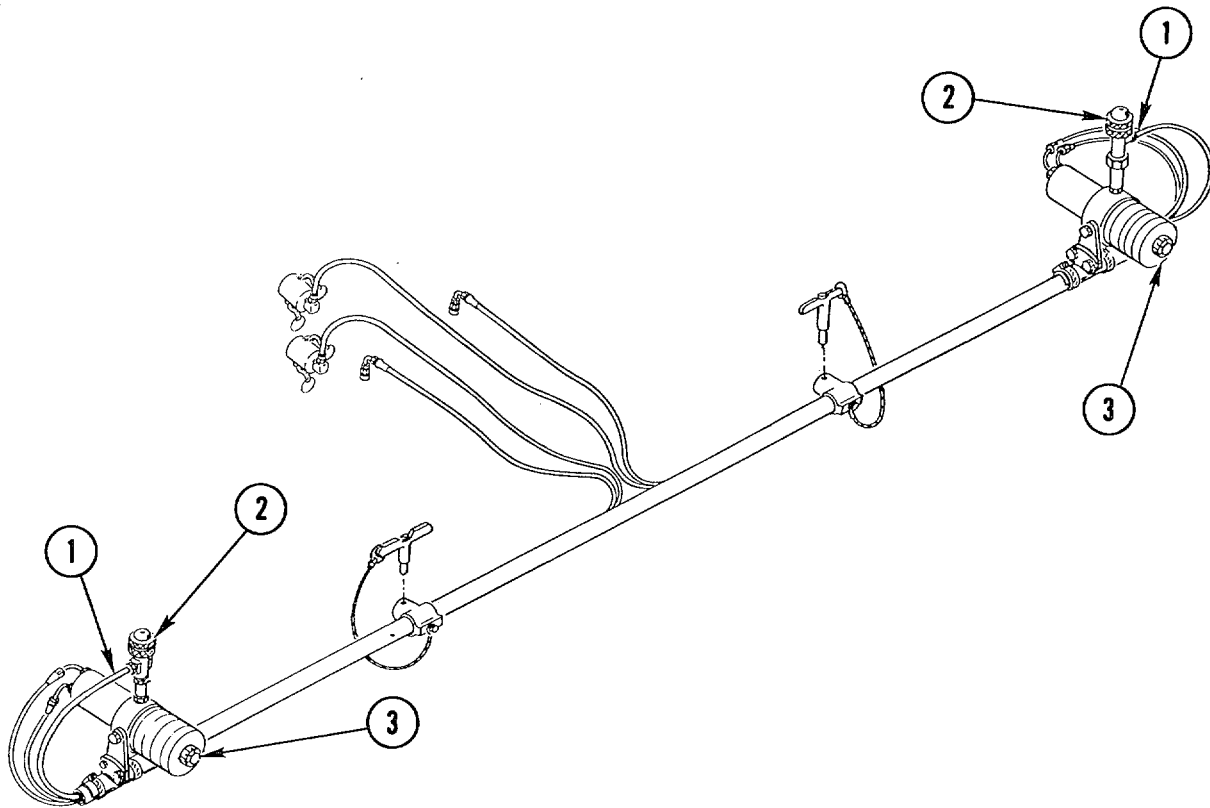

**Figure 2-11. ULV System Operational Test**

- (5) Remove nozzles (2) from rotary atomizers (3) and install nozzles (2) on pesticide hose (1).
- (6) Place both fittings with nozzles in graduated container.
- (7) Set key on engine to ON.
- (8) Start engine with ENGINE START switch.

**CAUTION**

Note time before performing step (9) since application rate can only be determined if dispersal time is known. During ground test, 30-minute operating time should not be exceeded; overheating and damage to equipment will occur.

- (9) Note time and calculate desired flow rate in accordance with pesticide label instructions and the following procedures.
  - (a) Set SYSTEM switch to ON. Check for hydraulic leaks, that EMPTY indicator is not lit, and that pressure gage on secondary hydraulic manifold assembly indicates 300 psi.
  - (b) Press DISPERSAL pushbutton. After pre-determined time is up, release DISPERSAL pushbutton and set SYSTEM switch to OFF.
  - (c) Measure amount of pesticide collected in bucket and calculate application rate (para 2-10, f). If application rate is incorrect, proceed with step (10). If application rate is correct, proceed with step (12).
- (10) Loosen jam nut on primary manifold adjustment knob and adjust manifold pressure. Tighten jam nut.
- (11) Repeat steps (9) and (10) until application rate is correct.

**CAUTION**

Do not run system longer than 3 minutes after EMPTY indicator lights, or damage to pump could occur.

- (12) When application rate is correct, or if EMPTY indicator lights, set SYSTEM switch to OFF, POWER switch to OFF, and key on engine to OFF.
- e. SD System Operational Test. This test consists of verifying PDU function and final adjustment of application rate. Sample flow rates using Agrisect pesticide are given in table 2-6.

Table 2-6. Flow Rate - Agrisect

Meter Setting	Flow Rate, Both Hoppers (Lb/Min)
0	0
1	3
2	11
3	25
4	42
5	80
6	115
7	150
8	190
9	238
10	298

**NOTE**

Slinger assembly should be removed for this test (para 4-51).

- (1) Set metering plate to desired opening by sliding forward or back.
- (2) Ensure that hoppers are closed (cylinders fully extended).
- (3) Connect hand control assembly to wiring harness.
- (4) Place container under each hopper.
- (5) On hand control, make sure SYSTEM switch is set to OFF and POWER switch is ON.
- (6) Set key on engine to ON.

---

**WARNING**

---

Operator should be aware that foreign objects in slinger can cause injury when system is activated.

- (7) Start engine with ENGINE START switch.



**NOTE**

Note time before performing step (8) since application rate can only be determined if dispersal time is known.

- (8) Note time and set SYSTEM switch to ON. Check for hydraulic leaks, that EMPTY indicator is not lit, and that pressure gage on secondary hydraulic manifold assembly indicates 300 psi.
- (9) Press DISPERSAL pushbutton. After pre-determined time is up, release DISPERSAL pushbutton and set SYSTEM switch to OFF.
- (10) Measure amount of material collected in bucket and calculate application rate (para 2-10, f). If application rate is incorrect, proceed with step (11). If application rate is correct, proceed with step (13).

---

**WARNING**

---

Make sure muffler and engine are cooled down before attempting assembly, disassembly, or adjustments. Hot muffler and engine components can cause burns.

- (11) Adjust metering plate as necessary to increase or decrease application.
- (12) Repeat steps (8) through (11) until application rate is correct.
- (13) When adjustment is complete or if EMPTY indicator lights, set SYSTEM switch to OFF, POWER switch to OFF, and key on engine to OFF.
- (14) Make sure metering plate fasteners are tightened after adjustment.
- (15) Position slinger assembly under tank and secure to brackets.

**f. Adjusting Application Rate.**

The following paragraphs provide procedures for computing the application rate needed to apply a desired amount of pesticide evenly over a defined area. Factors to consider are: amount of pesticide that must be applied, air speed and altitude of helicopter, effective swath width of application, and, for LV system application, the gpm for each nozzle. The amount of pesticide to be applied to a given area is determined by the type of pesticide used, the terrain and foliage of the application area, and the target pest. Nozzle selection and system calibration procedures are contained in Appendix G.

- (1) LV and ULV Systems Adjustment. The required information is gallons (pints) per application (gpa), gallons applied per minute (gpm), helicopter speed (mph), swath width (SW), number of nozzles (NOZ), and boom pressure (psi). The first calculation should be swath width (SW). Swath width can vary for different types of pesticides, ULV system spraying, and different altitudes.

- of
- (a) Calculate Swath Width (SW). Effective swath width can vary with altitude, speed, type of application, and wind speed. Determine swath width with a few test runs. LV system applications have an approximate SW 150-350 ft at 100-ft altitude; ULV system applications are approximately 100-200 ft at 100-ft altitude.
  - (b) Formulate Desired Flow Rate. Once the swath width is known, calculate the desired gallons per minute as follows:

$$GPM = \frac{GPA \times MPH \times SW}{495}$$

where GPA is in gallons, MPH is miles per hour, and SW is in feet.

Example: 1 gallon per acre, air speed of 55 mph, and a swath width of 200 feet:  $(1 \times 55 \times 200)/495 = 22.2$  gallons per minute.

This figure is now compared with actual gpm, which was computed in operational test. Adjust hydraulic pressure to bring actual gpm up or down to match desired gpm. For LV systems, this figure must be divided by number of nozzles (34). Different nozzles can then be selected to match desired gpm.

$$GPM/NOZ = \frac{GPA \times MPH \times SW}{\# NOZ \times 495}$$

Example:  $(1 \times 55 \times 200) = 0.65$ gpmpernozzle  
(34 x 495)

- (2) SD System Adjustment. To determine the desired meter setting, you must know the flight speed, the swath width, the flow rate of the material being used at each meter setting, and the desired application rate in pounds per acre. Once you know these variables, you can use the following formula to choose a meter setting:

**NOTE**

Excessive wind or an increase in flight altitude will have significant effect on swath width as well as accuracy of application positioning.

$$Flow Rate (lb/min) = \frac{App Rate (lb/acre) \times SW \times MPH}{495}$$

- (a) Meter Settings. After determining required flow rate, select proper meter setting to provide flow rate. If pesticide being used is Agrisect, refer to table 2-6. For Agrisect, swath width will normally be 55 ft, assuming flight altitude of approximately 50 ft and minimal wind factor. If pesticide other than Agrisect is being used, a new flow rate table is necessary. Perform the following:

- 1 Install left and right hopper assemblies on PDU. Place large container under each hopper assembly.
- 2 Remove slinger assembly from PDU.

- 3 Set primary manifold pressure at 1200 psi.
- 4 Set both meters to same setting.

---

**WARNING**

---

Personnel handling solid or liquid pesticides shall use appropriate personal protective equipment consisting of respirators, coveralls, rubber gloves, goggles, etc., as required by type of pesticide used and in accordance with manufacturer's label directions. Avoid direct contact with pesticide. Observe all warnings on label. Handle pesticide in well-ventilated area. Failure to do so could result in personal injury.

- 5 Fill left and right hopper assemblies with pesticide.
  - 6 Open left and right hopper assemblies for 1 minute and record weight of material in each container. (Be sure to subtract weight of container itself.) Repeat.
  - 7 Change both meter settings to same setting.
  - 8 Repeat steps 6 and 7 for each meter setting, then determine average flow rate (lb/min) for both hopper assemblies.
  - 9 Repeat step 6 if one of the four weights for meter setting is significantly different from others.
- (b) Swath "Width. If new pesticide is being used, or flight altitude is to be over 50 ft, it is advisable to determine actual swath width. Perform the following:

---

**WARNING**

---

Personnel handling solid or liquid pesticides shall use appropriate personal protective equipment consisting of respirators, coveralls, rubber gloves, goggles, etc., as required by type of pesticide used and in accordance with manufacturer's label directions. Avoid direct contact with pesticide. Observe all warnings on label. Handle pesticide in well-ventilated area. Failure to do so could result in personal injury.

- 1 Fully assemble PDU for SD system operation and fill left and right hopper assemblies with desired pesticide or similar material with same density and particle size.

- 2 Place approximately 20 waste containers perpendicular to line of flight of helicopter, spaced 5 ft apart on level ground.
- 3 Fly PDU over center of line of containers while pesticide is being dispersed at maximum flow setting.
- 4 Inspect each container until pesticide appears to be falling in area of containers (figure 2-12).
- 5 Empty all containers and fly over them repeatedly at same elevation, on same line of flight, and at desired application speed.
- 6 Repeat until there is readily measurable amount of material in fullest containers. Record amount of material (by volume, weight, or number of particles) in each container, and container's distance to right or left of line of flight. After this information has been recorded for at least two separate tests, it will be possible to establish effective swath width and create new flow rate table.
- 7 Refer to (a) above, Meter Settings, to determine meter setting required to obtain desired coverage (lb/acre).

## 2-11. ATTACHING PDU TO HELICOPTER

### WARNING

Ground personnel must be aware of their position in relation to helicopter at all times to prevent personal injury. Ground personnel involved in ground operation of PDU and/or helicopter shall wear protective head gear for ears and eyes to prevent personal injury.

A hovering helicopter (in the air) will create static electricity which exposes personnel to an electrical shock hazard. To avoid electrical shock during the electrical hookup, the groundperson should hold the insulated wires and tap the metal connectors together. This will discharge the static electricity. Alternative methods are the use of a grounding rod and chain, a discharge wand, or touching the helicopter down just before hookup.

### NOTE

Three persons, in addition to helicopter crew chief, are required to operate PDU. Groundperson 1 should be positioned in front of PDU. Groundperson 2 should be positioned to signal helicopter pilot. Groundperson 2 should be well versed in hand signals. Ground personnel should be upwind of PDU. Third person operates PDU from helicopter.

- a. Groundperson 1: Open crosstube gate valve and set PDU engine key to ON.

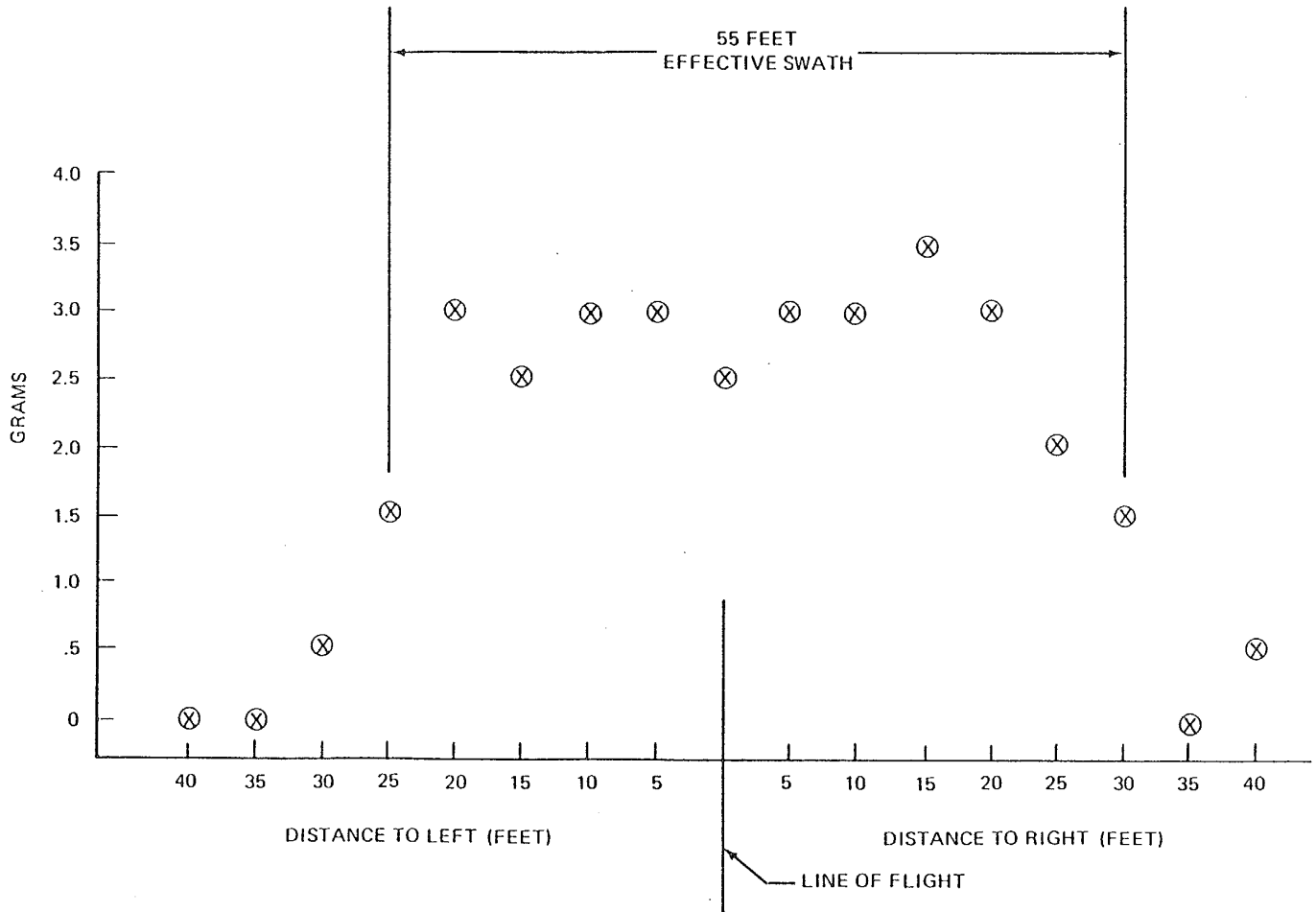

Figure 2-12. Effective Swath Width

**NOTE**

Helicopter crew chief and groundperson 2 direct helicopter pilot. Groundperson 2 must always be in front of pilot.

- b. Groundperson 2: Face PDU with arms raised above head and in sight of helicopter pilot at all times. Use appropriate hand signals to alert pilot (figure 2-13).

**NOTE**

Operator with hand control assembly is positioned at helicopter right-side cargo door.

- c. Operator: Attach lifting strap to helicopter cargo hook as shown in figure 2-14.
- d. Helicopter pilot: Lift off and fly to PDU location.
- e. Groundperson 2: As helicopter hovers over PDU, move 45 ft to right and remain in pilot's view at all times.
- f. Operator: Play hand control assembly cable out open right-side cargo door and over outboard side of skid.
- g. Groundperson 1:
  - (1) Step on side support of bucket frame on non-skid strip, forward side of bucket.
  - (2) Grab lifting strap.
  - (3) Open hook keeper assembly and insert cargo loop.

---

**WARNING**

---

Ensure that hook keeper snaps into locked position or PDU could fall during flight, pulling hand control assembly out of operator's hand. Injury to personnel could result.

- (4) Release hook keeper and step down.

**SLOW DOWN**

Arms down with palms toward ground, then moved up and down several times.

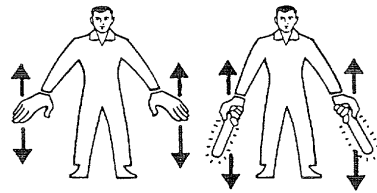

**HOVER**

Arms extended horizontally sideways, palms downward.

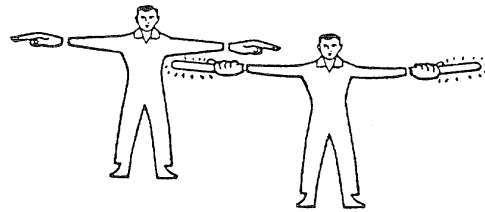

**SPOT TURN**

Left or right hand moving upward and backward, from a horizontal position, to indicate direction of tail movement. Other hand pointing to spot turns.

Marshaler must remain in full eye-view with pilot.

No ICAO signal.

No NATO signal.

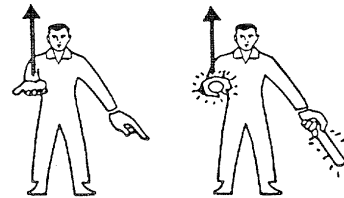
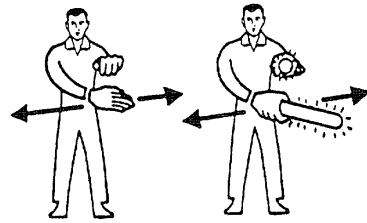

Figure 2-13. Hand Signals (Sheet 1 of 3)

**RELEASE LOAD**

Left arm extended forward horizontally, fist clenched, right hand making horizontal slicing movement below the left fist, palm facing body. No ICAO signal.



**LOAD HAS NOT BEEN RELEASED**

Bend left arm horizontally across chest, with fist clenched, palm downward; open right hand pointing up vertically to center of left fist.

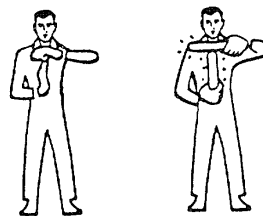

**VERTICAL MOVEMENT-MOVE UPWARD**

Arms extended horizontally sideways beckoning upwards, with palms turned up. Speed of movement indicates rate of ascent.

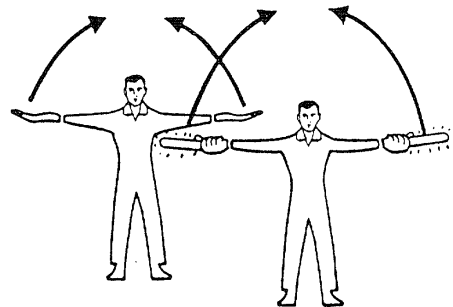
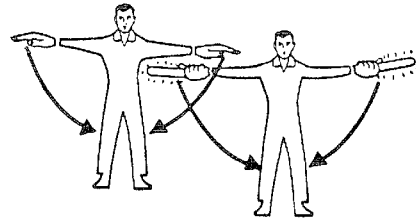

Figure 2-13. Hand Signals (Sheet 2 of 3)



**VERTICAL MOVEMENT-MOVE  
DOWNWARD**

Arms extended horizontally sideways beckoning downwards with palms turned down. Speed of movement indicates rate of descent.



**HORIZONTAL MOVEMENT-MOVE TO  
RIGHT (STARBOARD)**

Left arm extended horizontally sideways in direction of movement and other arm swung over the head in direction, in a repeating movement.

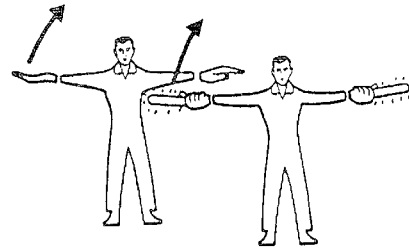

**HORIZONTAL MOVEMENT-MOVE TO  
LEFT (PORT)**

Right arm extended horizontally sideways in direction of movement and other arm swung over the head in direction, in a repeating movement.

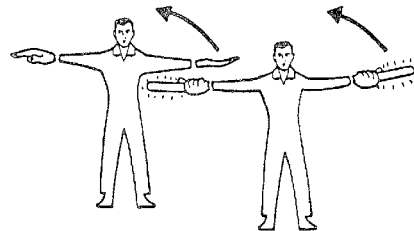

Figure 2-13. Hand Signals (Sheet 3 of 3)

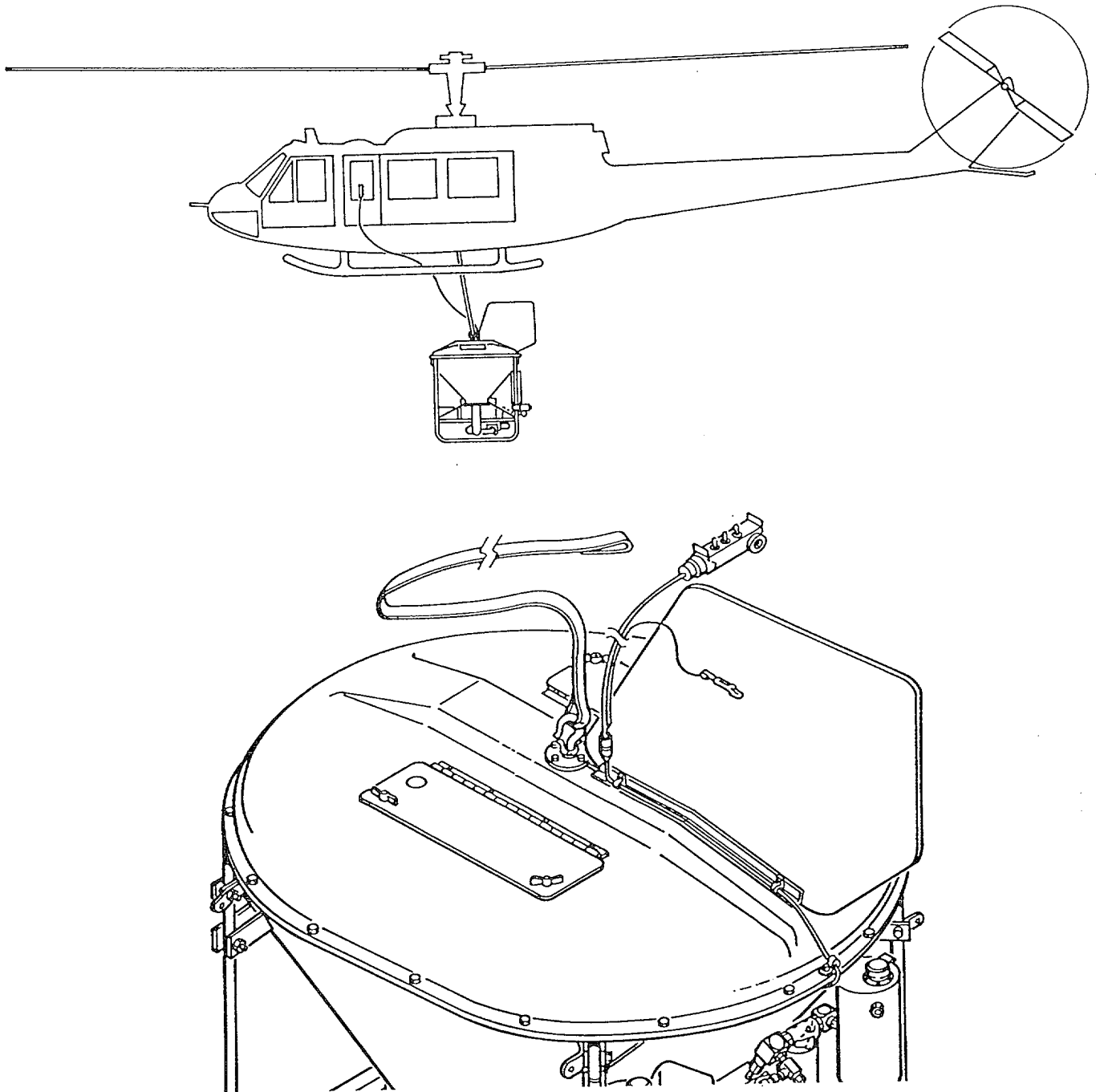

Figure 2-14. Helicopter/Lifting Strap Hookup

---

**WARNING**

---

Ground personnel must be aware of their position in relation to helicopter at all times to prevent personal injury. Ground personnel involved in ground operation of PDU and/or helicopter shall wear protective head gear for ears and eyes to prevent personal injury.

A hovering helicopter (in the air) will create static electricity which exposes personnel to an electrical shock hazard. To avoid electrical shock during the electrical hookup, the groundperson should hold the insulated wires and tap the metal connectors together. This will discharge the static electricity. Alternative methods are the use of a grounding rod and chain, a discharge wand, or touching the helicopter down just before hookup.

- (5) Attach hand control assembly cable to PDU wiring harness as shown in figure 2-14.

---

**WARNING**

---

Make sure hand control safety cable hook is fastened to a secure point inside helicopter (e.g., tie down ring). Failure to do so could result in injury or death to personnel.

- h. Operator: Attach hand control safety cable hook to a secure point inside helicopter.
- i. Groundperson 1: Move out from under helicopter and to right about 40-50 ft away.
- j. Helicopter Crew Chief and Groundperson 2:
  - (1) Make sure Groundperson 1 is clear.
  - (2) Direct pilot to take up slack on load.

## 2-12. FLYING PDU TO MISSION LOCATION

---

**WARNING**

---

Minimum forward speed of 25 knots is required to stabilize PDU in flight. Below 25 knots, PDU may rotate due to rotor wash. This increases risk of control cord separation at pull-away connector due to possible wrapping of control cord around lifting strap of PDU frame. Maximum speed of helicopter with PDU attached shall not exceed 90 knots (103.5 mph) at altitude of 50-100 ft. Failure to comply may result in injury to personnel or damage to equipment.

Groundperson 2 and Helicopter Crew Chief:

**WARNING**

Ground personnel must be aware of their position in relation to helicopter at all times to prevent personal injury. Ground personnel involved in ground operation of PDU and/or helicopter shall wear protective head gear for ears and eyes to prevent personal injury.

- a. Using appropriate hand signals (figure 2-13), signal helicopter pilot that area is clear for takeoff.
- b. Direct pilot in vertical liftoff until PDU clears ground.

**2-13. PDU OPERATION**

- a. Make sure SYSTEM switch is set to OFF.
- b. Set POWER switch to ON. Check that POWER indicator lights.
- c. Start engine with ENGINE START switch. Check that ENGINE indicator lights.

**NOTE**

Note time that dispersal begins and ends since application rate can only be determined if dispersal time is known.

- d. When ready to disperse pesticide, set SYSTEM switch to ON. Check that EMPTY indicator is not lit. Note time.

**CAUTION**

Shut down hydraulic system immediately when EMPTY indicator lights, or damage to pump could occur.

- e. When EMPTY indicator lights, set SYSTEM switch to OFF, ENGINE switch to OFF, and POWER switch to OFF. Note time.

---

**WARNING**

---

Personnel handling solid or liquid pesticides shall use appropriate personal protective equipment consisting of respirators, coveralls, rubber gloves, goggles, etc., as required by type of pesticide used and in accordance with manufacturer's label directions. Avoid direct contact with pesticide. Observe all warnings on label. Handle pesticide in well-ventilated area. Failure to do so could result in personal injury.

- f. If mission is not complete, land, refill bucket assembly, and repeat procedure. If mission is complete, perform cleanup procedures.

**2-14. LANDING PDU**

---

**WARNING**

---

Ground personnel must be aware of their position in relation to helicopter at all times to prevent personal injury. Ground personnel involved in ground operation of PDU and/or helicopter shall wear protective head gear for ears and eyes to prevent personal injury.

A hovering helicopter (in the air) will create static electricity which exposes personnel to an electrical shock hazard. To avoid electrical shock during the electrical hookup, the groundperson should hold the insulated wires and tap the metal connectors together. This will discharge the static electricity. Alternative methods are the use of a grounding rod and chain, a discharge wand, or touching the helicopter down just before hookup.

- a. Groundperson 2: Direct pilot to hover with PDU just above ground.

**CAUTION**

PDU shall not be released from helicopter until PDU is completely on ground, or PDU could be damaged.

- b. Groundperson 1: If required, swing PDU around to head it in forward direction before it reaches ground.
- c. Helicopter Crew Chief: Direct pilot downward from hovering position until PDU touches ground.

**CAUTION**

Groundperson 1 will ensure that terrain is flat enough that entire weight of PDU will be supported by the legs. Booms must not touch ground because they might bend or break.

- d. Groundperson 1: Disconnect hand control cable and release lifting strap.

**CAUTION**

Operator must carefully pull hand control assembly cable back into helicopter before it lands. If not done, skid of helicopter could land on and damage cable.

**NOTE**

When PDU's mission is complete, operator will release strap at helicopter cargo hook.

- e. Operator: Pull hand control assembly cable carefully back into helicopter.
- f. Helicopter pilot: Lift away from PDU and land nearby to disembark operator.
- g. Operator: Remove hand control and control cable from helicopter.

**2-15. POST-MISSION SERVICING**

**WARNING**

Personnel handling solid or liquid pesticides shall use appropriate personal protective equipment consisting of respirators, coveralls, rubber gloves, goggles, etc., as required by type of pesticide used and in accordance with manufacturer's label directions. Avoid direct contact with pesticide. Observe all warnings on label. Handle pesticide in well-ventilated area. Failure to do so could result in personal injury.

- a. **Draining LV and ULV System Booms.**

**CAUTION**

Make sure any fluid still in bucket is drained into container that contains same type fluid being used. Do not mix oil-base fluids with water-base fluids.

- (1) Ensure crosstube gate valve is open.
- (2) Place suitable container under ball valve.

- (3) Open ball valve and allow to drain.
- (4) When system is drained, close ball valve. Flush system in accordance with pesticide label directions. Use water if spray fluid was water-based; use mineral oil if spray fluid was oil-based.
- (5) Store or dispose of pesticide-filled containers in accordance with pesticide manufacturer's label directions.

**b. Draining SD System.**

- (1) Remove motor and slinger assembly from bucket assembly (para 4-51).
- (2) Place suitable container under both hoppers.
- (3) Start engine and turn system switch ON.
- (4) Press DISPERSAL pushbutton on hand control. Gates will open.
- (5) Continue to press DISPERSAL pushbutton until no pesticide falls into containers.

**WARNING**

Compressed air used for cleaning and drying purposes shall not exceed 30 psi. Use only with effective chip guarding and personal protective equipment (goggles/shield, gloves, etc). Flying debris could cause personal injury.

- (6) Open door on top of bucket. Using compressed air at less than 30 psi, blow pesticide residue down hoppers.
- (7) Press dispersal button again to empty remaining pesticide from hoppers.
- (8) Install motor and slinger assembly on bucket (para 4-51).
- (9) Store or dispose of pesticide-filled containers in accordance with manufacturer's label.

**2-16. PREPARATION FOR MOVEMENT**

**a. Disassembly of LV System.**

**NOTE**

Both LV boom assemblies are removed/disassembled the same way. This procedure is for the right LV boom.

- (1) Remove clamps (1, 2, and 3, figure 2-15) from boom. Pull back Kamlock ears and remove boom extension (4) from Connect Point 11.

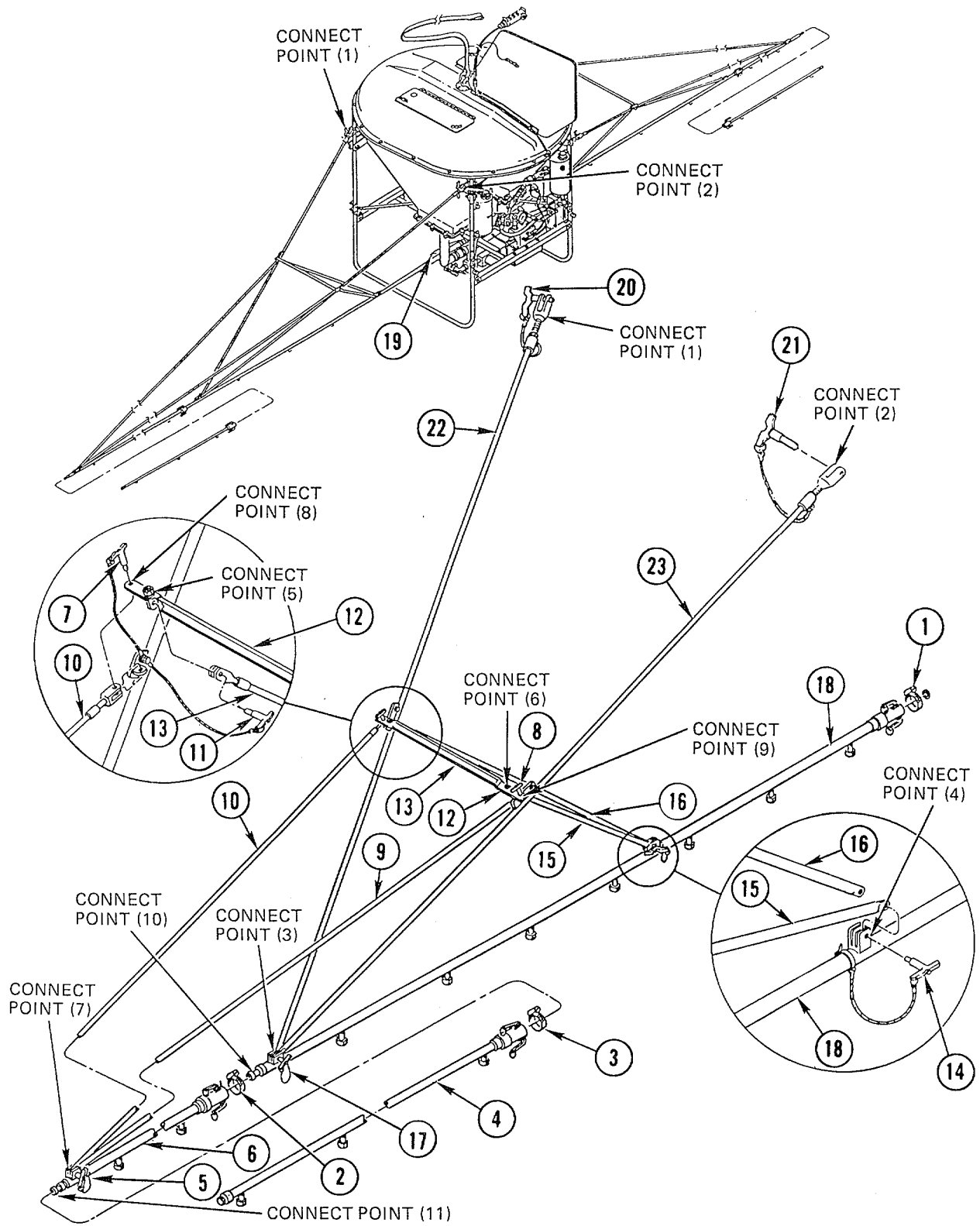

Figure 2-15. Disassembly of LV System



- (2) Remove quick-release pin (5) at Connect Point 7 by applying upward pressure to outboard boom weldment (6).
- (3) Pull back Kamlock ears and remove outboard boom weldment (6).
- (4) Remove two quick-release pins (7 and 8) at Connect Points 8 and 9. Remove two struts (9 and 10).
- (5) Remove two quick-release pins (11 and 12) at Connect Points 5 and 6. Remove strut (13).
- (6) Remove Kamlock-release pin (14) at Connect Point 4. Remove two struts (15 and 16).
- (7) Remove quick-release pin (17) at Connect Point 3.
- (8) Pull Kamlock ears back and remove outboard boom weldment (18) from center boom weldment (19) on pump and crosstube.
- (9) Remove two quick-release pins (20 and 21) at Connect Points 1 and 2. Remove two struts (22 and 23).
- (10) Clean and store booms in original containers.

**b. Disassembly of ULV System.**

- (1) Open crosstube gate valve (1, figure 2-16) and ball valve (2).
- (2) Disconnect hydraulic quick-disconnect fitting (3) from hydraulic filter elbow fitting.
- (3) Disconnect hydraulic quick-disconnect fitting (4) from hydraulic pump.
- (4) Remove clamps (5) from Kamlock ears on center boom.
- (5) Disconnect Kamlock hose ends (6 and 7) from center boom by opening Kamlock ears.
- (6) Remove ULV boom (8) from ULV attach points on bucket assembly by removing two quick-release pins (9 and 10).
- (7) Clean and store components in original containers.

**c. Disassembly of SD System.**

- (1) Spin slinger to ensure no loose or foreign objects are in slinger.
- (2) Disconnect left and right capacitive light switch wiring harnesses (1, figure 2-17) from each other. Disconnect left hopper assembly capacitive light switch wiring harness (2) from bucket wiring harness.
- (3) Remove and cap four hydraulic fittings (3) from two hopper cylinders (4).
- (4) Remove and cap two 1/4-in. hydraulic fittings (5 and 6) from back of secondary hydraulic manifold (7).

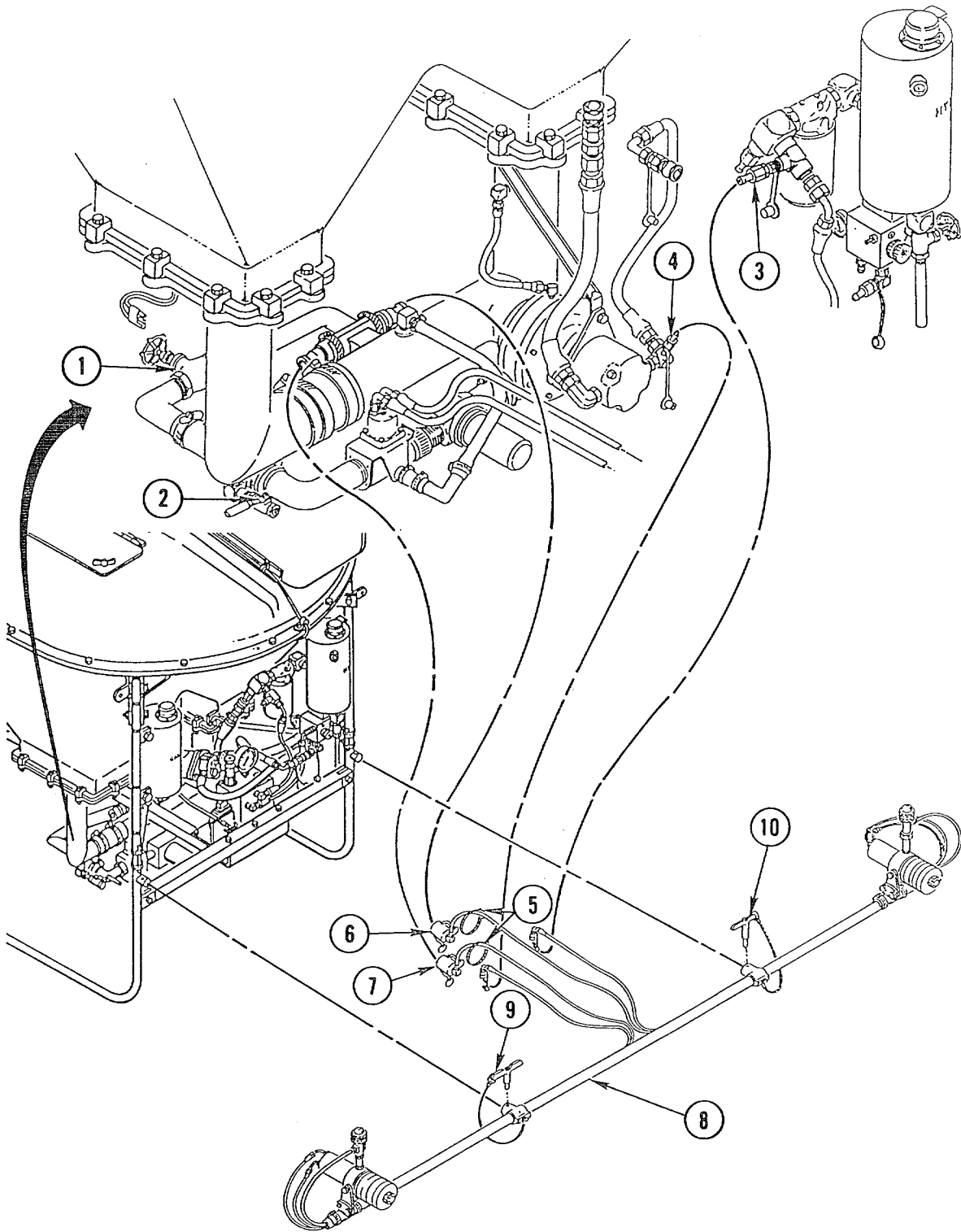

Figure 2-16. Disassembly of ULV System

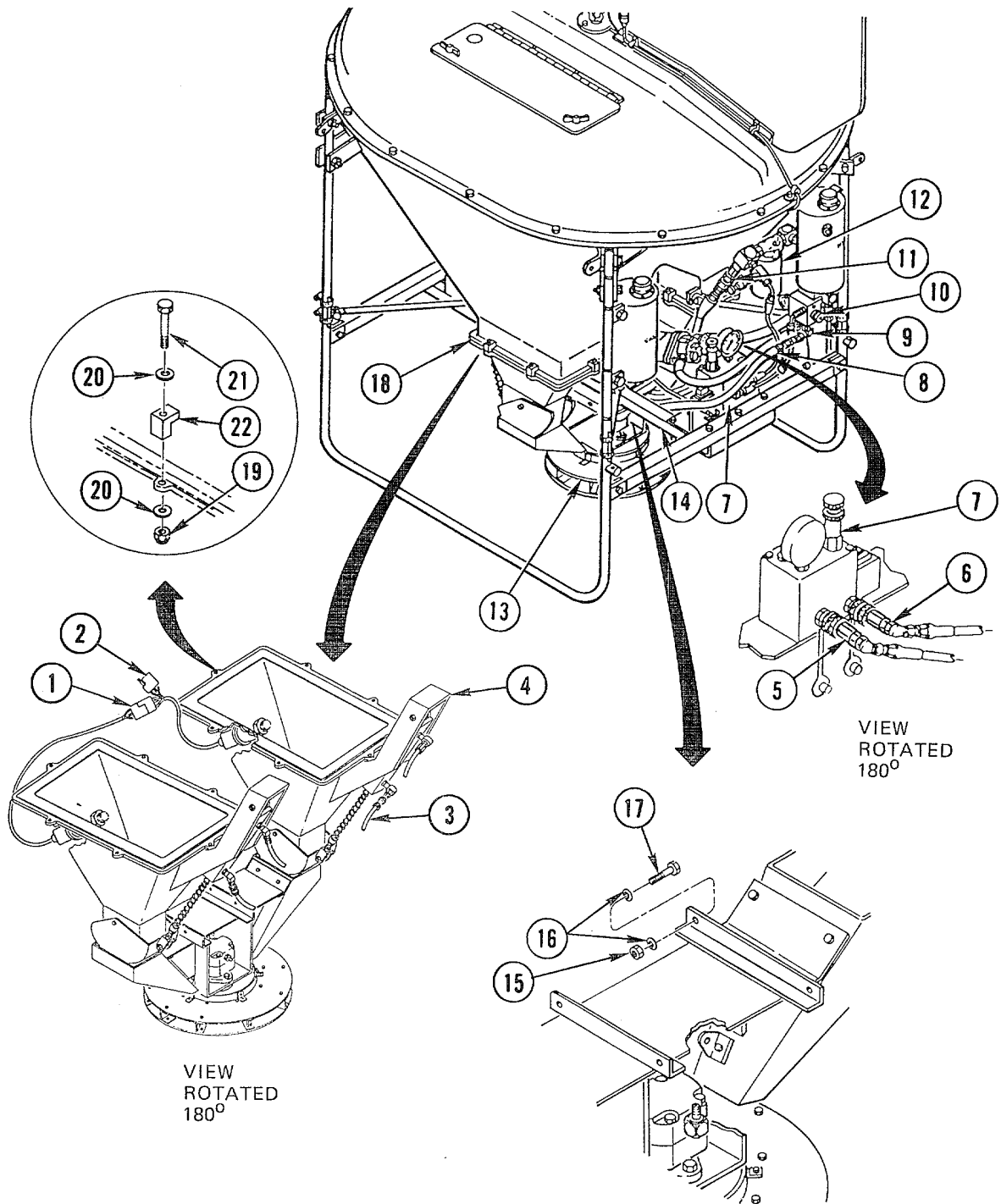

Figure 2-17. Disassembly of SD System

- (5) Remove and cap 1/2-in. hydraulic hose (8) from front, bottom quick-disconnect fitting (9) on primary hydraulic manifold (10).
- (6) Remove and cap 3/4-in. hose (11) from quick-disconnect fitting on back of hydraulic filter (12).

**NOTE**

Two people are required to remove motor and slinger assembly.

- (7) Remove motor and slinger assembly (13) from engine platform (14) by removing four nuts (15), eight washers (16), and four bolts (17).
- (8) Using appropriate clamping device, clamp to both left and right hopper assemblies (18).
- (9) Remove six nuts (19), six washers (20) six bolts (21), six washers (20), and six clips (22) from each hopper assembly.
- (10) While supporting hoppers, remove clamping device. Carefully lower and remove hopper assemblies.

**Section IV. OPERATION UNDER UNUSUAL CONDITIONS****2-17. OPERATION IN EXTREME HEAT**

The PDU can be operated in extreme heat observing the following precautions:

- a. Visually inspect cooling fins of engine for dust or foreign matter that might stop flow of air.
- b. Check oil level. Add oil as required.

**2-18. OPERATION IN DUSTY OR SANDY AREAS**

Sand and dust can seriously reduce the efficiency of the PDU, but it can be operated observing the following precautions:

- a. Service air cleaner daily to keep fuel system free of sand and dirt.
- b. Strain all fluids and fuel before adding to reservoirs.
- c. Using water, clean interior and exterior of bucket frequently.
- d. Check oil level. Add oil as required.

**2-19. OPERATION UNDER RAINY OR HUMID CONDITIONS**

The PDU is not designed to be operated in rainy or extremely humid conditions. Observe the following precautions during these conditions:

- a. If PDU is outside and not operating, cover with canvas or other waterproof material during damp, rainy weather. Remove cover during dry weather to allow PDU to dry.
- b. Keep fuel tank full at all times to prevent condensation.

**CAUTION**

Humid conditions can cause corrosion and deterioration of electrical components.

- c. Keep electrical components clean and dry.
- d. Check oil level. Add oil as required.

**2-20. OPERATION IN SALT WATER AREAS**

The PDU is not designed to be operated near salt water. Observe the following precautions:

- a. Keep PDU covered.
- b. Rinse exposed areas with clear water periodically to remove salt.

## **2-21. EMERGENCY OPERATION**

When an emergency condition occurs, position the POWER and SYSTEM ON/OFF switches to OFF. If an inflight emergency occurs, the PDU may be jettisoned at the pilot's discretion.

### **RECOMMENDATION TO HELICOPTER PILOT**

The pilot must be briefed not to arm the external cargo electrical release switch. A second switch, the cargo release off arm switch located on the miscellaneous panel, which arms the external cargo electrical release switch, should be monitored by the co-pilot during spray operations. If an emergency situation occurs, the external cargo electrical release switch should be armed or the PDU could be jettisoned using the external cargo mechanical release.

**CHAPTER 3  
OPERATOR MAINTENANCE INSTRUCTIONS**

	<b>Para</b>	<b>Page</b>
Lubrication .....	3-1	3-1
Troubleshooting Procedures .....	3-2	3-1

**Section I. LUBRICATION**

**3-1. LUBRICATION**

There are no components on the Pesticide Dispersal Unit, Multicapability, Helicopter Slung (PDU) that require lubrication. Check engine oil and hydraulic fluid in accordance with Table 2-4, Operator Level PMCS. Refer to Appendix E for appropriate fluids.

**Section II. TROUBLESHOOTING**

**3-2. TROUBLESHOOTING PROCEDURES**

The troubleshooting procedures listed in table 3-1 are those that may be done by operator level personnel. Problems that may arise during operation or maintenance of the PDU or its components are listed under Malfunction. Tests or Inspections to conduct and Corrective Actions to take to repair the malfunction follow. Perform the tests/inspections and corrective actions in the order listed.

This manual cannot list all malfunctions that may occur, nor all tests or inspections and corrective actions. If a malfunction is not listed or is not corrected by listed corrective actions, notify your supervisor.

**SYMPTOM INDEX**

<b>Symptom</b>	<b>Page</b>
1. ENGINE FAILS TO START/IS HARD TO START .....	3-2
2. ENGINE STARTS, BUT FAILS TO KEEP RUNNING.....	3-2
3. ENGINE EXHAUST SMOKEY .....	3-3
4. ENGINE SURGES OR OVERSPEEDS.....	3-3
5. ENGINE MISSES OR RUNS ERRATICALLY.....	3-3
6. ENGINE VIBRATES .....	3-3
7. SPRAY SYSTEM CONTROL VALVE DOES NOT OPEN WHEN DISPENSER BUTTON IS PRESSED.....	3-3
8. LOW VOLUME BOOM SYSTEM DOES NOT SPRAY .....	3-4

**SYMPTOM INDEX**

<b>Symptom</b>	<b>Page</b>
9. ULT.RA-LOW VOLUME BOOM SYSTEM DOES NOT SPRAY .....	3-4
10. SD SYSTEM SLINGER DOES NOT SPIN .....	3-4
11. SD SYSTEM CHUTES DO NOT OPEN .....	3-5

**Table 3-1. Operator Troubleshooting**

---

**Malfunction**

**Test or Inspection**

**Corrective Action**

---

**ENGINE AND PUMP ASSEMBLY**

**1. ENGINE FAILS TO START/IS HARD TO START.**

- Step 1. Check for insufficient fuel supply.
  - Add clean fuel (item 19, Appendix E).
- Step 2. Check for water in fuel.
  - Drain fuel and replace with clean fuel (item 19, Appendix E).
- Step 3. Check oil level.
  - Add engine oil (item 37, Appendix E) to full level.
- Step 4. Check battery terminals for corrosion or loose or defective cables.
  - Refer to unit maintenance.
- Step 5. Check for defective -and control unit.
  - Check to see if power indicator is on. If light is not on, check for blown fuse in key switchbox. If fuse is defective, refer to unit maintenance.

**2. ENGINE STARTS, BUT FAILS TO KEEP RUNNING.**

- Step 1. Check for dirty fuel..
  - Drain fuel and replace with clean fuel (item 19, Appendix E).
- Step 2. Check. -for water in fuel.
  - Drain fuel and replace with clean fuel (item 19, Appendix E).
- Step 3. Check for insufficient fuel supply.
  - Adjust throttle out slightly to increase gas flow.



Table 3-1. Operator Troubleshooting (Cont)

**Malfunction****Test or Inspection****Corrective Action**

- Step 4. Check that power indicator on hand control unit is on.
- If not on, refer to unit maintenance.
- Step 5. Check engine cooling fins and blower housing for dirt or debris.

**WARNING**

Compressed air used for cleaning and drying purposes shall not exceed 30 psi. Use only with effective chip guarding and personal protective equipment (goggles/shield, gloves, etc.). Flying debris could cause personal injury.

- Using compressed air, clean fins and blower housing, or wash with water and use compressed air to dry.

3. ENGINE EXHAUST SMOKEY.
  - Refer to unit maintenance.
4. ENGINE SURGES OR OVERSPEEDS.
  - Refer to unit maintenance.
5. ENGINE MISSES OR RUNS ERRATICALLY.
  - Refer to unit maintenance.
6. ENGINE VIBRATES.

Check for loose engine and pump assembly isolators or mounting plate.

- Refer to unit maintenance.

## BUCKET AND CROSSTUBE ASSEMBLY

7. SPRAY SYSTEM CONTROL VALVE DOES NOT OPEN WHEN DISPENSER BUTTON IS PRESSED.

Check for loose connection at control valve coil.

- Secure connection. If problem still exists, refer to unit maintenance.

Table 3-1. Operator Troubleshooting (Cont)

**Malfunction****Test or Inspection****Corrective Action**

## LV SYSTEM

## 8. LOW VOLUME BOOM SYSTEM DOES NOT SPRAY.

- Step 1. Check that EMPTY bucket indicator light is on.
- If light is on, do not operate. Turn system OFF.
  - Refill bucket.
- Step 2. Check primary manifold pressure for correct adjustment.
- Adjust pressure (para 2-10).
- Step 3. Check for clogged crosstube strainer or damaged spray nozzles.
- Refer to unit maintenance.

## ULV SYSTEM

## 9. ULTRA-LOW VOLUME BOOM SYSTEM DOES NOT SPRAY.

- Step 1. Check that EMPTY bucket indicator light is on.
- If light is on, do not operate. Turn system OFF.
  - Refill bucket.
- Step 2. Check primary manifold pressure for correct adjustment.
- Adjust pressure (para 2-10).
- Step 3. Check for clogged or damaged rotary atomizer.
- Refer to unit maintenance.

## SD SYSTEM

## 10. SD SYSTEM SLINGER DOES NOT SPIN.

- Step 1. Check hoppers/chutes for correct adjustment.
- Adjust hopper/chute alignment (para 2-9).
- Step 2. Check primary manifold pressure for correct adjustment.
- Adjust pressure (para 2-10).

**Table 3-1. Operator Troubleshooting (Cont)**

---

**Malfunction****Test or Inspection****Corrective Action**

---

## 11. SD SYSTEM CHUTES DO NOT OPEN.

- Step 1. Check hydraulic lines to ensure connection to chute cylinders.
- Connect hydraulic quick disconnects.
- Step 2. Check for chute alignment.
- Adjust chute alignment (para 2-9).
-

**CHAPTER 4**  
**UNIT MAINTENANCE INSTRUCTIONS**

	<b>Para</b>	<b>Page</b>
Air Cleaner Replacement/Repair .....	4-22	4-45
All Angle Isolator Replacement .....	4-30	4-71
Battery Assembly Replacement.....	4-33	4-78
Battery Cable Replacement.....	4-31	4-72
Battery/Hydraulic Assembly Replacement.....	4-29	4-68
Bucket Assembly Replacement.....	4-13	4-18
Bucket Harness Replacement .....	4-37	4-93
Carburetor Replacement/Repair.....	4-21	4-39
Checking Unpacked Equipment .....	4-5	4-2
Common Tools and Equipment.....	4-1	4-2
Dolly Assembly Repair.....	4-56	4-160
Dolly Assembly Replacement.....	4-55	4-158
Door Lid Assembly Repair.....	4-15	4-23
Door Lid Assembly Replacement .....	4-14	4-22
Engine and Pump Assembly Replacement.....	4-19	4-29
Engine and Pump Assembly Testing .....	4-18	4-27
Gas Tank Assembly Replacement/Repair .....	4-28	4-64
General.....	4-6	4-3
Hand Control Assembly/Electrical-Safety Cable Assembly Replacement.....	4-38	4-98
Hopper Assembly Repair.....	4-54	4-154
Hopper Assembly Replacement .....	4-53	4-150
Hydraulic Pump Assembly Replacement.....	4-27	4-60
Hydraulic Reservoir Primary Manifold Assembly Repair.....	4-35	4-85
Hydraulic Reservoir Primary Manifold Assembly Replacement.....	4-34	4-82
Introduction .....	4-12	4-17
Key Switchbox Assembly Replacement.....	4-20	4-34
Leakage Definitions.....	4-9	4-3
LV Boom Assembly Replacement/Repair.....	4-46	4-123
Maintenance Forms and Records .....	4-7	4-3
Motor and Slinger Assembly Repair .....	4-52	4-146
Motor and Slinger Assembly Replacement.....	4-51	4-142
Muffler Assembly Repair.....	4-24	4-51
Muffler Assembly Replacement.....	4-23	4-50
Oil Fill and Drain Assembly Repair.....	4-26	4-56
PMCS Table .....	4-10	4-4
Preparation for Storage or Shipment.....	4-57	4-161
Primary Hydraulic Manifold Assembly Replacement.....	4-36	4-90
Procedures.....	4-8	4-3
Procedures.....	4-8	4-3
Pump and Crosstube Assembly Chemical Pump Replacement .....	4-43	4-116
Pump and Crosstube Assembly Hydraulic Motor and Chemical Pump Assembly Replacement .....	4-42	4-114
Pump and Crosstube Assembly Hydraulic Motor Replacement.....	4-44	4-118
Pump and Crosstube Assembly Level Switch Replacement .....	4-40	4-106
Pump and Crosstube Assembly Repair .....	4-41	4-109
Pump and Crosstube Assembly Replacement.....	4-39	4-101
Pump and Crosstube Assembly Spray System Control Replacement.....	4-45	4-120
Repair Parts.....	4-3	4-2

	<b>Para</b>	<b>Page</b>
Rotary Atomizer Assembly Repair.....	4-50	4-137
Secondary Hydraulic Manifold Assembly Replacement.....	4-32	4-76
Sling Hook Assembly Replacement.....	4-17	4-25
Spark Plug Replacement.....	4-25	4-54
Special Instructions for Administrative Storage.....	4-58	4-161
Special Tools, TMDE, and Support Equipment.....	4-2	4-2
Spray Nozzle Replacement/Repair.....	4-47	4-128
Tail Fin Replacement.....	4-16	4-24
Troubleshooting Procedures.....	4-11	4-9
ULV Boom Assembly Repair.....	4-49	4-134
ULV Boom Assembly Replacement.....	4-48	4-130
Unpacking.....	4-4	4-2

**Section I. REPAIR PARTS, SPECIAL TOOLS; TEST, MEASUREMENT,  
AND DIAGNOSTIC EQUIPMENT (TMDE); AND  
SUPPORT EQUIPMENT**

**4-1. COMMON TOOLS AND EQUIPMENT**

For authorized common tools and equipment, refer to the Modified Table of Organization and Equipment (MTOE) at your unit.

**4-2. SPECIAL TOOLS, TMDE, AND SUPPORT EQUIPMENT**

Special tools required for unit maintenance are listed in the Maintenance Allocation Chart (Appendix B) and the Repair Parts and Special Tools List (Appendix F).

**4-3. REPAIR PARTS**

Repair parts for the Pesticide Dispersal Unit, Multicapability, Helicopter Slung (PDU) are listed and illustrated in the Repair Parts and Special Tools List (Appendix F).

**Section II. SERVICE UPON RECEIPT**

**4-4. UNPACKING**

The PDU is shipped partially assembled in reusable shipping containers. Carefully remove the PDU and accessories from shipping containers and packing materials. Save shipping containers for storage and reshipment.

**4-5. CHECKING UNPACKED EQUIPMENT**

- a. Inspect equipment for damage incurred during shipment. If equipment has been damaged, report damage on SF 364, Report of Discrepancy.
- b. Check equipment against packing slip to see if shipment is complete. Report all discrepancies in accordance with instructions in DA Pam 738-750.

### Section III. UNIT PREVENTIVE MAINTENANCE CHECKS AND SERVICES (PMCS)

#### 4-6. GENERAL

This section details the Preventive Maintenance Checks and Services (PMCS) required for the PDU. PMCS is a scheduled, step-by-step inspection and service of the PDU and PDU components. Its purpose is to keep the PDU in good condition, and to identify and correct problems before costly and time-consuming repairs are needed.

Unit PMCS should be performed at the intervals shown below:

- a. Do your (M) preventive maintenance monthly (every month).
- b. Do your (S) preventive maintenance semiannually (every 6 months).
- c. Do your (A) preventive maintenance annually (once every year).

#### 4-7. MAINTENANCE FORMS AND RECORDS

Use DA Form 2404, Equipment Inspection and Maintenance Worksheet, to record periodic maintenance services performed and faults corrected. The item number on the DA Form 2404 must be the same as the item number of the PMCS. For information on maintenance forms and records, see DA Pam 738-750.

#### 4-8. PROCEDURES

Nuts, bolts, and screws: When torquing bolts or nuts, begin with larger-diameter or inner bolt first and tighten to the specified torque diagonally, unless a particular sequence is specified. After reassembly, check all parts for proper installation and operation.

#### 4-9. LEAKAGE DEFINITIONS

#### NOTE

Class III leaks are cause to remove equipment from service until repair action is taken.

Class I Seepage of fluid (as indicated by wetness or discoloration) not great enough to form drops.

Class II Leakage of fluid great enough to form drops but not enough to cause drops to drip from item being checked/inspected.

Class III Leakage of fluid great enough to form drops that fall from item being checked/ inspected.

4-10. PMCS TABLE

Table 4-1. Unit Level PMCS

NOTE: Within designated interval, these checks are to be performed in the order listed.

ITEM NO.	M-Monthly			ITEM TO BE INSPECTED	PROCEDURE
	INTERVAL				
	M	S	A		
1	•			Battery	Check for charge. Replace as necessary. Check terminals for corrosion. Clean as necessary. Check battery for cracks and leaks. Ensure cables are tight. Tighten as necessary. Check battery box for damage. Check cables for damage. Replace as necessary.
2	•			Bucket	Check all mounting hardware for looseness. Tighten as required. All locknuts may only be tightened once and are not to be reinstalled.
3	•			Hand Control	Check harness connection nut at bottom of hand control for looseness. Tighten as required. Check heat shrink material for deterioration. Refer to direct support maintenance. Check switch mounting nuts for tightness. Tighten as required. Check hand control for obvious damage. Replace as necessary (para 4-38). Check indicators and switches for operation. Replace hand control (para 4-38).
4	•			Key Switchbox	Check box for security in mounting. Tighten as required. Check for obvious external damage. Check fuse in key switch panel. If fuse is faulty, replace.
5	•			Hydraulic Reservoir and Fuel Tank	Check mounting hardware for security. Tighten as required. Check mounting tabs on frame for cracks at welded seams and mounting holes for elongation. Refer to direct support maintenance. Check hydraulic reservoir sight gage for damage. Replace reservoir (para 4-34). Check fuel tank sediment bowl for damage. Replace bowl (para 4-28).

4-10. PMCS TABLE

Table 4-1. Unit Level PMCS (Cont)

NOTE: Within designated interval, these checks are to be performed in the order listed.

ITEM NO.	M-Monthly			ITEM TO BE INSPECTED	PROCEDURE
	INTERVAL				
	M	S	A		
6	•			Primary Hydraulic Manifold	Check manifold for Class III hydraulic leaks at fittings. Replace as required (para 4-36.) Check manifold for security in mounting. Tighten as required. Check liquid-filled pressure gage for leaks. Replace as required (para 4-36).
7	•			Secondary Hydraulic Manifold	Check manifold for Class III hydraulic leaks at fittings. Replace as required (para 4-32). Check manifold for security in mounting. Tighten as required. Check liquid-filled pressure gage for leaks. Replace as required (para 4-32).
8	•			Hydraulic Lines	Check all hydraulic lines to ensure fittings are tight and not leaking. Tighten as required. Check for severely chafed or rubbed spots that would lead to failure. Replace lines (para 4-32 and 4-34).
9	•			Engine	Check engine for security in mounting to frame. Tighten as required. Check cooling fins for cracks or breaks. Check air cleaner for security and damage. Tighten or replace as necessary. Check hydraulic pump for Class III leaks and mounting bolts for tightness. Replace pump (para 4-27) and tighten bolts and hoses. Check for obvious external damage. Check all engine-mounted accessories and components for security and obvious damage. Tighten or replace as required. Check engine oil level. Fill as required.
10	•			Starter Motor	Check starter motor mounting bolts for tightness. Tighten as required. Check electrical lead attach points for tightness. Tighten as required.
11	•			Carburetor	Check hoses and gaskets for leaks. Replace as necessary. Check for free movement of choke assembly and linkage. Replace as necessary (para 4-21).



4-10. PMCS TABLE

Table 4-1. Unit Level PMCS (Cont)

NOTE: Within designated interval, these checks are to be performed in the order listed.

ITEM NO.	M-Monthly			ITEM TO BE INSPECTED	PROCEDURE
	INTERVAL				
	M	S	A		
12	•			Spark Plug	Remove spark plug and check insulator for cracks or chips. Replace as necessary (para 4-25). Check center electrode for square edges and side electrode for erosion. Replace as necessary (para 4-25). Check electrode gap to be within 0.039-0.043 in. Adjust gap as required. Check sealing washer for damage. Replace plug as required (para 4-25).
13	•			Oil Fill and Drain Assembly	Check oil level switch when engine oil is changed. With engine running, disconnect yellow and green leads from oil level switch. Connect leads from key switchbox together. Engine oil level light should flash and engine should stop. With engine stopped, disconnect key switchbox leads and check continuity between oil switch yellow and green leads. There should be no continuity. With leads disconnected, drain oil and check continuity between oil switch yellow and green leads. There should be continuity. Refill crankcase with SAE 10W-40 oil (item 40, Appendix E). If oil level switch is defective, replace engine (para 4-19).
14	•			Pump and Crosstube Assembly	Check crosstube-to-bucket mating flange bolts for tightness. Tighten as required. Check crosstube for obvious external damage. Replace as required (para 4-39). Check hydraulic motor mounting bolts for security. Tighten as required. Check dispersal pump mounting bolts for security. Tighten as required. Check spray system control unit for Class III leaks and security in mounting. Replace (para 4-45) or tighten as required. Check all hydraulic fittings for Class III leaks and hoses for exterior damage. Repair leaks and replace hoses as required.

4-10. PMCS TABLE

Table 4-1. Unit Level PMCS (Cont)

NOTE: Within designated interval, these checks are to be performed in the order listed.

ITEM NO.	M-Monthly			ITEM TO BE INSPECTED	PROCEDURE
	INTERVAL				
	M	S	A		
15	•			LV Boom and Nozzles	<p>Check boom assembly (both sides) for obvious exterior damage such as nicks, dents, or cracks. Replace as required (para 4-46).</p> <p>Check plastic nozzles for cross threading, nozzle ends for obstruction. Replace or clean nozzles (para 4-47).</p> <p>Ensure spraying disc and core seal are properly installed in quickjet cap.</p> <p>Ensure quickjet cap is screwed on securely to nozzle body. Secure cap.</p> <p>Check for missing or damaged quick-release pins. Replace as required (para 4-46).</p> <p>Check quick-release pin mount holes for elongation. Replace boom as required (para 4-46).</p>
16	•			ULV Boom and Rotary Atomizers	<p>Check boom assembly for external damage such as nicks, dents, or cracks. Replace as required (para 4-48).</p> <p>Check rotary atomizers for freedom of rotation and obstruction. Clean or replace as required (para 4-50).</p> <p>Check hydraulic fittings for Class III leaks and hoses for damage. Repair leaks or replace hoses as required (para 4-48).</p> <p>Check attaching hardware such as clamps and pins for damage and security. Replace as required (para 4-48).</p>
17	•			Hopper Assembly	<p>Check left and right hopper assemblies for exterior damage such as dents or cracks. Replace as required (para 4-53).</p> <p>Check capacitive light switch and harness for proper installation, damage, and security. Replace (para 4-54) or tighten as necessary.</p> <p>Check hydraulic cylinders and fittings for Class III leaks. Repair leaks at fittings or replace cylinder (para 4-54).</p> <p>Check chutes for foreign objects. Clean as required.</p>

4-10. PMCS TABLE

Table 4-1. Unit Level PMCS (Cont)

NOTE: Within designated interval, these checks are to be performed in the order listed.

ITEM NO.	M-Monthly			S-Semiannually	A-Annually	PROCEDURE
	INTERVAL					
	M	S	A			
18	•			Motor and Slinger Assembly		Check hydraulic motor for security in mounting. Tighten as required. Check hydraulic fittings for Class III leaks. Repair leaks. Check slinger for abrasive wear or possible splits in material. Repair/replace as required (para 4-52). Check slinger assembly for damage, corrosion, freedom of movement, or foreign objects. Replace (para 4-51) or clean as required. Check chutes for damage or missing hardware. Replace as required (para 4-52).
19	•			Dolly Assembly		Check dolly frame for damage such as bends or breaks. Replace as required (para 4-55). Check lock/release levers for worn areas or deterioration. Replace as required (para 4-55). Check dolly weldment for cracks. Replace as required (para 4-55). Check dolly swivel casters for freedom of operation and otherwise good condition. Repair/replace as required (para 4-56/4-55). Check mounting hardware for looseness. Tighten as required.

**Section IV. TROUBLESHOOTING**

**4-11. TROUBLESHOOTING PROCEDURES**

The troubleshooting procedures listed in table 4-2 are those that may be done by unit level personnel. Problems that may arise during operation or maintenance of the PDU or its components are listed under Malfunction. Tests or Inspections to conduct and Corrective Actions to take to repair the malfunction follow. Perform the tests/inspections and corrective actions in the order listed.

This manual cannot list all malfunctions that may occur, nor all tests or inspections and corrective actions. If a malfunction is not listed or is not corrected by listed corrective actions, notify your supervisor.

**SYMPTOM INDEX**

<b>Symptom</b>	<b>Page</b>
1. ENGINE FAILS TO START.....	4-10
2. ENGINE IS HARD TO START .....	4-11
3. ENGINE STARTS, BUT FAILS TO KEEP RUNNING.....	4-12
4. ENGINE OVERHEATS .....	4-12
5. ENGINE EXHAUST SMOKEY.....	4-13
6. ENGINE SURGES OR OVERSPEEDS.....	4-13
7. ENGINE MISSES OR RUNS ERRATICALLY.....	4-13
8. ENGINE VIBRATES.....	4-13
9. SPRAY SYSTEM CONTROL VALVE DOES NOT OPEN.....	4-13
10. NO SPRAY FROM NOZZLES.....	4-14
11. ROTARY ATOMIZERS DO NOT ROTATE .....	4-14
12. ROTARY ATOMIZERS DO NOT PRODUCE SPRAY .....	4-15
13. SLINGER DOES NOT ROTATE .....	4-15
14. CHUTE ASSEMBLY DOES NOT OPEN .....	4-16

Table 4-2. Unit Troubleshooting

## Malfunction

## Test or Inspection

## Corrective Action

## ENGINE AND PUMP ASSEMBLY

## 1. ENGINE FAILS TO START.

- Step 1. Check for partially discharged battery.
- Replace (para 4-31).
- Step 2. Check electrical system wiring.
- Check electrical system for tight connections and frayed or defective wiring. Tighten loose connectors. If wiring is defective, replace as required (para 4-37).
- Step 3. Check for defective key switchbox.
- Check fuse and replace if blown.
  - Check for disconnected wires behind key switchbox.
  - Check oil level switch:
  - Check continuity between oil level switch yellow and green leads. If there is continuity, oil level switch is faulty. Replace engine (para 4-19).  
If no continuity between yellow and green leads, check ignition system.
  - Check that battery cables are securely connected and free of corrosion. Tighten or clean cables (para 1-16) or replace cables (para 4-31).
- Step 4. Test ignition system.
- Test spark plug:  
Remove spark plug, attach it to spark plug cap, and ground side electrode against cylinder head cover. Turn on engine switch, pull recoil starter, and check to see if sparks jump across electrodes.
  - If no spark, set gap on new spark plug to 0.039 in. Attach spark plug cap to new spark plug and recheck. If spark is present, install new spark plug.
  - If no spark is present, disconnect wire A2 from engine switch and check for spark. If spark is present, replace engine switch.
  - If still no sparks, replace engine (para 4-19).

Table 4-2. Unit Troubleshooting

**Malfunction****Test or Inspection****Corrective Action**

## 2. ENGINE IS HARD TO START.

## Step 1. Check fuel supply.

- Check fuel tank and fill with fuel (item 19, Appendix E).
- Check that fuel valve is completely open. Open fuel valve. Restart.

## Step 2. Remove spark plug and inspect electrodes.

**WARNING**

Death or serious injury could result by repeated and/or prolonged breathing and/or skin contact of drycleaning solvent (PD-680). Use in a well-ventilated area. Do not use near open flame or in excessive heat. The flash point of this solvent is 100°F-183°F (38°C-59°C).

- If spark plug is dry, check for blockage of fuel tube and screen:  
Turn off fuel valve and remove sediment cup. Clean sediment cup and screen with drycleaning solvent (item 59, Appendix E).
- If spark plug is wet, check vacuum tube for vacuum. If no vacuum, replace vacuum tube and dashpot check valve (para 4-21).

## Step 3. Check for partially discharged battery.

- Replace battery (para 4-33).

## Step 4. Check for defective hand control unit.

- Replace hand control unit (para 4-38).

## Step 5. Check for defective battery cables or corroded terminals.

- Clean and make sure battery cables are securely connected and corrosion free.
- Replace cables if defective (para 4-31).

## Step 6. Check for defective spark plug.

- Remove and replace spark plug (para 4-25). Set gap to 0.039 in.

Table 4-2. Unit Troubleshooting

**Malfunction****Test or Inspection****Corrective Action**

- 
- Step 7. Check for faulty carburetor.
- Adjust:  
Start engine and allow to warm up to normal operating temperature. With engine idling, turn pilot screw in or out to setting that produces highest idle rpm. Correct setting will usually be obtained at approximately 2-1/4 turns out from fully closed (slightly seated) position. After pilot screw is correctly adjusted, turn throttle stop screw to obtain standard idle speed of 1400  $\pm$ 150 rpm.
  - Adjust governor control rod:  
Loosen nut on governor arm pinch bolt and move governor arm shaft as far as it will go (in same direction governor arm moves) up to open throttle. Start engine and allow to warm up to normal operating temperature. Move throttle lever to run engine at standard maximum speed of 3600 rpm.
  - Adjust throttle lever limiting screw so throttle lever cannot be moved past that point.
  - If conditions still exist, replace carburetor (para 4-21).

## 3. ENGINE STARTS, BUT FAILS TO KEEP RUNNING.

- Step 1. Check for insufficient fuel supply.
- Add clean fuel (item 19, Appendix E).
- Step 2. Check for water in fuel or dirty fuel.
- Drain fuel and replace with clean fuel (item 19, Appendix E).
- Step 3. Check for defective spark plug.
- Remove and replace spark plug (para 4-25). Set gap to 0.039 in.
- Step d4. Check for defective hand control.
- Replace hand control (para 4-38).
- Step 5. Check for faulty carburetor.
- Refer to Malfunction 2, step 7.
  - Repair or replace (para 4-21).

## 4. ENGINE OVERHEATS.

Check ,for dirty cooling fins and blower housing.

**Table 4-2. Unit Troubleshooting**

---

**Malfunction**

**Test or Inspection**

**Corrective Action**

---

5. ENGINE EXHAUST SMOKEY.

- Step 1. Check for too much oil in engine.
  - Drain excess oil from engine.
- Step 2. Check for improperly adjusted carburetor.
  - Refer to Malfunction 2, step 7.

6. ENGINE SURGES OR OVERSPEEDS.

- Step 1. Check for improperly adjusted carburetor.
  - Refer to Malfunction 2, step 7.
- Step 2. Check for improperly adjusted governor control rod.
  - Refer to Malfunction 2, step 7.

7. ENGINE MISSES OR RUNS ERRATICALLY.

- Step 1. Check for water in fuel system.
  - Drain fuel and refill tank with clean fuel (item 19, Appendix E).
- Step 2. Check for defective spark plug.
  - Replace (para 4-25).

8. ENGINE VIBRATES.

- Step 1. Check for loose engine and pump assembly mounting hardware.
  - Tighten and adjust all hardware.
- Step 2. Check for worn drive shaft coupling and star.
  - Replace drive shaft coupling and star (para 4-27).

BUCKET/CROSSTUBE ASSEMBLY

9. SPRAY SYSTEM CONTROL VALVE DOES NOT OPEN.

- Step 1. Check for loose harness connection.
  - Tighten.
- Step 2. Check for defective wires in harness.
  - Replace (para 4-37).
- Step 3. Check for defective hand control unit.
  - Replace hand control unit (para 4-38).



**Table 4-2. Unit Troubleshooting**

**Malfunction**

**Test or Inspection**

**Corrective Action**

- Step 4. Check for continuity at secondary manifold solenoid for 4- 10 ohms.
- If 4-10 ohms is not present, replace secondary manifold (para 4-32).
  - If 4-10 ohms is present, replace spray system control valve (para 4-45).

LV SYSTEM

10. NO SPRAY FROM NOZZLES.

- Step 1. Check for clogged strainer.  
Remove and clean strainer.
- Step 2. Check for leaking hoses.
- Replace hoses and hose clamps (para 4-46).
- Step 3. Check for defective spray nozzle.
- Repair or replace (para 4-46).
- Step 4. Check for defective LV boom assembly.
- Repair or replace (para 4-46).
- Step 5. Check for chemical pump operation.
- Check for air in chemical pump. Remove hose at top of volute and check for liquid. If liquid is not present, run chemical motor until liquid is present. Check chemical motor bleed line hose for foreign material. Clean or replace (para 4-40).
- Step 6. Check spray system control valve for operation.
- Refer to Malfunction 9.

ULV SYSTEM

11. ROTARY ATOMIZERS DO NOT ROTATE.

- Step 1. Check for leaking hoses.
- Replace hoses and hose clamps (para 4-49).
- Step 2. Check for defective hand control unit.
- Replace (para 4-38).

**Table 4-2. Unit Troubleshooting**

**Malfunction**

**Test or Inspection**

**Corrective Action**

- Step 3. Check for defective rotary atomizers.
  - Replace (para 4-50).

**12. ROTARY ATOMIZERS DO NOT PRODUCE SPRAY.**

- Step 1. Check primary hydraulic manifold for correct pressure.
  - Adjust pressure (para 2-10).
- Step 2. Check for defective quick disconnect.
  - Replace (para 4-50).
- Step 3. Check for plugged filter.
  - Replace (para 4-50).
- Step 4. Check for plugged spray head.
  - Remove sleeve assembly from spray head and soak in suitable solvent. Flush solvent and dissolved chemicals from assembly. Sleeve assemblies may be spun dry by reassembling on spray head and rotating for at least 30 seconds without introducing chemicals.
- Step 5. Check for defective rotary atomizers.
  - Replace (para 4-50).
- Step 6. Check for chemical pump operation.
  - Refer to Malfunction 10, step 5.
- Step 7. Check spray system control valve for operation.
  - Refer to Malfunction 9.

**SD SYSTEM**

**13. SLINGER DOES NOT ROTATE.**

- Step 1. Check for jammed or otherwise defective slinger pump.
  - Replace (para 4-52).
- Step 2. Check hydraulic pressure to pump.
  - Adjust primary manifold pressure to 900-1200 psi.

**Table 4-2. Unit Troubleshooting**

---

**Malfunction**

**Test or Inspection**

**Corrective Action**

---

- Step 3. Check for Class III leak at hose ends or fittings.
  - Tighten.
- Step 4. Check for damaged hand control switches.
  - Replace (para 4-38). If problem still exists, refer to direct support maintenance.

**14. CHUTE ASSEMBLY DOES NOT OPEN.**

- Step 1. Check for Class III leak at hose ends or fittings.
  - Tighten.
- Step 2. Check for foreign material trapped in chute.
  - Remove foreign material and clean chute.
- Step 3. Check for missing spacers between chute and hopper.
  - Replace spacers (para 4-54).
- Step 4. Check hydraulic pressure from secondary hydraulic manifold.
  - Adjust secondary hydraulic manifold to 300 psi. If problem still exists, refer to direct support maintenance.
- Step 5. Check for faulty secondary hydraulic manifold solenoid.
  - With multimeter set to ohms scale, measure resistance between solenoid terminals. Reading should be 8-9 ohms. If reading is less than 8-9 ohms, replace solenoid (para 4-32).

## Section V. UNIT MAINTENANCE PROCEDURES

### 4-12. INTRODUCTION

Unit maintenance is limited to removal and replacement of worn or damaged components as described in the procedures that follow.

Refer to paragraphs 1-15 through 1-20 for general maintenance instructions.

**4-13. BUCKET ASSEMBLY REPLACEMENT**

---

This task covers: Removal Installation

---

**A. INITIAL SETUP**

**Tools and Special Equipment:**

Tool Kit, 5180-00-177-7033

**Equipment Condition:**

Reference	Condition Description
Paragraph 4-39	Pump and Crosstube Assembly Removed
Paragraph 4-51	Motor and Slinger Assembly Removed
Paragraph 4-53	Hopper Assembly Removed
Paragraph 4-16	Tail Fin Removed
Paragraph 4-34	Hydraulic Reservoir Removed
Paragraph 4-28	Gas Tank Removed

---

**B. REMOVAL**

- (1) Remove three nuts (1), washers (2), and bolts (3) that secure three adel clamps (4) to bucket rim and frame. Remove bucket wiring harness (5).
- (2) Attach suitable lifting device to hook assembly (6).
- (3) Remove four leg struts (7) from four bucket unions (8) and four boom strut brackets (9) by removing eight nuts (10), sixteen washers (11), and eight bolts (12).
- (4) Disconnect four strut anchors (13) from two bucket leg weldments (14) by removing four nuts (15), eight washers (16), and four bolts (17).
- (5) Disconnect four leg weldment anchors (18) by removing four nuts (19), eight washers (20), and four bolts (21).

**CAUTION**

Bucket assembly is very heavy. Make sure lifting device is capable of supporting weight of assembled bucket.

- (6) Lift bucket assembly (22) from supporting frame.

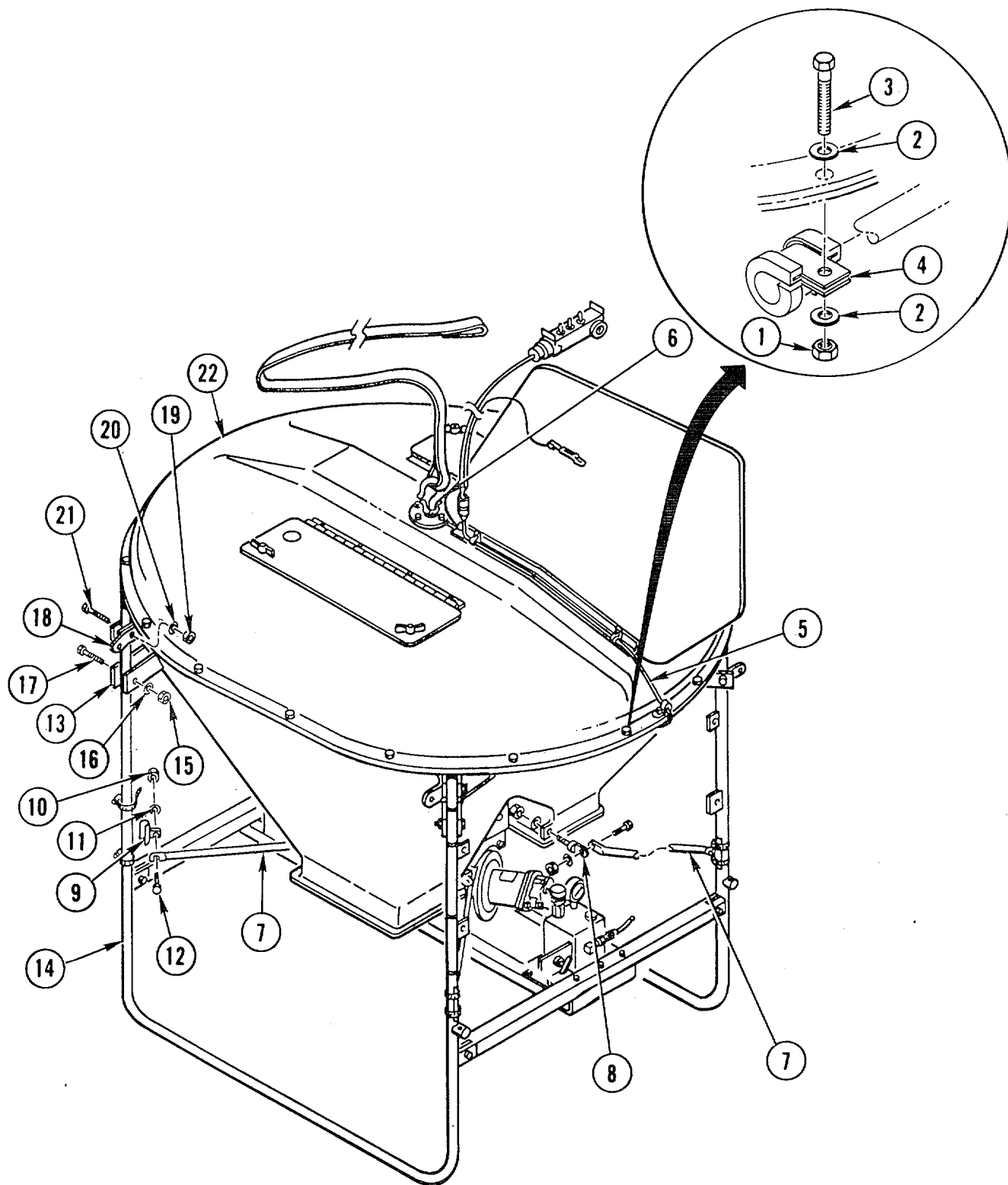

---

**BUCKET ASSEMBLY REPLACEMENT (CONT)**

---

**C. INSTALLATION****CAUTION**

Bucket assembly is very heavy. Make sure lifting device is capable of supporting weight of assembled bucket.

- (1) Attach suitable lifting device to hook assembly (1). Lift bucket assembly (2) and set in place on supporting frame.
- (2) Align four leg weldment anchors (3) on leg weldments (4) and secure using four bolts (5), eight washers (6), and four nuts (7).
- (3) Align four strut anchors (8) with two bucket leg weldments (4) and install four bolts (9), eight washers (10), and four nuts (11).
- (4) Align four leg struts (12) with four bucket unions (13) and four boom strut brackets (14). Install eight bolts (15), sixteen washers (16), and eight nuts (17).
- (5) Remove lifting device from hook assembly (1).
- (6) Install bucket wiring harness (18) on bucket assembly (2) by installing three adel clamps (19) and securing with three bolts (20), washers (21), and nuts (22).

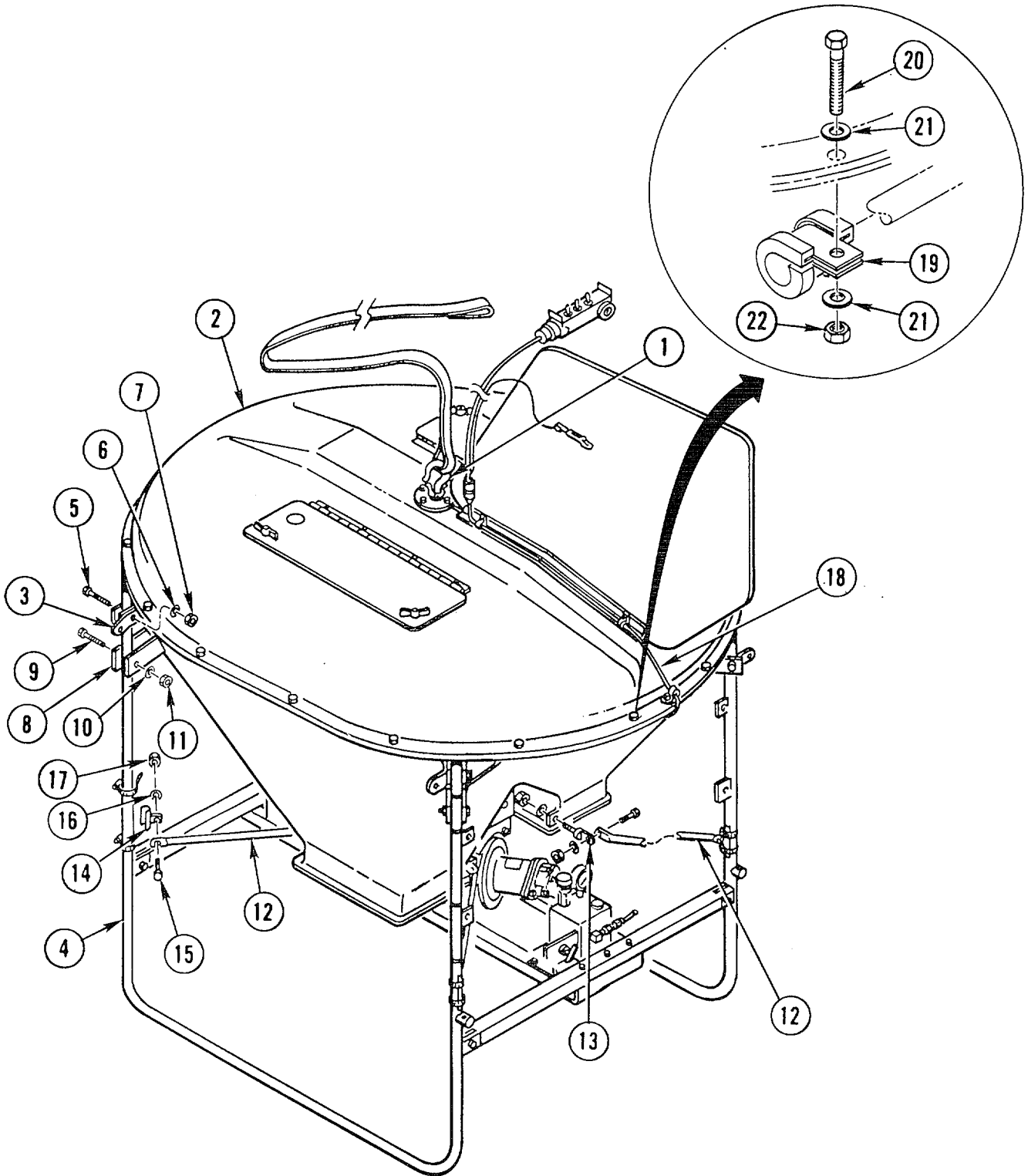



**4-14. DOOR LID ASSEMBLY REPLACEMENT**

---

This task covers: Removal    Installation

---

**A. INITIAL SETUP****Tools and Special Equipment:**

Tool Kit, 5180-00-177-7033  
Drill with 3/16-in. Drill Bit  
Pop Riveter, PRG 430

**Materials/Parts:**

Rivet, Pop (4)

Appendix E, Item 49

---

**B. REMOVAL**

Drill out four pop rivets (1) and remove door assembly (2).

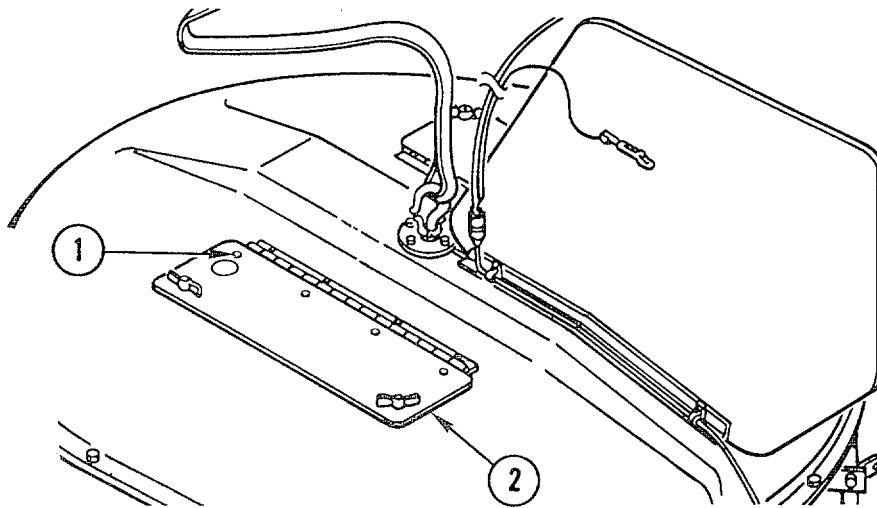
**C. INSTALLATION**

Align door assembly (2) on bucket opening and install four pop rivets (1).

**4-15. DOOR LID ASSEMBLY REPAIR**

This task covers: Disassembly Assembly

**A. INITIAL SETUP**

**Tools and Special Equipment:**

Shop Equipment, 4910-00-754-0654

**Equipment Condition:**

Reference	Condition Description
Paragraph 4-14	Door Lid Assembly Removed

**Materials/Parts:**

Gasket, Lid (2) Appendix E, Item 17

Grommet (2) Appendix E, Item 22

Contact Cement, Appendix E, Item 5  
Barge All-Purpose

**B. DISASSEMBLY**

- (1) Remove and discard gasket (1) from outer edge of door (2).
- (2) Remove and discard two grommets (3) from door latches (4).

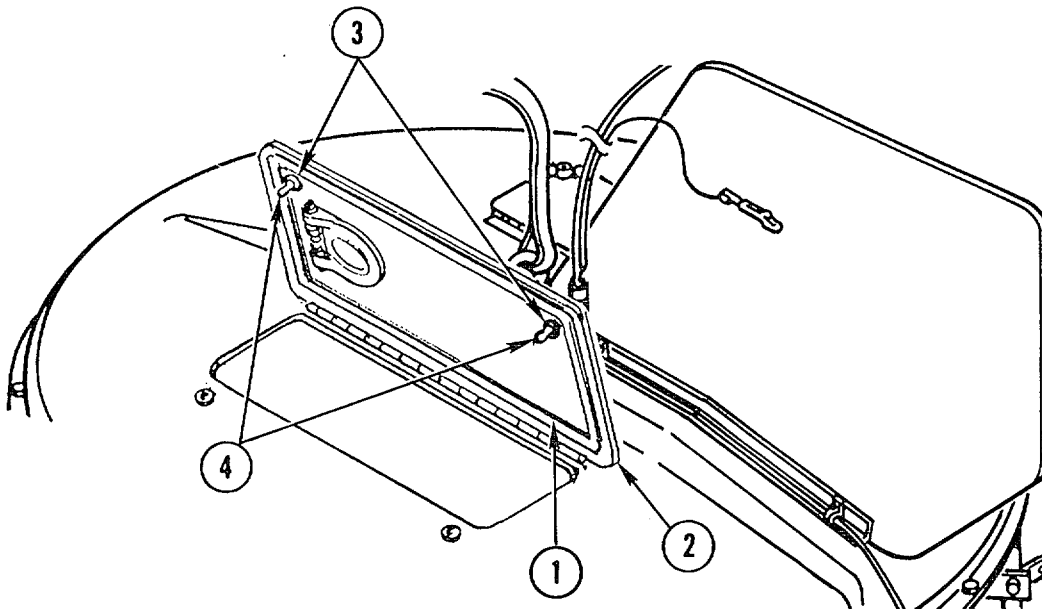

**C. ASSEMBLY**

- (1) Install two new grommets (3) around door latches (4).
- (2) Install new gasket (1) on door (2) using all-purpose contact cement (item 5, Appendix E).

## 4-16. TAIL FIN REPLACEMENT

This task covers: Removal Installation

### A. INITIAL SETUP

#### Tools and Special Equipment:

Tool Kit, 5180-00-177-7033

### B. REMOVAL

- (1) Remove two nuts (1), two washers (2), two screws (3), two washers (2), and two cushion clamps (4) from tail fin bracket (5).
- (2) Slide tail fin (6) out from tail fin bracket (5).

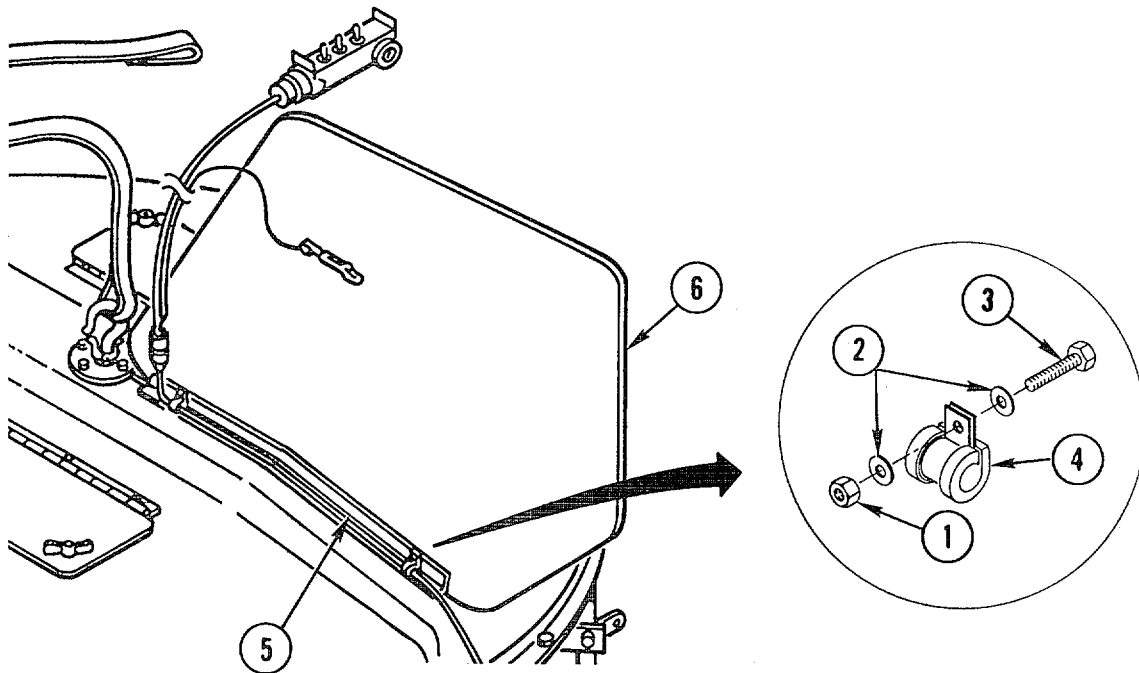

### C. INSTALLATION

- (1) Slide tail fin (6) into tail fin bracket (5).
- (2) Install two cushion clamps (4), two washers (2), two screws (3), two washers (2), and two nuts (1). Tighten.

## 4-17. SLING HOOK ASSEMBLY REPLACEMENT

This task covers: Removal Installation

### A. INITIAL SETUP

#### Tools and Special Equipment:

Tool Kit, 5180-00-177-7033  
Drill with 13/64-in. Drill Bit

### B. REMOVAL

- (1) Open door lid assembly (1).

#### **CAUTION**

Do not allow foreign objects to fall into bucket. Damage to equipment could occur during operation.

- (2) From inside bucket, remove nut (2), two washers (3), and bolt (4) from hook end of support rod (5).
- (3) Remove hook (6) from bucket assembly.

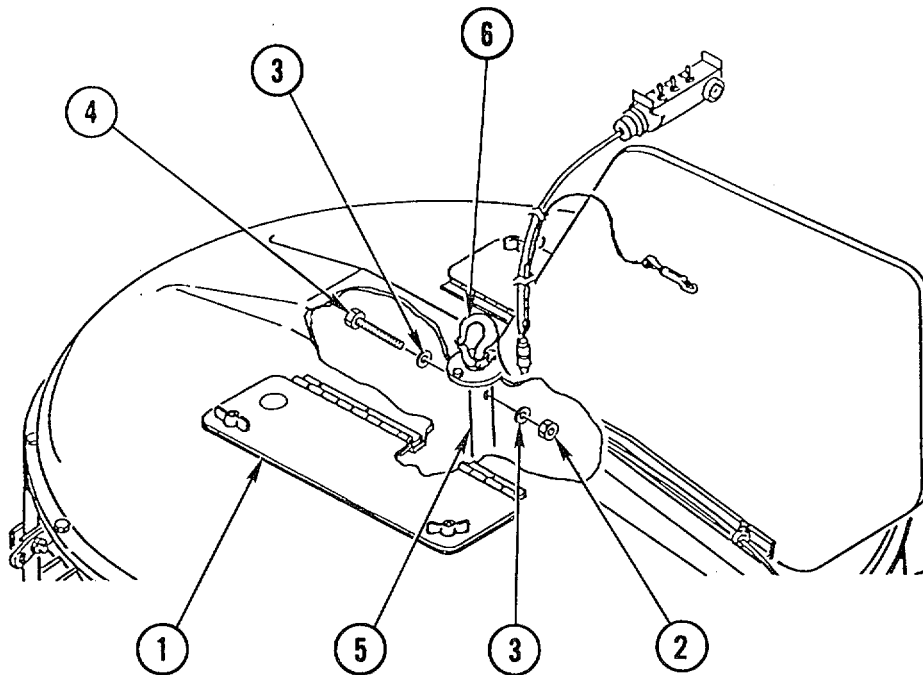

**SLING HOOK ASSEMBLY REPLACEMENT****C. INSTALLATION****NOTE**

Hook shaft is not predrilled.

- (1) Install hook (1) at top of bucket assembly.
- (2) Open door lid assembly (2).
- (3) Using a drill and 13/64-in. drill bit, drill through existing hole at hook end of support rod (3).
- (4) Install bolt (4), two washers (5), and nut (6) on hook end of support rod (3). Tighten.

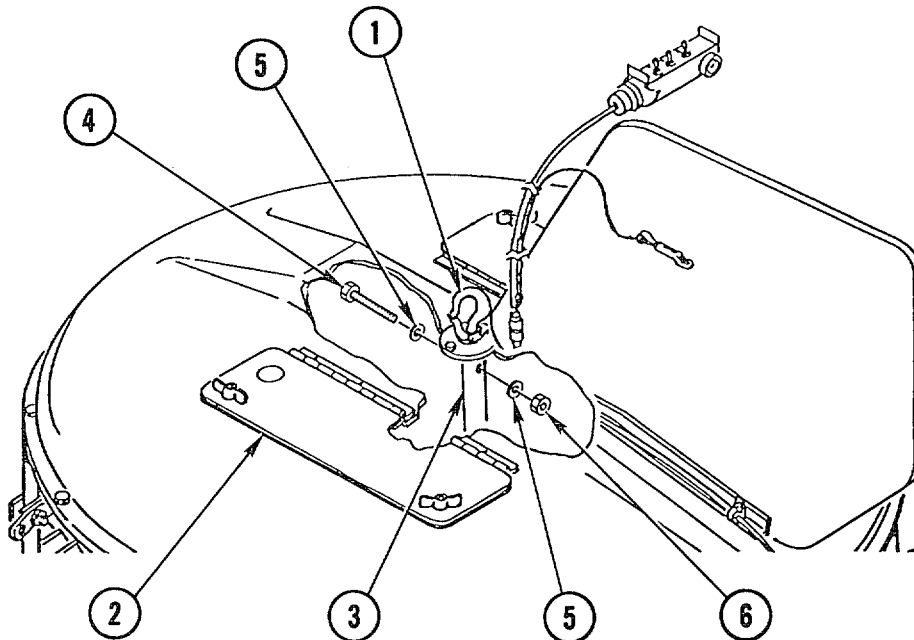

**4-18. ENGINE AND PUMP ASSEMBLY TESTING**

---

This task covers: Testing

---

**A. INITIAL SETUP****Tools and Special Equipment:**

Tool Kit, 5180-00-177-7033

Shop Equipment, 4910-00-754-0654

---

**B. TESTING**

- (1) Install compression gage (1) in spark plug hole (2).
- (2) Crank engine several times with recoil starter (3).
- (3) Check measured compression. Measured compression should be 85-121 psi (6.0-8.5 kg/cm).
- (4) If compression reading is abnormal, replace engine (para 4-19).

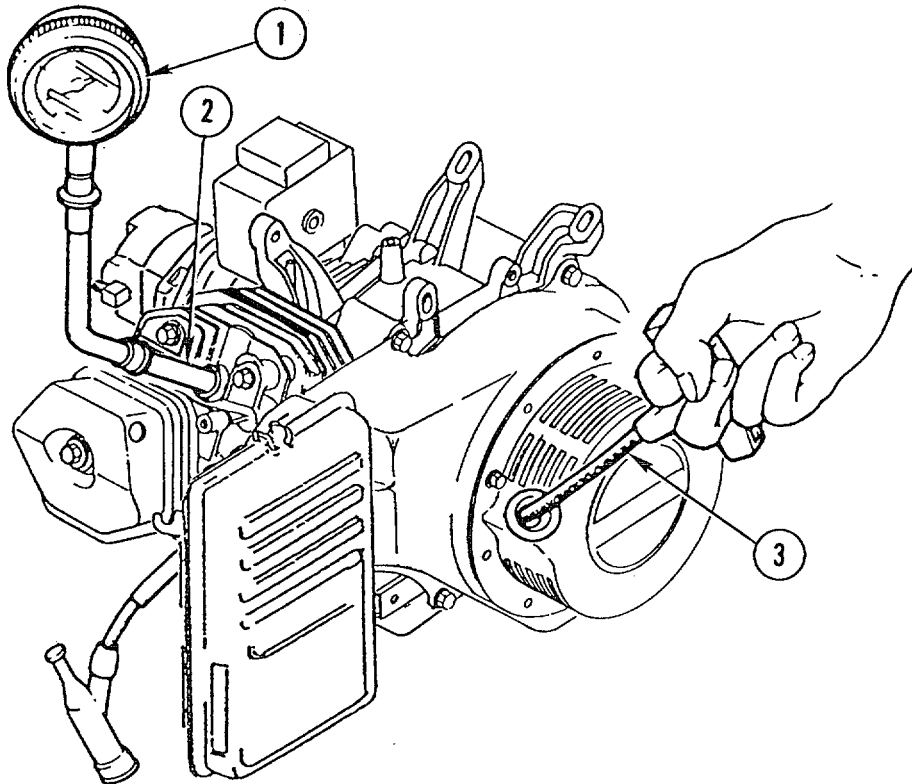

**4-19. ENGINE AND PUMP ASSEMBLY REPLACEMENT**

---

This task covers: Removal    Installation

---

**A. INITIAL SETUP**

**Tools and Special Equipment:**

Tool Kit, 5180-00-177-7033

**Personnel Required:** (2)

**Equipment Condition:**

<b>Reference</b>	<b>Condition Description</b>
Paragraph 4-39	Pump and Crosstube Assembly Removed
Paragraph 4-51	Motor and Slinger Assembly Removed
Paragraph 4-53	Hopper Assembly Removed
Paragraph 4-33	Battery Removed
Paragraph 4-34	Hydraulic Reservoir Drained

**General Safety Instructions:**

**WARNING**

Gasoline is flammable. Do not work on fuel system in presence of sparks and open flame. Serious personal injury could result if fuel ignites.

Engine is heavy and cumbersome. Use two persons when lifting or moving engine to prevent personal injury.

---

**NOTE**

This task can be used for engine replacement only. Hydraulic pump can be removed from engine without disconnecting inlet and outlet hoses. Do not drain hydraulic reservoir if inlet and outlet hoses to pump are left connected.

---

**4-19. ENGINE AND PUMP ASSEMBLY REPLACEMENT (CONT)**

---

**B. REMOVAL****WARNING**

Gasoline is flammable. Do not work on fuel system in presence of sparks and open flame. Serious personal injury could result if fuel ignites.

- (1) Disconnect spark plug wire (1).
- (2) Shut off fuel at fuel strainer petcock (2).
- (3) Remove nut (3), washer (4), bolt (5), and adel clamp (6) securing fuel line (7).
- (4) Disconnect fuel line (7) from carburetor (8).
- (5) Remove bolt (9), washer (10), and adel clamp (11) securing throttle cable (12).
- (6) Disconnect throttle cable (12) from carburetor (8).
- (7) Disconnect and tag starter solenoid electrical leads (13).
- (8) Disconnect and tag six banana clip wires (14) from bucket harness.
- (9) Disconnect and tag four ground wires (15) from rear of engine case ground stud (16).
- (10) Disconnect inlet (17) and outlet (18) hydraulic hoses from hydraulic pump (19). Tag hoses and cap open hydraulic lines.
- (11) Disconnect engine assembly (20) from isolators (21) by removing four nuts (22), eight washers (23), and four bolts (24).

**WARNING**

Engine is heavy and cumbersome. Use two persons when lifting or moving engine to prevent personal injury.

- (12) Using two persons, lift engine assembly (20) free of isolators (21) and away from PDU.



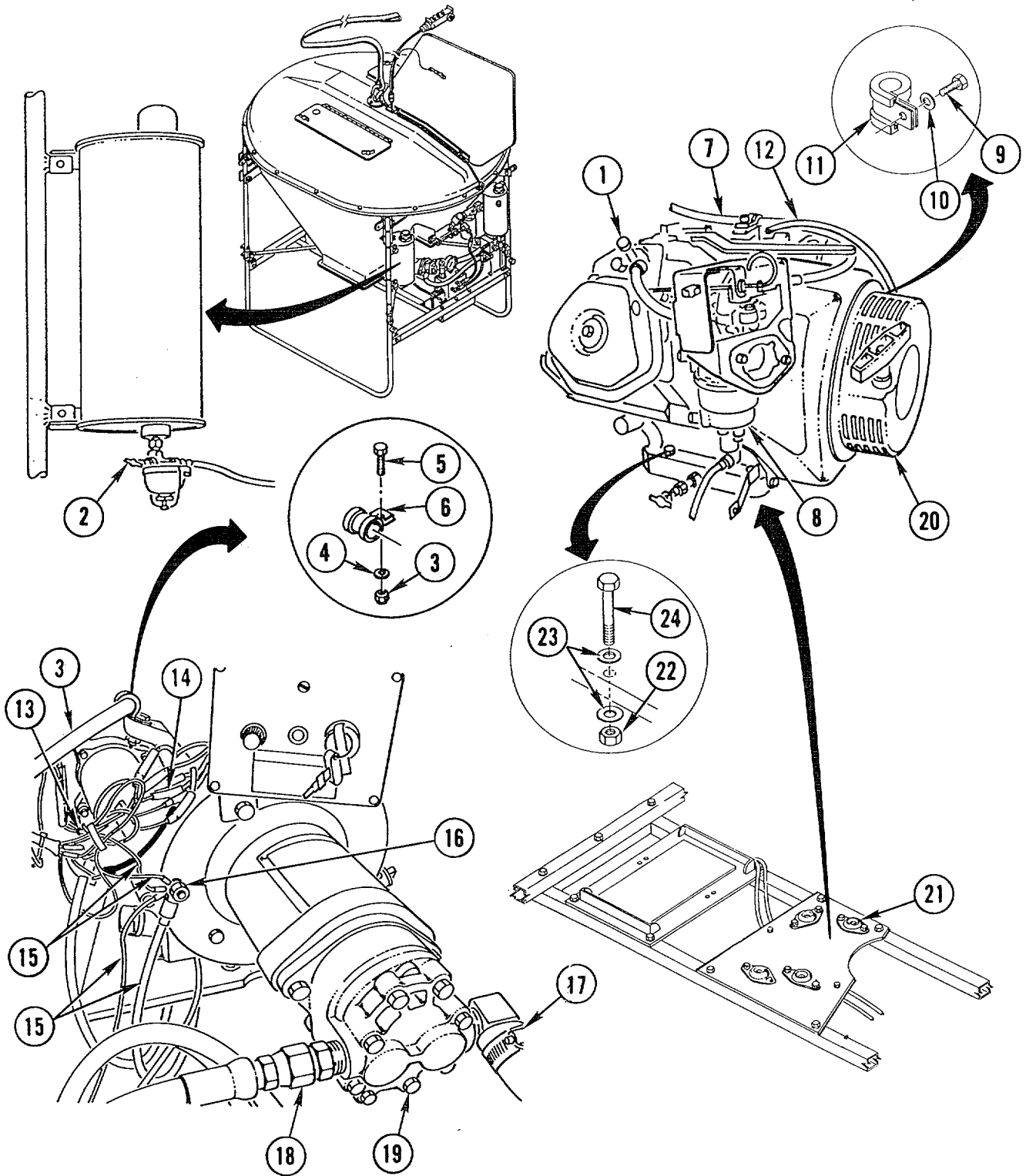

---

**4-19. ENGINE AND PUMP ASSEMBLY REPLACEMENT (CONT)**

---

**C. INSTALLATION****WARNING**

Gasoline is flammable. Do not work on fuel system in presence of sparks and open flame. Serious personal injury could result if fuel ignites.

Engine is heavy and cumbersome. Use two persons when lifting or moving engine to prevent personal injury.

- (1) Using two persons, lift engine assembly (1). Align engine with isolators (2) and place engine assembly (1) on isolators (2).
- (2) Install four washers (3) on four bolts (4). Install four bolts (4) through bottom side of isolators (2) through engine mount holes. Install four washers (3) and four nuts (5) to secure engine. Torque nuts to 25 lb-ft (34 N.m).
- (3) Remove caps and connect inlet (6) and outlet (7) hydraulic hoses to hydraulic pump (8).
- (4) Connect four ground wires (9) to rear of engine case ground stud (10).
- (5) Connect six banana clip wires (11) to bucket harness.
- (6) Connect starter solenoid electrical leads (12) to starter solenoid.
- (7) Connect throttle cable (13) to carburetor (14).
- (8) Secure throttle cable (13) to engine (1) with adel clamp (15), washer (16), and bolt (17).
- (9) Connect fuel line (18) to carburetor (14).
- (10) Secure fuel line (18) with adel clamp (19), bolt (20), washer (21), and nut (22).
- (11) Turn fuel strainer petcock (23) to ON position.
- (12) Connect spark plug wire (24).
- (13) Fill hydraulic reservoir (para 4-34).

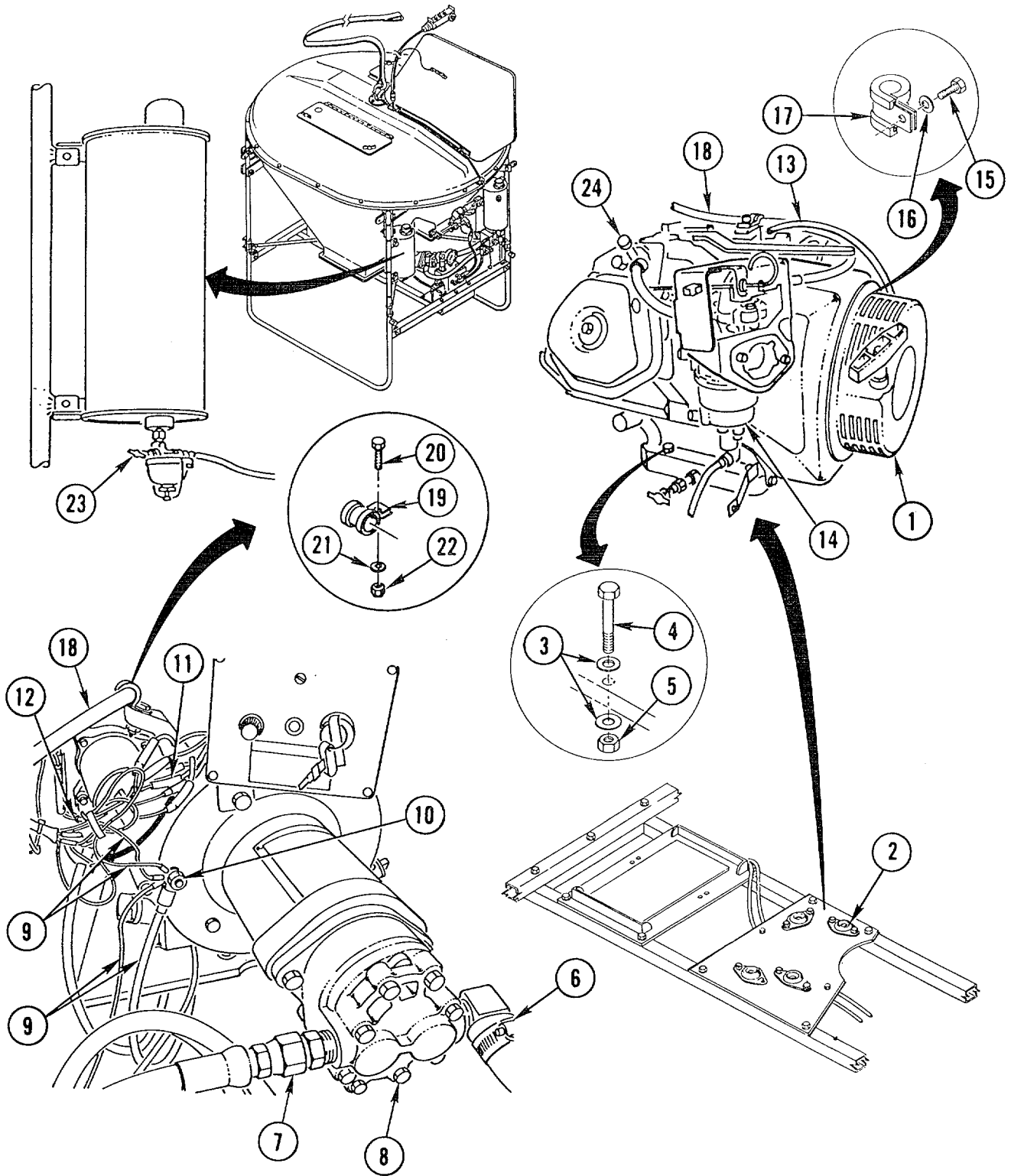

**4-20. KEY SWITCHBOX ASSEMBLY REPLACEMENT**

---

This task covers:      Removal                      Installation

---

**A. INITIAL SETUP****Tools and Special Equipment:**

Tool Kit, 5180-00-177-7033

**Equipment Condition:**

Reference	Condition Description
Paragraph 4-31 Disconnected	Battery Cables
Paragraph 4-25	Spark Plug Removed

**B. REMOVAL****NOTE**

Tag electrical leads prior to removal to aid in installation.

- (1) Disconnect bucket harness connection A1 (1) (black and red wire).
- (2) Disconnect bucket harness connection B1 (2) (white wire).
- (3) Disconnect bucket harness connection B2 (3) (white wire).
- (4) Disconnect charging coil connection (4).
- (5) Disconnect bucket harness connection J2 (5) (white with red dot wire).
- (6) Disconnect yellow and green oil level switch electrical leads (6).
- (7) Disconnect starter solenoid electrical leads (7).
- (8) Remove switchbox assembly front panel (8) by removing four screws (9).
- (9) Remove key switchbox assembly (10) from engine angle (11) by removing two nuts (12), four washers (13), and two bolts (14).

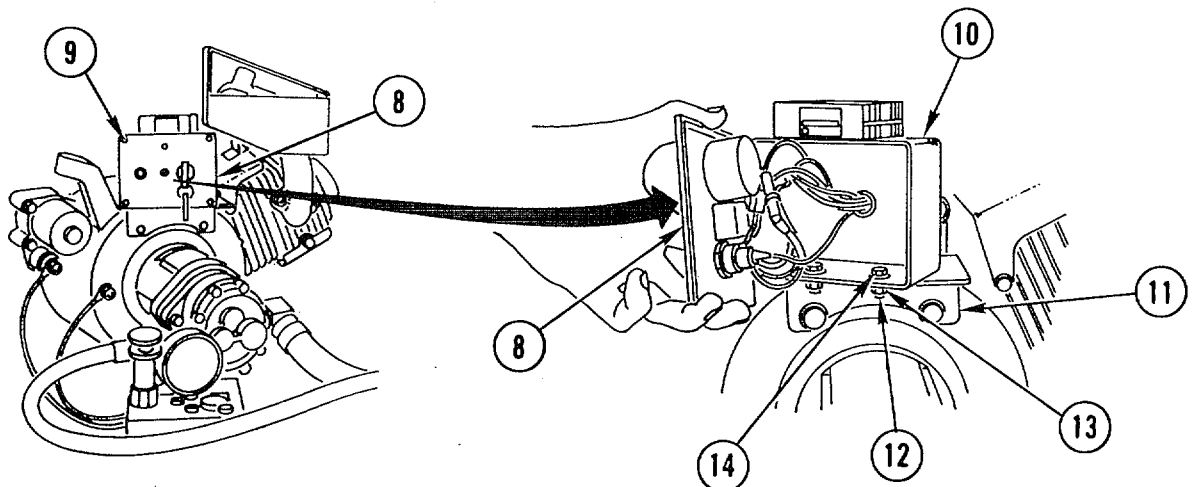
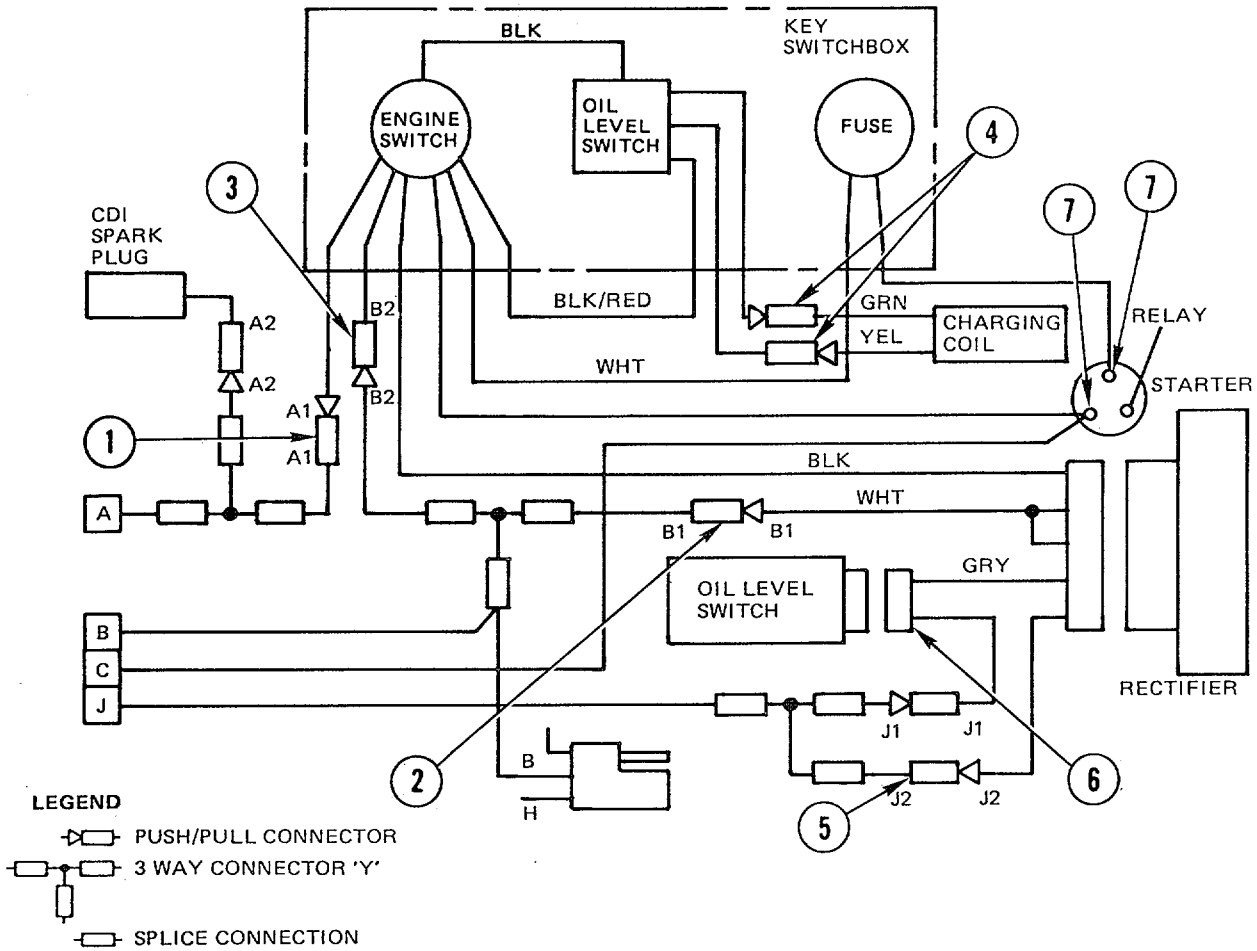

---

**4-20. KEY SWITCHBOX ASSEMBLY REPLACEMENT (CONT)**

---

**C. INSTALLATION**

- (1) Attach key switchbox assembly (1) to engine angle (2) by installing two bolts (3), four washers (4), and two nuts (5).
- (2) Attach key switchbox assembly front panel (6) by installing four screws (7).
- (3) Connect starter solenoid electrical leads (8).
- (4) Connect yellow and green oil level switch electrical leads (9).
- (5) Connect bucket harness connection J2 (10) (white with red dot wire).
- (6) Connect charging coil connection (11).
- (7) Connect bucket harness connection B2 (12) (white wire).
- (8) Connect bucket harness connection B1 (13) (white wire).
- (9) Connect bucket harness connection A1 (14) (black and red wire).

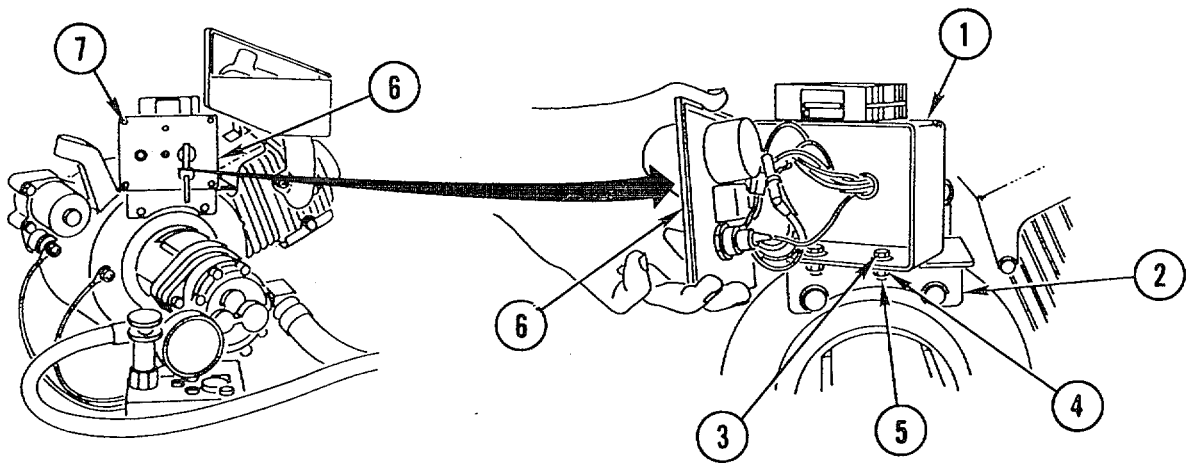
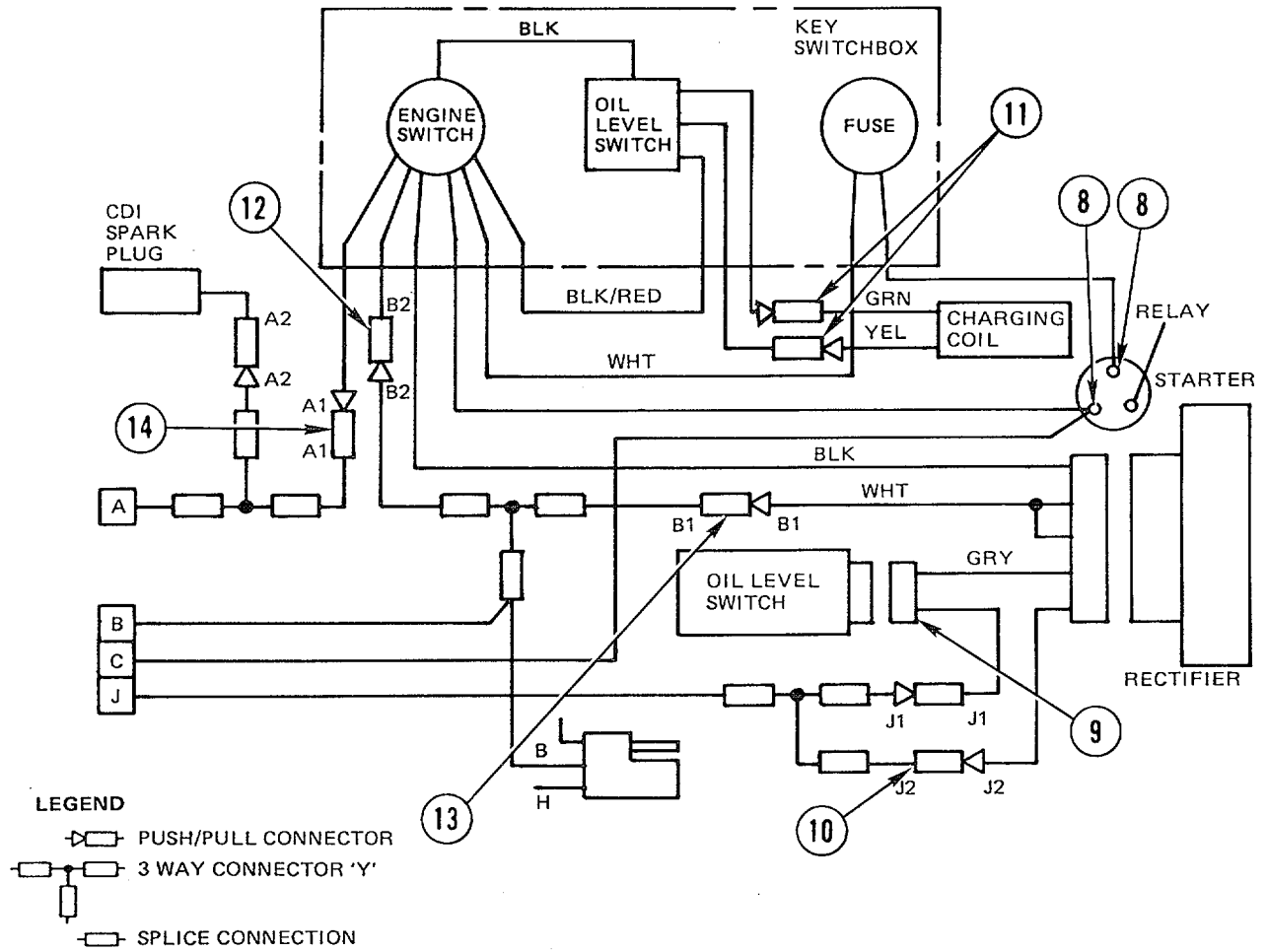





---

**CARBURETOR REPLACEMENT/REPAIR (CONT)**

---

**B. REMOVAL/DISASSEMBLY****WARNING**

Gasoline is flammable. Do not work on fuel system in presence of sparks and open flame. Serious personal injury could result if fuel ignites.

**NOTE**

Electrical lead at bottom of carburetor is provided by manufacturer to provide electrical choke. Carburetor uses vacuum choke. Therefore, electrical leads are not used and are stubbed, but must be disconnected during removal of carburetor.

- (1) Disconnect gas line (1) from carburetor (2).
- (2) Unhook throttle return spring (3).
- (3) Unhook choke assembly (4).
- (4) Disconnect vacuum tube (5) from solenoid stay assembly (6).
- (5) Pull solenoid stay assembly (6) forward off support studs.
- (6) Remove and discard stay assembly gasket (7).
- (7) Pull carburetor (2) forward until groove in throttle arm lines up with governor rod (8).
- (8) Lift governor rod (8) out of hole. Remove carburetor (2).
- (9) Remove and discard carburetor gasket (9).
- (10) Remove spark plug wire (10) from insulator clips.
- (11) Remove carburetor insulator (11) with gasket (12). Discard gasket.
- (12) Remove dashpot check valve (13) from vacuum tube (5).

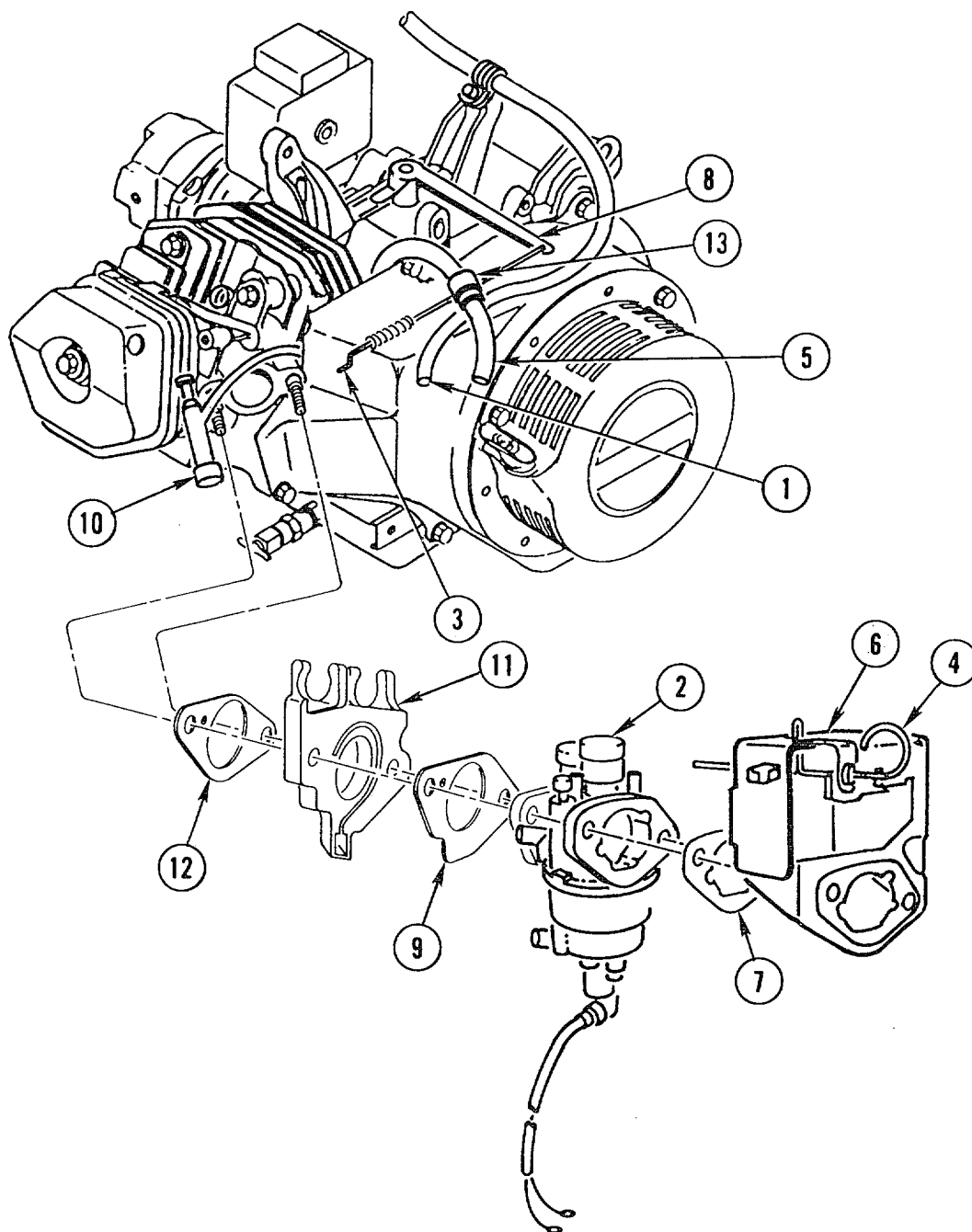

---

**CARBURETOR REPLACEMENT/REPAIR (CONT)**

---

**C. ASSEMBLY/INSTALLATION****WARNING**

Gasoline is flammable. Do not work on fuel system in presence of sparks and open flame. Serious personal injury could result if fuel ignites.

- (1) Install dashpot check valve (1) between two pieces of vacuum tube (2).
- (2) Install new gasket (3), carburetor insulator (4), and new gasket (5) on support studs.
- (3) Install spark plug wire (6) in insulator clips.
- (4) Push governor rod (7) into hole on carburetor (8).
- (5) Install carburetor (8) on support studs.
- (6) Install throttle return spring (9).
- (7) Connect gas line (10) to carburetor (8).
- (8) Align choke assembly (11) on solenoid stay assembly (12).
- (9) Push solenoid stay assembly (12) onto support studs.
- (10) Connect vacuum tube (2) to solenoid stay assembly (12).
- (11) Install new stay assembly gasket (13).
- (12) Install air cleaner (para 4-22) and adjust carburetor idle speed as described in Adjustment, following.

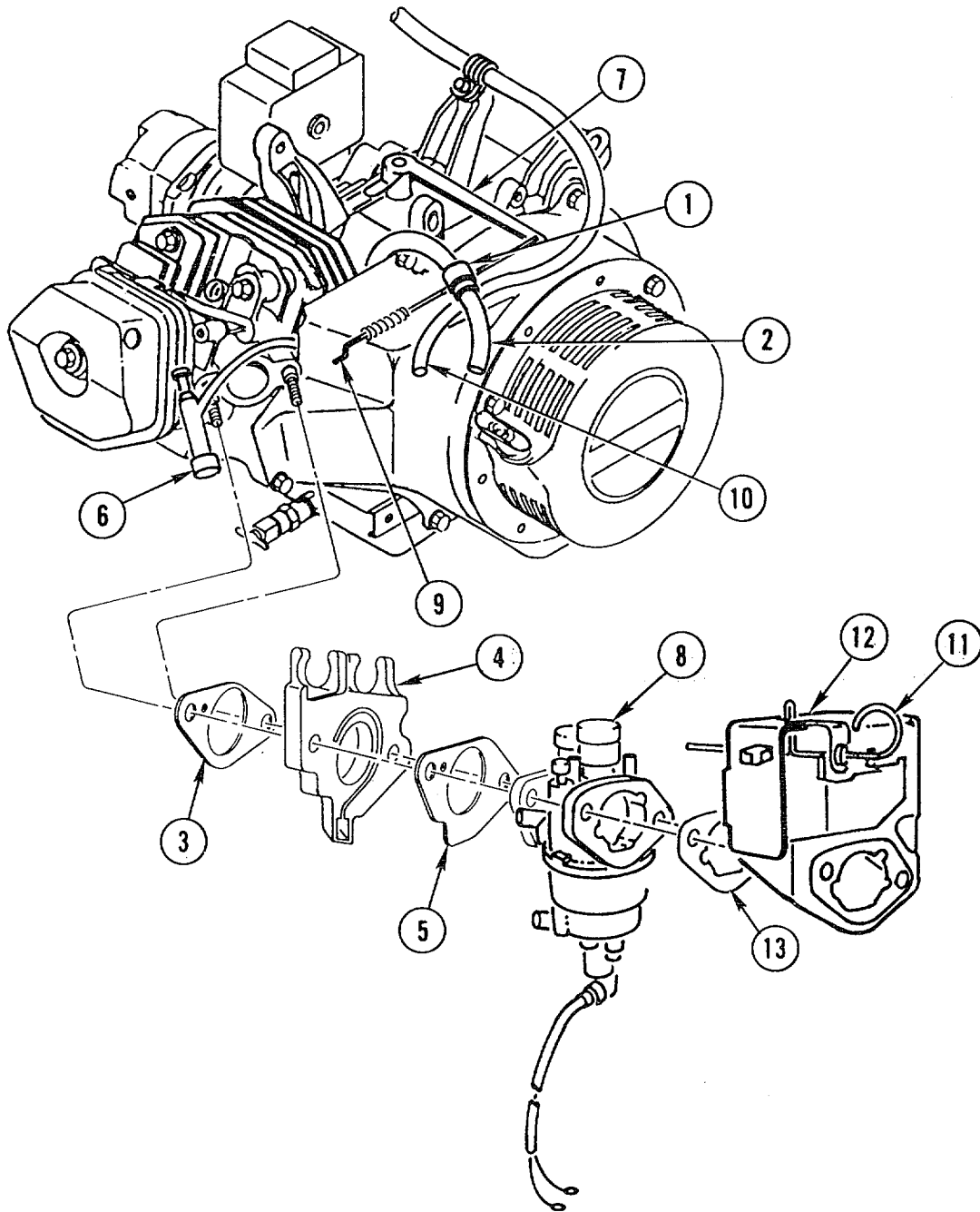

---

**CARBURETOR REPLACEMENT/REPAIR (CONT)**

---

**D. ADJUSTMENT****NOTE**

Adjust carburetor idle speed at least once a year.

- (1) Start engine and allow it to warm to normal operating temperature.
- (2) With engine idling, turn pilot screw (1) until it bottoms lightly.
- (3) Back off pilot screw (1) two turns.
- (4) Turn throttle stop screw (2) in or out as necessary until  $1400 \pm 150$  psi is obtained on primary manifold pressure gage.

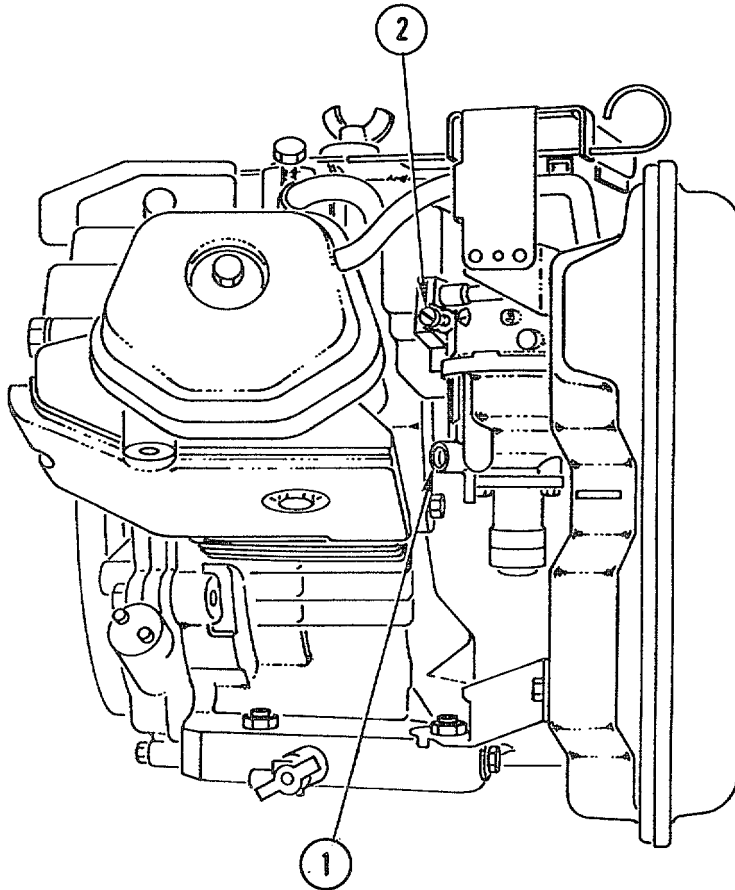

**4-22. AIR CLEANER REPLACEMENT/REPAIR**

---

This task covers:	Removal/Disassembly	Cleaning	Assembly/Installation
-------------------	---------------------	----------	-----------------------

---

**A. INITIAL SETUP**

**Tools and Special Equipment:**

Tool Kit, 5180-00-177-7033  
 Shop Equipment, 4910-00-754-0654

**Materials/Parts:**

Filter, Drain Tube    Appendix E, Item 9  
 Solvent, High Flashpoint    Appendix E, Item 60  
 Oil, Engine    Appendix E, Item 36  
 Seal    Appendix E, Item 50

**Equipment Condition:**

Reference	Condition Description
Paragraph 4-33	Battery Removed

**General Safety Instructions:**

**WARNING**

Do not use gasoline or low flashpoint solvent for cleaning. Both are flammable and explosive under certain conditions. Serious personal injury could result if fuel ignites.

Death or serious injury could result by repeated and/or prolonged breathing and/or skin contact of drycleaning solvent (P-D-680). Use in a well-ventilated area. Do not use near open flame or in excessive heat. The flash point of this solvent is 100°F-183°F (38°C-59°C).

---

**AIR CLEANER REPLACEMENT/REPAIR (CONT)**

---

**B. REMOVAL/DISASSEMBLY**

- (1) Release top and bottom clips (1) and remove air cleaner cover (2).
- (2) Remove air cleaner element (3).
- (3) Remove six nuts (4).
- (4) Remove separator (5) and seal (6) from air cleaner case (7). Discard seal (6) if damaged.
- (5) Remove two nuts (8) from carburetor mounting studs.
- (6) Remove nut (9) from air cleaner stay (10) in back of air cleaner case (7).
- (7) Remove breather tube (11) from cylinder head and pull air cleaner case (7) off carburetor mounting studs.
- (8) Remove and discard drain tube filter (12).

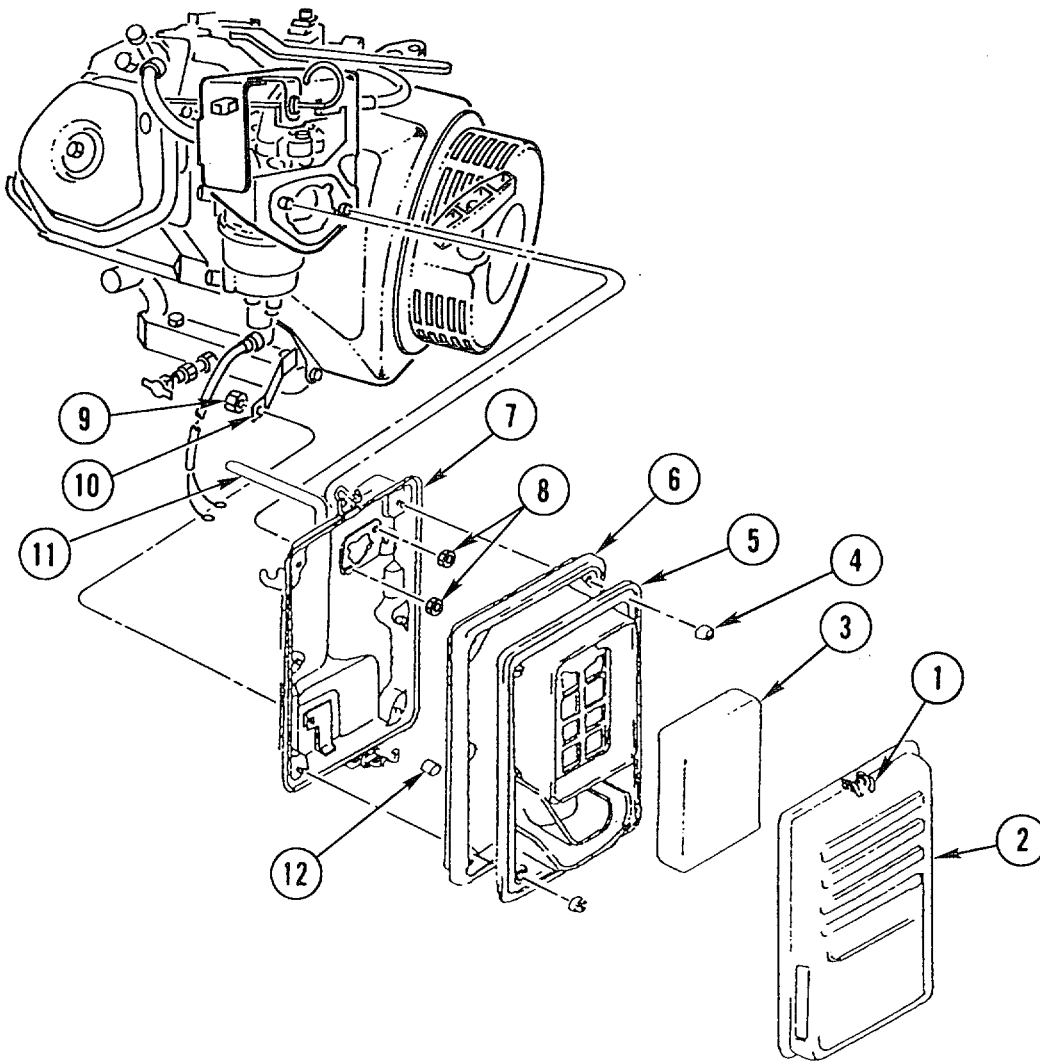



---

**AIR CLEANER REPLACEMENT/REPAIR (CONT)**

---

**C. CLEANING**

- (1) Use general cleaning methods to clean all parts (para 1-15) except filter element.

**WARNING**

Do not use gasoline or low flashpoint solvent for cleaning. Both are flammable and explosive under certain conditions. Serious personal injury could result if fuel ignites.

Death or serious injury could result by repeated and/or prolonged breathing and/or skin contact of drycleaning solvent (P-D-680). Use in a well-ventilated area. Do not use near open flame or in excessive heat. The flash point of this solvent is 100°F-183°F (38°C-59°C).

- (2) Wash filter element in high flashpoint solvent (item 60, Appendix E) and dry.
- (3) Dip filter element in clean engine oil (item 36, Appendix E) and squeeze out excess oil.

**D. ASSEMBLY/INSTALLATION**

- (1) Place air cleaner case (1) in position on air cleaner stay (2).
- (2) Install two nuts (3) on carburetor mounting studs.
- (3) Secure air cleaner case (1) to stay (2) using nut (4).
- (3) Install breather tube (5).
- (4) Install new drain tube filter (6).
- (5) Install new seal (7) and separator (8) on air cleaner case (1) and secure using six nuts (9).
- (6) Place air cleaner element (10) in separator (8).
- (7) Place air cleaner cover (11) on separator (8) and secure with top and bottom clips (12).

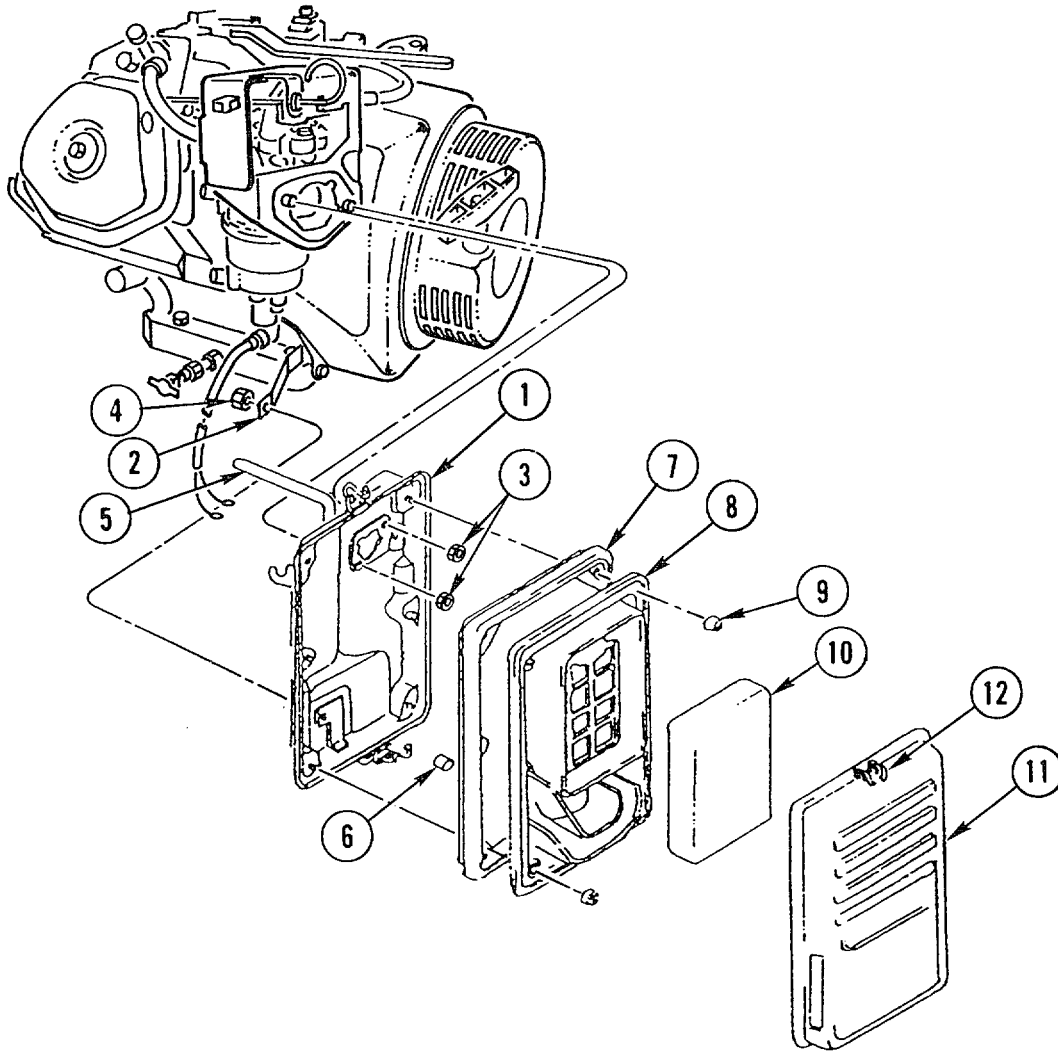

## 4-23. MUFFLER ASSEMBLY REPLACEMENT

This task covers:      Removal                  Installation

---

### A. INITIAL SETUP

Tools and Special Equipment:

Tool Kit, 5180-00-177-7033

### General Safety Instructions

#### WARNING

Make sure muffler and engine are cooled down before attempting assembly, disassembly, or adjustments. Hot muffler and engine components can cause burns.

### B. REMOVAL

#### WARNING

Make sure muffler and engine are cooled down before attempting assembly, disassembly, or adjustments. Hot muffler and engine components can cause burns.

Remove two flange nuts (1) and muffler assembly (2).

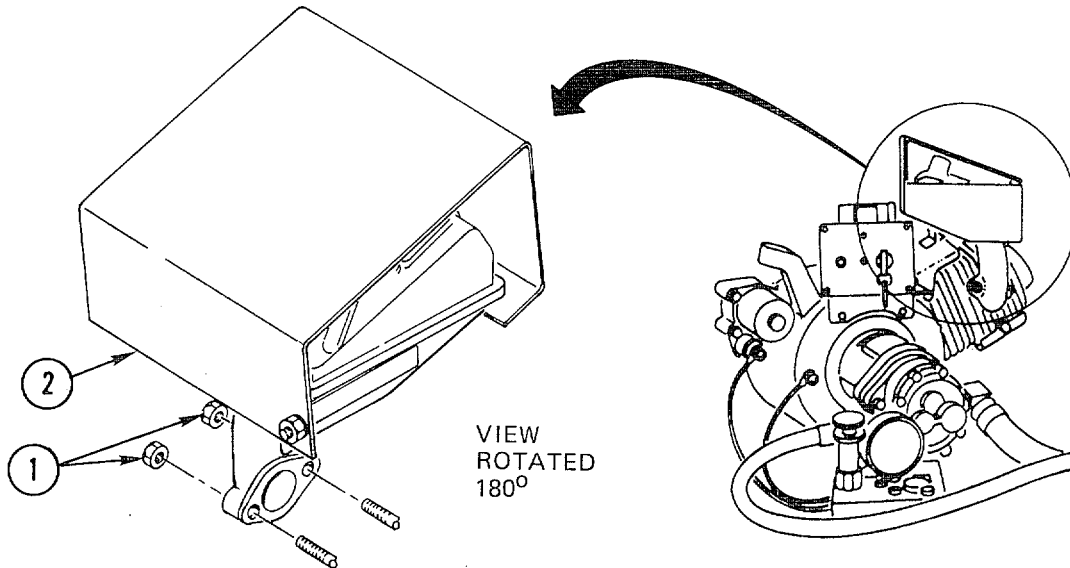

### C. INSTALLATION

Install muffler assembly (2) on manifold guide studs and install two flange nuts (1).

Torque flange nuts to 16-19 lb-ft (22-26 N.m).

**4-24. MUFFLER ASSEMBLY REPAIR**

---

This task covers:      Disassembly      Cleaning      Assembly

---

**A. INITIAL SETUP**

Tools and Special Equipment:

Tool Kit, 5180-00-177-7033

**Materials/Parts:**

Gasket                      Appendix E, Item 14

Equipment Condition:

Reference	Condition Description
-----------	-----------------------

Paragraph 4-23	Muffler Assembly Removed
----------------	-----------------------------

**MUFFLER ASSEMBLY REPAIR (CONT)**

**B. DISASSEMBLY**

- (1) Remove heat shield (1) by removing three bolts (2), six washers (3), nut (4), washer (5), and bolt (6).
- (2) Disconnect muffler exhaust tube (7) from muffler (8) by removing two nuts (9) and two washers (10).
- (3) Remove two bolts (11) and two washers (12) from top of muffler (8).
- (4) Remove and discard muffler gasket (13).

**C. CLEANING**

Use plastic hammer to remove carbon deposits from muffler exhaust tube and muffler.

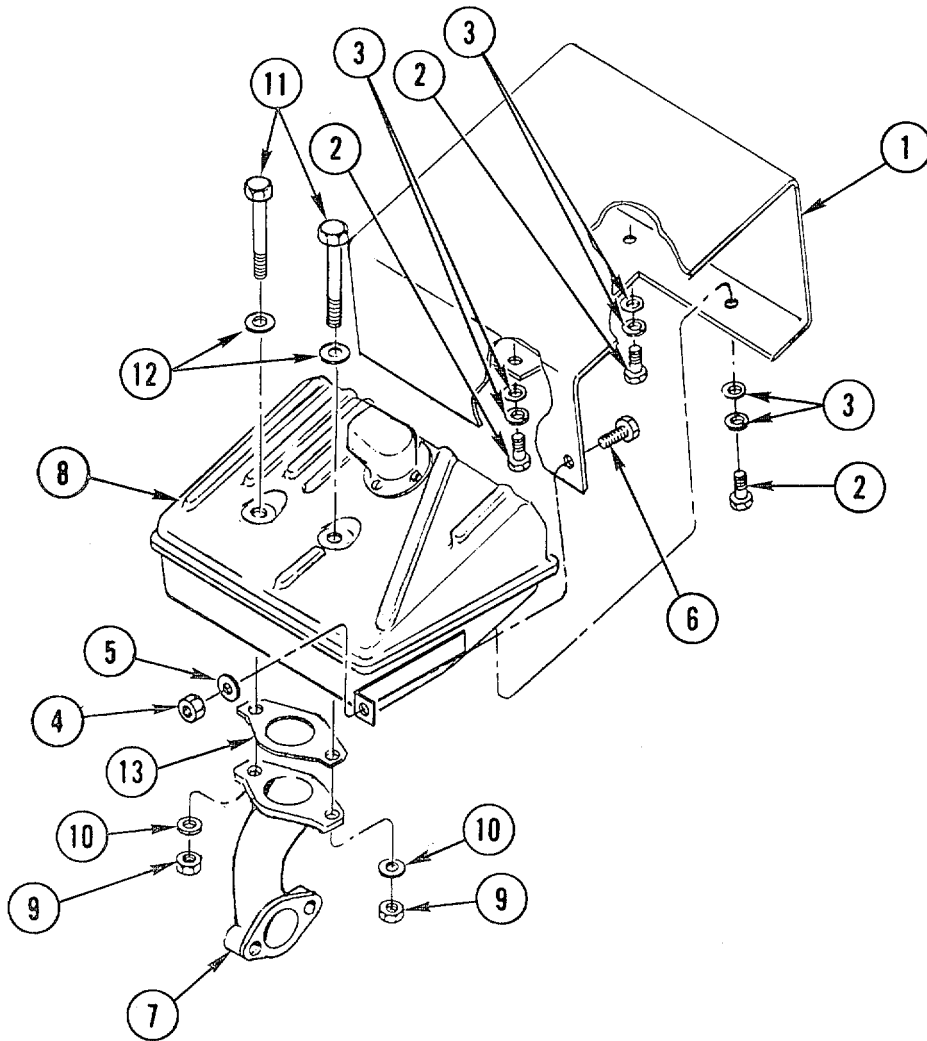

**D. ASSEMBLY**

- (1) Install two washers (1) and two bolts (2) through top of muffler (3).
- (2) Align new muffler gasket (4) and muffler exhaust tube (5) on muffler (3).
- (3) Install two washers (6) and two nuts (7) on ends of bolts (2) to secure muffler exhaust tube (5) to muffler (3). Tighten nuts and bolts securely.
- (4) Align heat shield (8) on muffler (3) and install six washers (9) and three bolts (10) on heat shield.
- (5) Install bolt (11), washer (12), and nut (13) on bracket weldment and tighten securely.

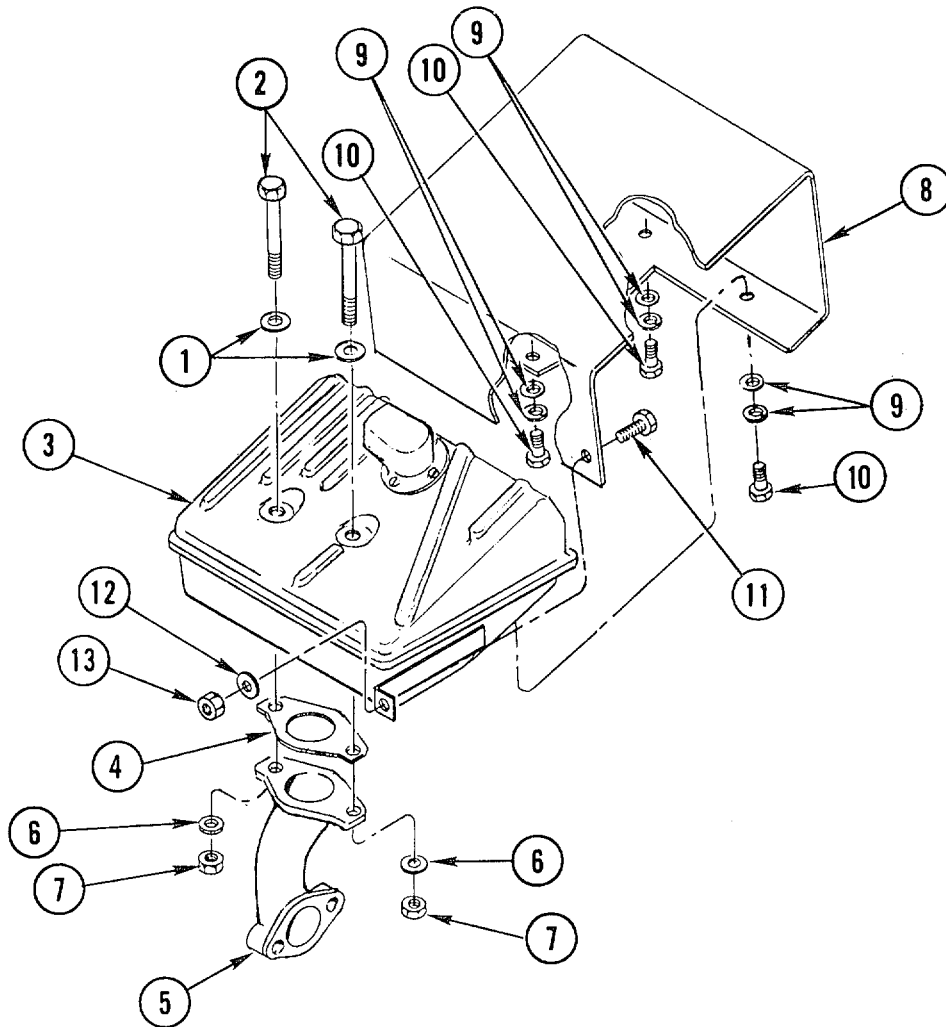

**4-25. SPARK PLUG REPLACEMENT**

---

This task covers:      Removal                      Installation

---

**A. INITIAL SETUP**

**Tools and Special Equipment:**

Tool Kit, 5180-00-177-7033  
 Spark Plug Wrench  
 Wire Feeler Gage

**Equipment Condition:**

Reference	Condition Description
Paragraph 4-31	Battery Cables Disconnected

---

**B. REMOVAL**

- (1) Remove plug cap (1).
- (2) Remove spark plug (2) using spark plug wrench.

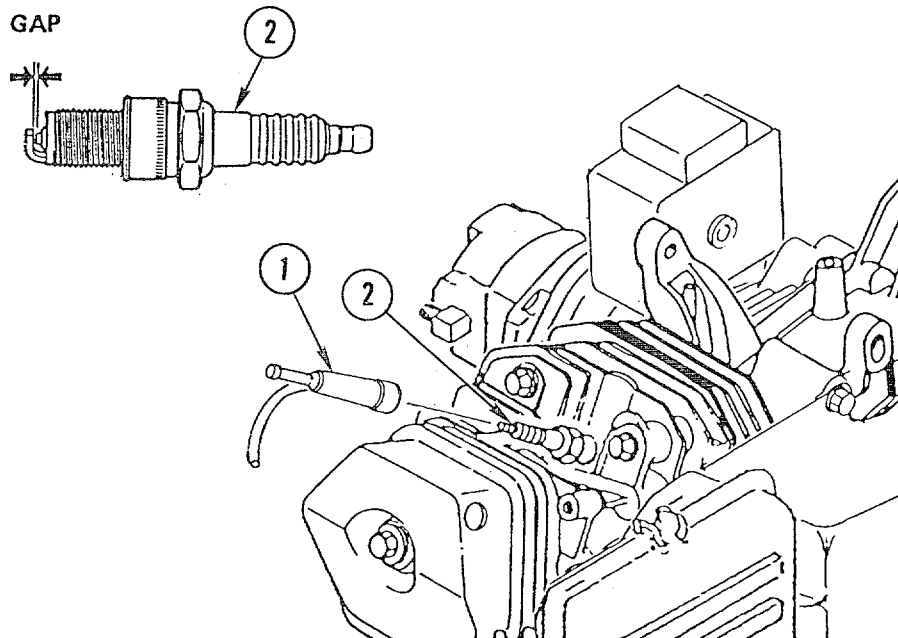

**C. INSTALLATION****CAUTION**

Spark plug must be securely tightened. Improperly tightened plug can become very hot and cause engine damage.

Spark plug must have correct heat range.

- (1) Check plug electrode gap with wire feeler gage.
- (2) Correct gap as necessary by bending side electrode (1). Electrode gap should be 0.039-0.043 in. (1.0-1.1 mm).
- (3) Make sure sealing washer (2) is in good condition and, with washer attached, hand-thread spark plug (3) to prevent cross-threading.
- (4) Use spark plug wrench to tighten an additional 1/2 turn.
- (5) Install plug cap (4).

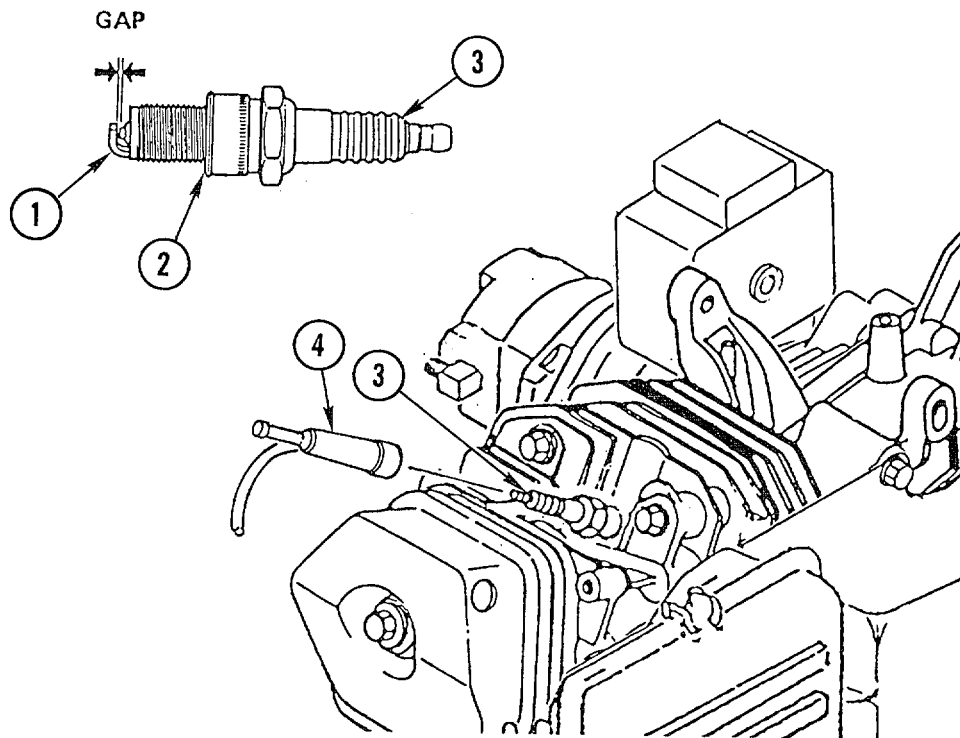



**4-26. OIL FILL AND DRAIN ASSEMBLY REPAIR**

---

 This task covers:      Disassembly      Assembly
 

---

**A. INITIAL SETUP****Tools and Special Equipment:**

Tool Kit, 5180-00-177-7033  
Multimeter, AN/URM 105

**Materials/Parts:**

Gasket	Appendix E, Item 16
Oil, SAE 10W-40	Appendix E, Item 40

---

**B. DISASSEMBLY****NOTE**

Oil alert system should be checked when engine oil is changed. (Refer to table 4-1, Unit Level PMCS.) Oil level switch is not replaceable. If inspection or testing shows oil level switch to be defective, engine must be replaced (para 4-19).

- (1) Remove oil filler cap/dipstick (1).
- (2) Remove oil inspection cap (2) and gasket (3). Discard gasket.
- (3) Place suitable container under drain petcock (4) on engine. Turn drain petcock counterclockwise and drain engine oil.
- (4) When engine oil is drained, remove drain plug (5) and washer (6).

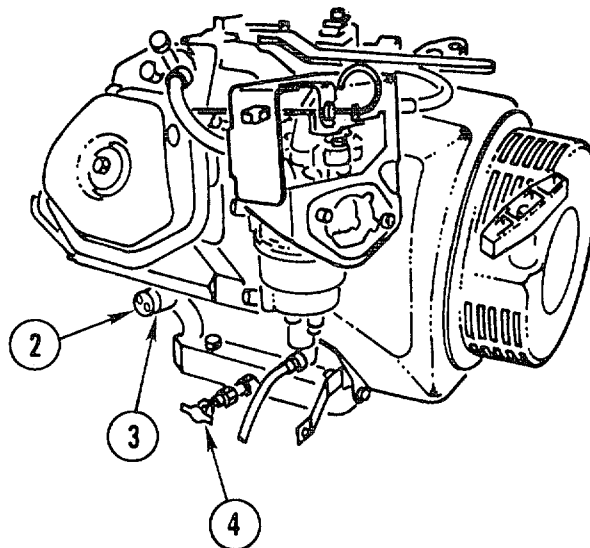
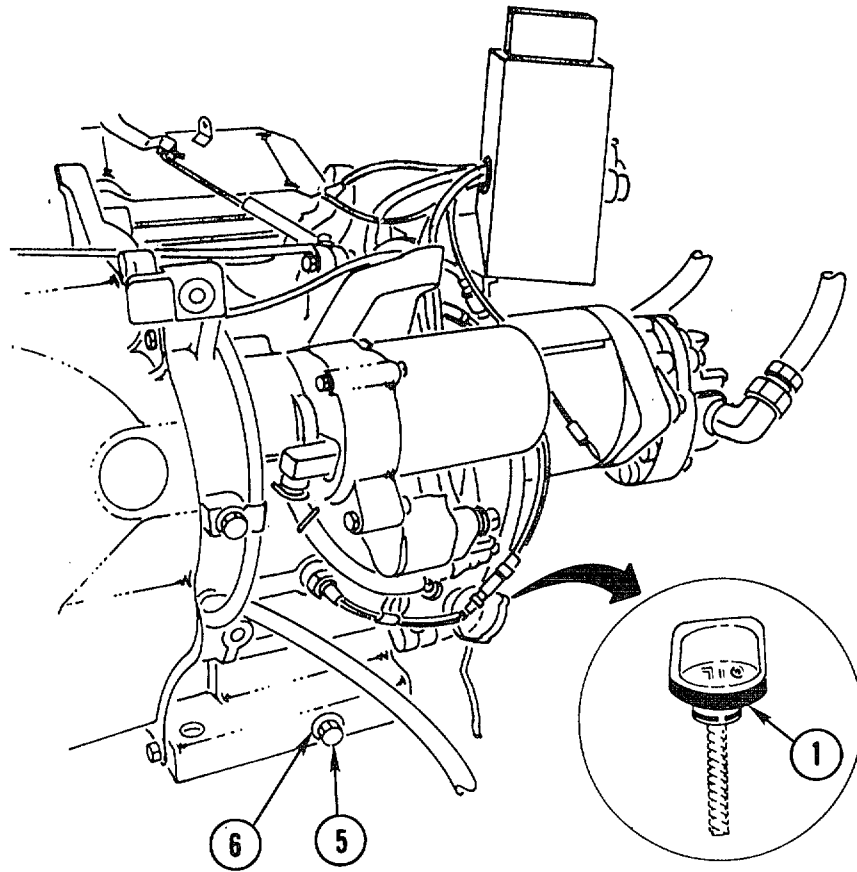

---

**OIL FILL AND DRAIN ASSEMBLY REPAIR (CONT)**

---

**C. ASSEMBLY**

- (1) Hand-thread washer (1) and drain plug (2) on engine. Torque drain plug to 14.5-18.1 ft-lb (20-25 N.m).
- (2) Turn drain petcock (3) clockwise.
- (3) Hand-thread new gasket (4) and oil inspection cap (5) on engine. Use screwdriver to tighten oil inspection cap securely.
- (4) Fill crankcase with SAE 10W-40 oil (item 40, Appendix E) to upper limit on oil filler cap/dipstick (6) (1.16 qt [1.1 l]).
- (5) Install oil filler cap/dipstick (6).

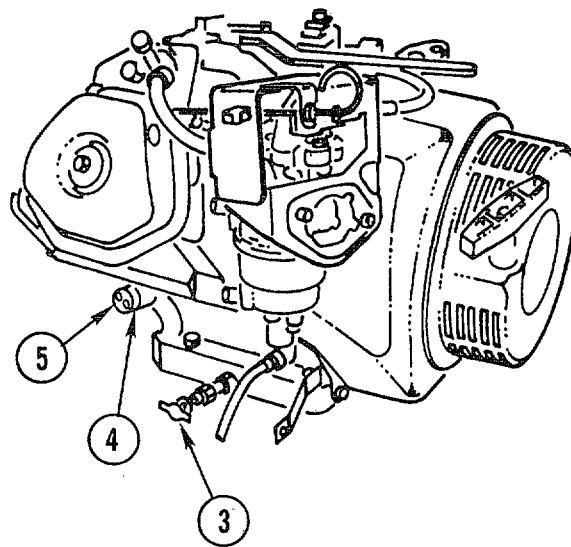
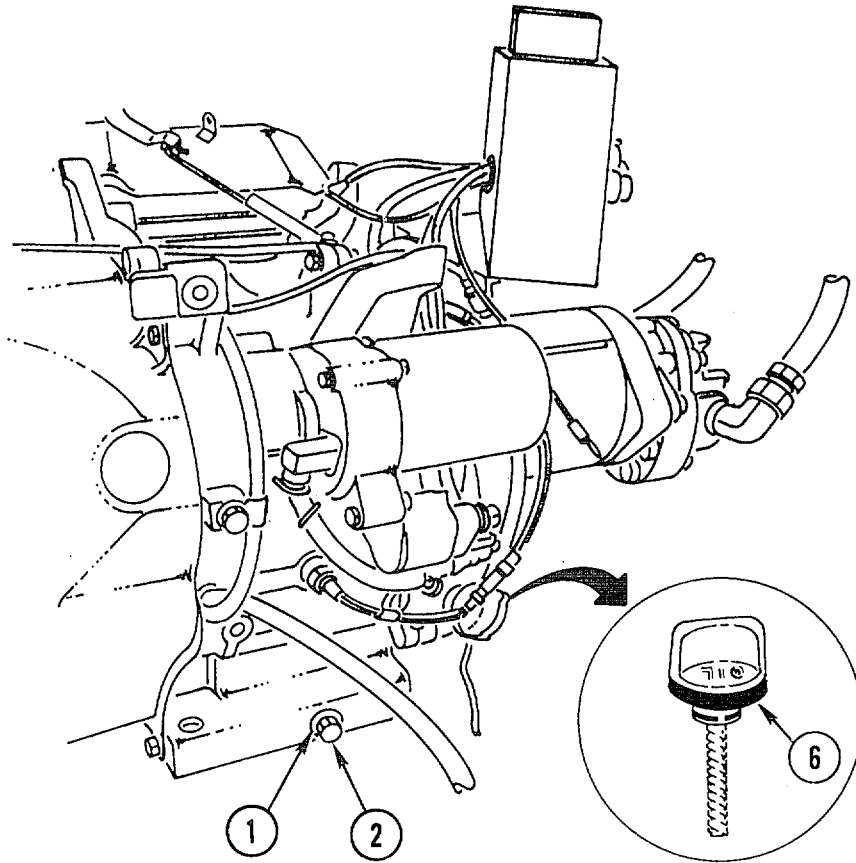

**4-27. HYDRAULIC PUMP ASSEMBLY REPLACEMENT**

---

This task covers:      Removal                      Installation

---

**A. INITIAL SETUP**

**Tools and Special Equipment:**

Tool Kit, 5180-00-177-7033

**Materials/Parts:**

Sealer, Pipe Joint                      Appendix E, Item 56

**Equipment Condition:**

**Reference**

Paragraph 4-34

**Condition Description**

Hydraulic Reservoir  
Drained

---

**B. REMOVAL**

- (1) Loosen clamp (1) and disconnect inlet hydraulic hose (2). Cap open line.
- (2) Disconnect outlet hydraulic hose (3). Cap open line.
- (3) Remove hydraulic pump (4) from engine adapter (5) by removing two bolts (6) and two washers (7).
- (4) Loosen setscrew (8) and remove Lovejoy connector half (9) from pump shaft (10).
- (5) Remove woodruff key (11).
- (6) Remove 90-degree elbow inlet fitting (12).
- (7) Remove straight adapter outlet fitting (13).

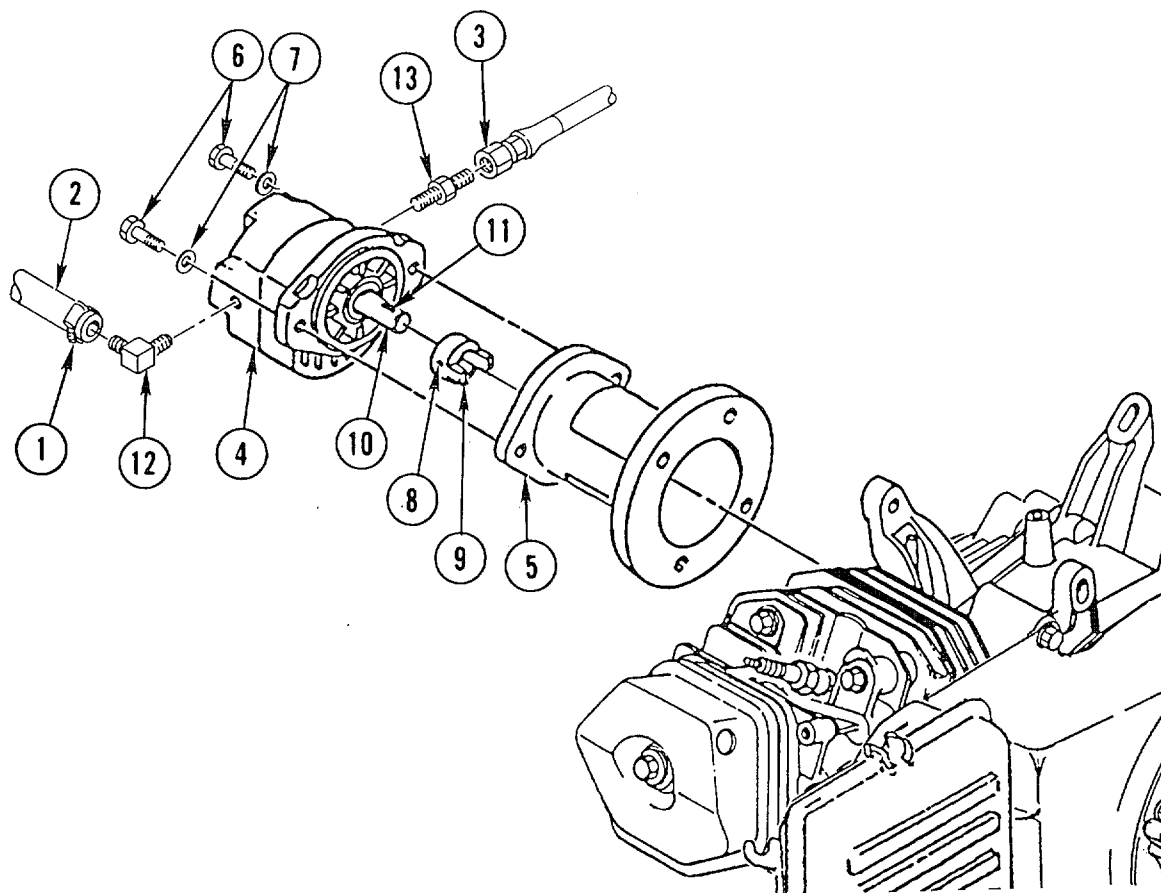

---

**HYDRAULIC PUMP ASSEMBLY REPLACEMENT (CONT)**

---

**C. INSTALLATION**

- (1) Install straight adapter outlet fitting (1).
- (2) Install 90-degree elbow inlet fitting (2).
- (3) Install woodruff key (3) on pump shaft (4).
- (4) Remove engine adapter cover plate (5).
- (5) Place Lovejoy connector half (6) on pump shaft (4) and tighten setscrew (7).
- (6) Insert star (8).
- (7) Align Lovejoy connector half (6) with mating half on engine shaft. Loosen screw on mating half.
- (8) Align hydraulic pump (9) with engine adapter (10) and secure with two washers (11) and two bolts (12).
- (9) Adjust both halves of Lovejoy connector to obtain snug fit. Tighten setscrew (7).
- (10) Install engine adapter cover plate (5).
- (11) Coat hose mating area of fittings (1 and 2) with pipe joint sealer (item 56, Appendix E).
- (12) Remove cap and connect outlet hydraulic hose (13).
- (13) Remove cap and connect inlet hydraulic hose (14).
- (14) Tighten clamp (15).
- (15) Fill hydraulic reservoir.

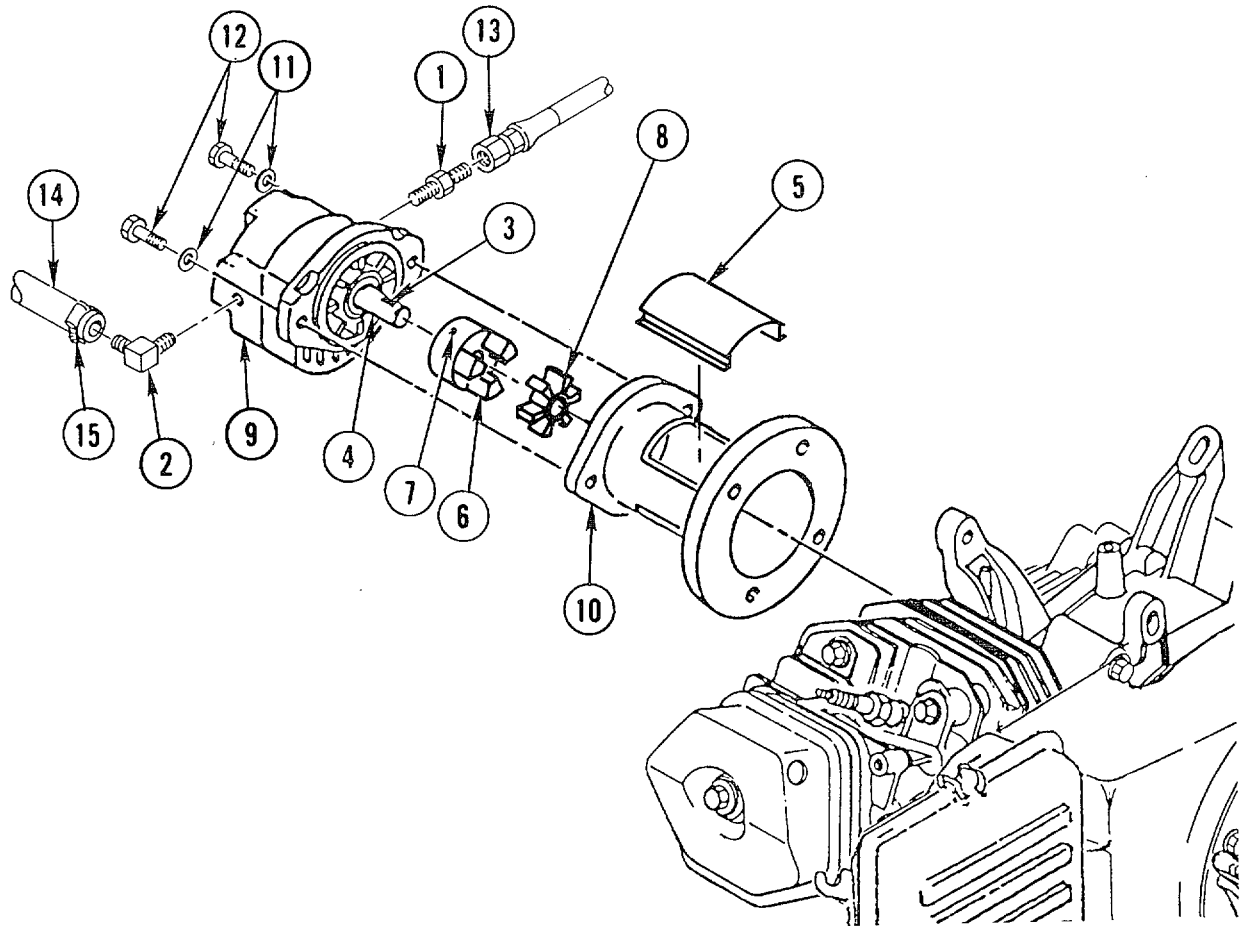



**4-28. GAS TANK ASSEMBLY REPLACEMENT/REPAIR**

---

This task covers:      Removal                      Installation

---

**A. INITIAL SETUP****Tools and Special Equipment:**

Tool Kit, 5180-00-177-7033

**Materials/Parts:**

Sealer, Pipe Joint    Appendix E, Item 56

Sealant, Thread      Appendix E, Item 55

Gasoline, Regular    Appendix E, Item 19

**General Safety Instructions:****WARNING**

Gasoline is flammable. Do not work on fuel system in presence of sparks and open flame. Serious personal injury could result if fuel ignites.

**B. REMOVAL****WARNING**

Gasoline is flammable. Do not work on fuel system in presence of sparks and open flame. Serious personal injury could result if fuel ignites.

**NOTE**

Repair of gas tank assembly consists of replacement of damaged components in accordance with the following procedures.

- (1) Close petcock (1) on fuel strainer (2).
- (2) Place suitable container under fuel strainer (2). Remove strainer bowl (3) by rotating bowl retainer nut (4) counterclockwise.
- (3) Open petcock (1) and drain gasoline into suitable container. Replace strainer bowl (3).
- (4) Disconnect fuel hose (5) from fuel strainer (2). If required, remove male fitting (6) from fuel strainer (2).
- (5) If fuel strainer (2) needs to be replaced, remove strainer from gas tank nipple (7). If required, remove gas tank nipple (7) from gas tank (8).
- (6) If fuel hose (5) does not need to be replaced, proceed to step 10.
- (7) If fuel hose (5) needs to be replaced, remove battery (para 4-33) and air cleaner (para 4-22).

- (8) Remove nut (9), washer (10), and screw (11) from hose clamp (12). Remove hose clamp from fuel hose (5).
- (9) Disconnect fuel hose (5) from carburetor (13) and remove hose.
- (10) Support gas tank (8) and remove two nuts (14), two washers (15), two screws (16), and two washers (15) from bucket leg weldment unions (17). Remove gas tank (8).
- (11) If breather filler cap assembly (18) needs to be replaced, remove six slotted-head screws (19) and remove breather filler cap assembly (18) from gas tank (8).

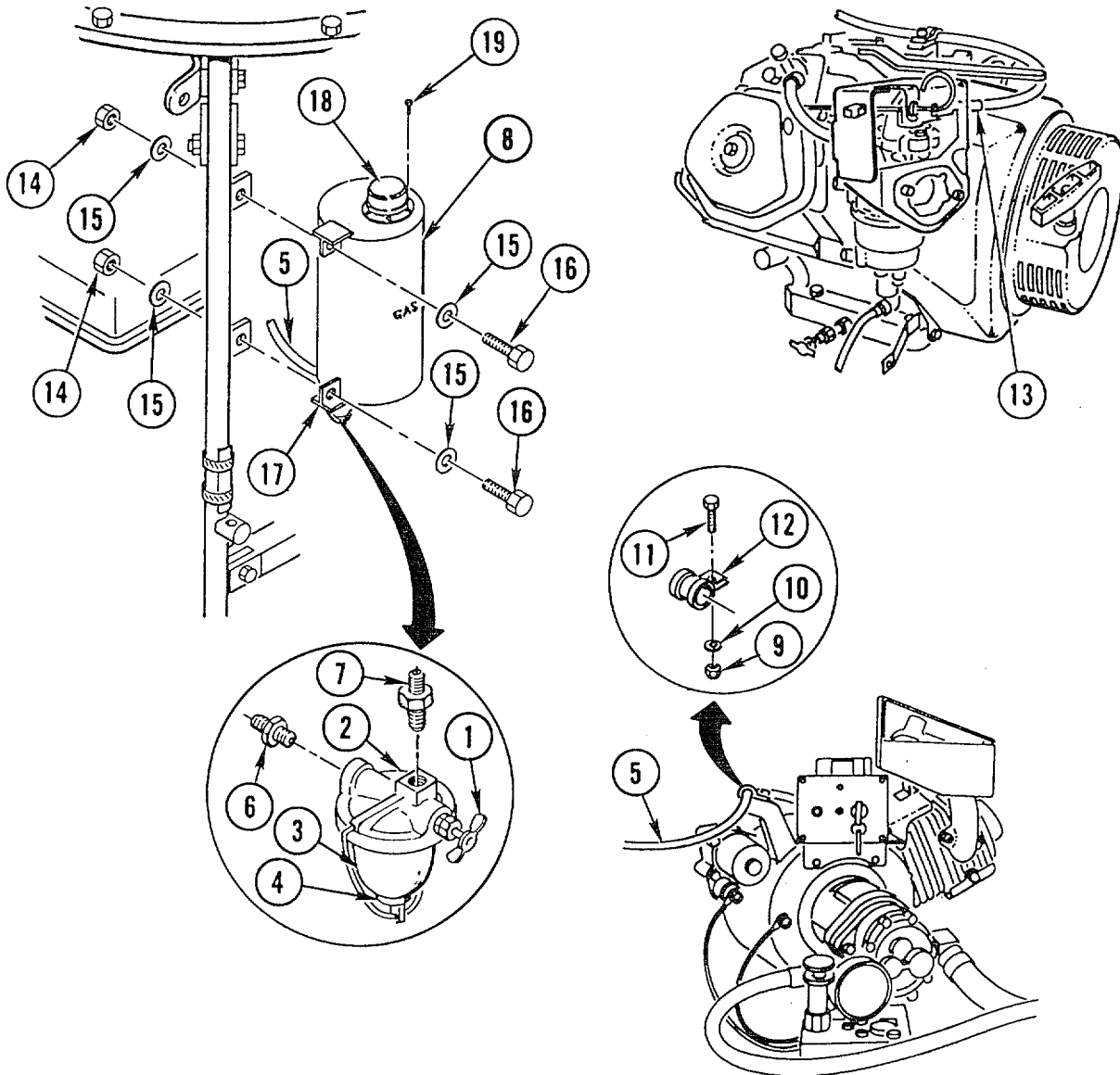

---

**GAS TANK ASSEMBLY REPLACEMENT/REPAIR (CONT)**

---

**C. INSTALLATION****WARNING**

Gasoline is flammable. Do not work on fuel system in presence of sparks and open flame. Serious personal injury could result if fuel ignites.

**NOTE**

Repair of gas tank assembly consists of replacement of damaged components in accordance with the following procedures.

- (1) If breather filler cap assembly (1) was replaced, install breather filler cap assembly on gas tank (2) and secure using six slotted-head screws (3).
- (2) Align gas tank (2) with bucket leg weldment unions (4) and install two washers (5), two screws (6), two washers (5), and two nuts (7).
- (3) If gas tank nipple (8) was replaced, coat all threads of nipple with pipe joint sealer (item 56, Appendix E) and install nipple (8) on gas tank (2).
- (4) Install fuel strainer (9) on gas tank nipple (8).
- (5) If male fitting (10) was replaced, coat all threads of fitting with thread sealant (item 55, Appendix E) and install in fuel strainer (9).
- (6) If fuel hose (11) was not replaced, proceed to step 10.
- (7) If fuel hose (11) was replaced, connect new fuel hose (11) to carburetor (12).
- (8) Install hose clamp (13) on new fuel hose and align clamp on engine. Secure using screw (14), washer (15), and nut (16).
- (9) Install battery (para 4-33) and air cleaner (para 4-22).
- (10) Connect fuel hose (11) to threads of male fitting (10).
- (11) If required, install strainer bowl (17) on fuel strainer (9) and tighten bowl retainer nut (18).
- (12) Close petcock (19).
- (13) Fill gas tank (2) with gasoline (item 19, Appendix E) and check for leaks.

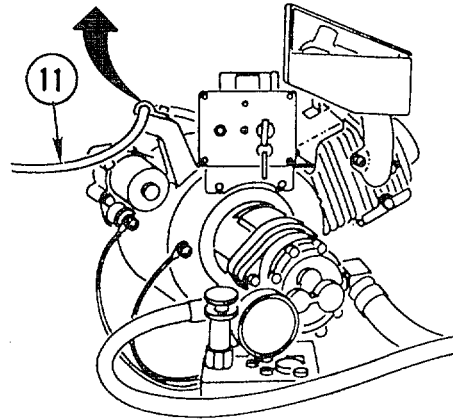
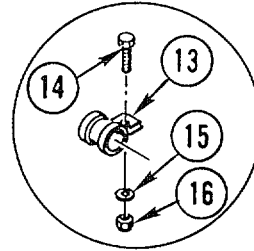
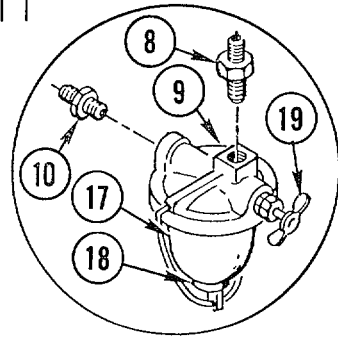
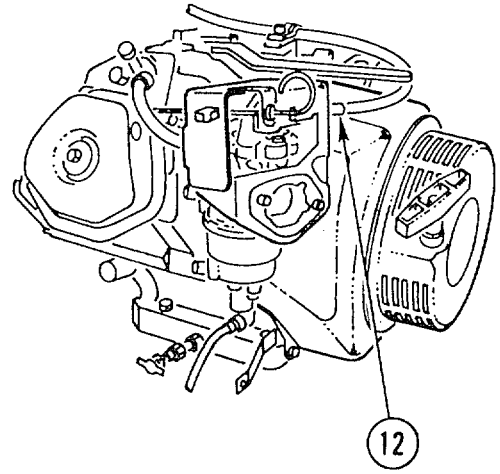
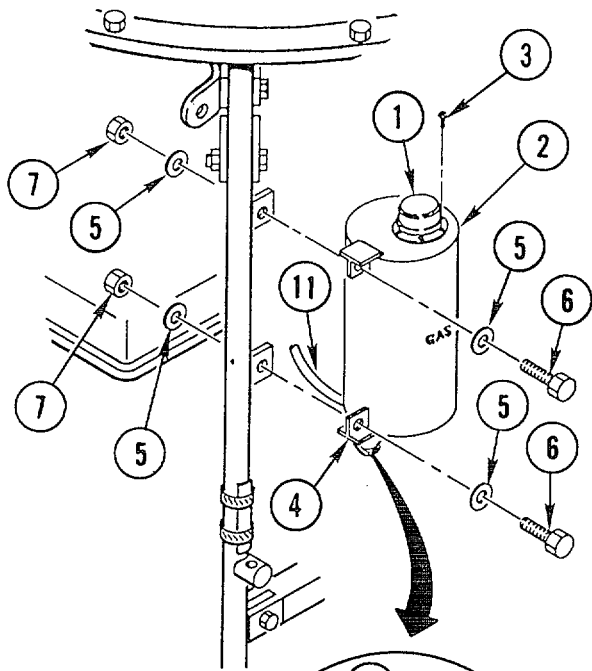

**4-29. BATTERY/HYDRAULIC ASSEMBLY REPLACEMENT**

---

This task covers:      Removal                      Installation

---

**A. INITIAL SETUP**

**Tools and Special Equipment:**

Tool Kit, 5180-00-177-7033

**Personnel Required:** (2)

**Equipment Condition:**

<b>Reference</b>	<b>Condition Description</b>
Paragraph 4-19	Engine Removed

**General Safety Instructions:**

**WARNING**

Battery/hydraulic assembly is very heavy. Use two persons when lifting or moving assembly to prevent personal injury.

**B. REMOVAL**

- (1) Remove battery (1) (para 4-33).
- (2) Disconnect two hydraulic hoses from inlet (2) and outlet (3) 90-degree elbow fittings. Cap open hydraulic lines.
- (3) Remove electrical leads (4) from secondary hydraulic manifold 12 VDC coil (5).
- (4) Support battery/hydraulic assembly (6) and remove four nuts (7), four washers (8), four bolts (9), and four washers (8) from two side supports (10) at four bucket leg weldment unions (11).

**WARNING**

Battery/hydraulic assembly is very heavy. Use two persons when lifting or moving assembly to prevent personal injury.

- (5) Using two persons, lift battery/hydraulic assembly (6) until side supports (10) clear all four bucket leg weldment unions (11) and remove battery/hydraulic assembly (6).

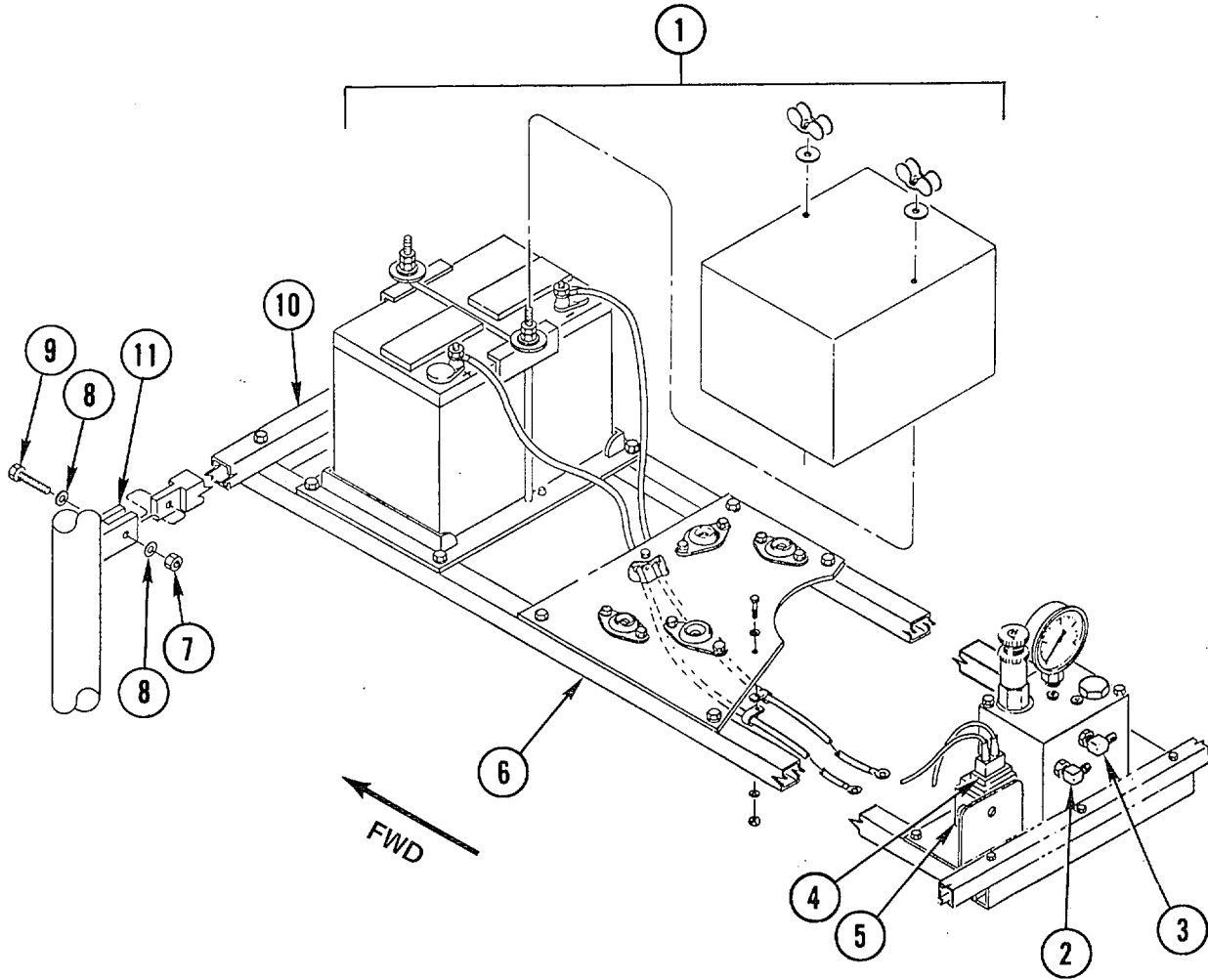

**BATTERY/HYDRAULIC ASSEMBLY REPLACEMENT (CONT)****C. INSTALLATION****WARNING**

Battery/hydraulic assembly is very heavy. Use two persons when lifting or moving assembly to prevent personal injury.

- (1) Using two persons, install battery/hydraulic assembly (1) with secondary hydraulic manifold toward rear of bucket assembly.
- (2) Align two side supports (2) with four bucket leg weldment unions (3) and install four washers (4), four bolts (5), four washers (4), and four nuts (6).
- (3) Connect electrical leads (7) to secondary hydraulic manifold 12 VDC coil (8).
- (4) Remove cap and connect return hydraulic hose to outlet 90-degree elbow fitting (9).
- (5) Remove cap and connect pressure hose from primary hydraulic manifold to inlet 90-degree elbow fitting (10).
- (6) Install battery (11) (para 4-33).

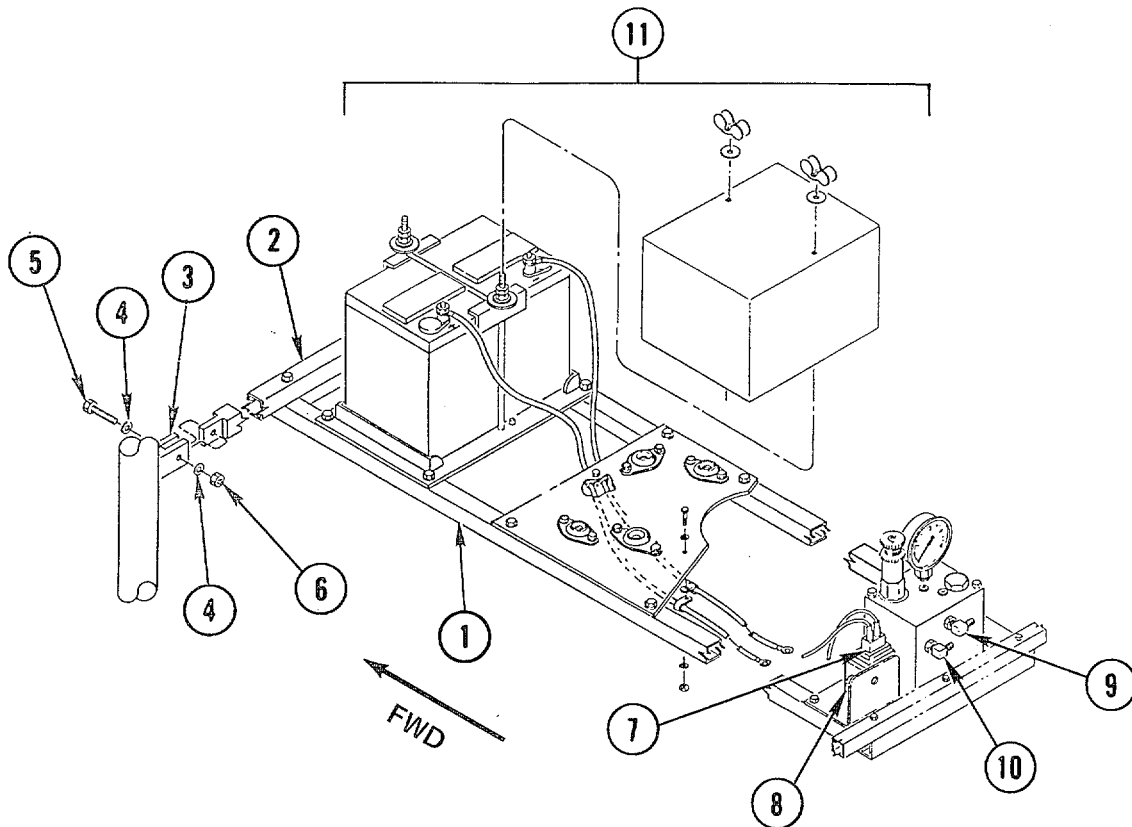

**4-30. ALL ANGLE ISOLATOR REPLACEMENT**

This task covers:      Removal                  Installation

**A. INITIAL SETUP**

**Tools and Special Equipment:**

Tool Kit, 5180-00-177-7033

**Equipment Condition:**

**Reference**

Paragraph 4-19

**Condition Description**

Engine and Pump  
Assembly Removed

**B. REMOVAL**

Remove each all angle isolator (1) from engine plate (2) by removing two nuts (3), four washers (4), and two bolts (5).

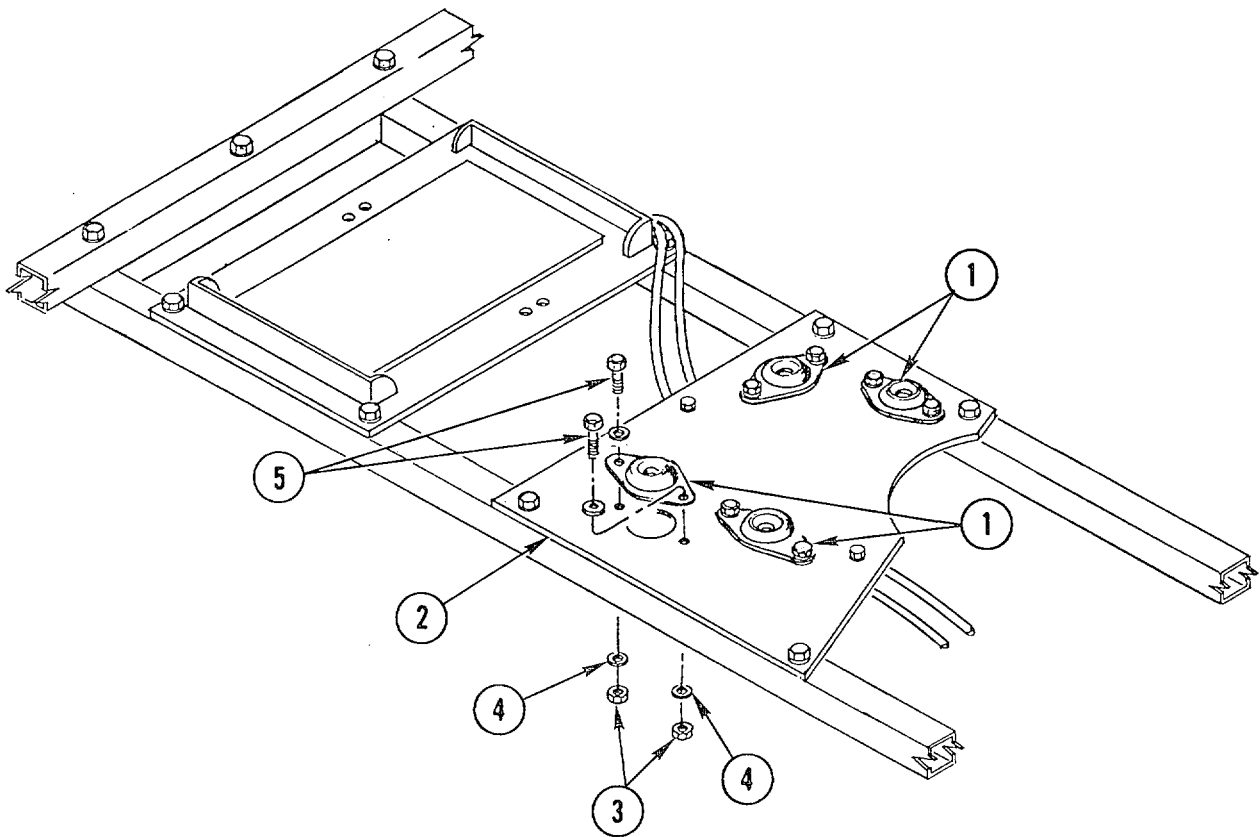

**C. INSTALLATION**

Align each all angle isolator (1) on engine plate (2) and install two bolts (5), four washers (4), and two nuts (3).



**4-31. BATTERY CABLE REPLACEMENT**

---

This task covers:      Removal                      Installation

---

**A. INITIAL SETUP**

**Tools and Special Equipment:**

Tool Kit, 5180-00-177-7033

**General Safety Instructions:**

**WARNING**

**Equipment Condition:**

All electrical switches must be OFF before disconnecting or connecting battery cables. Shorting or arcing could cause serious burns.

<b>Reference</b>	<b>Condition Description</b>
Paragraph 4-33	Battery Cover Weldment Removed

---

**B. REMOVAL**

**WARNING**

All electrical switches must be OFF before disconnecting battery cables. Shorting or arcing could cause serious burns.

- (1) Disconnect two battery cables (1) from battery (2) by removing two locknuts (3).
- (2) Disconnect positive cable connection (4) from starter solenoid (5).
- (3) Disconnect ground cable connection (6) from engine (7).
- (4) Remove four adel clamps (8) from underside of engine mounting plate (9) by removing two nuts (10), four washers (11), and two bolts (12).

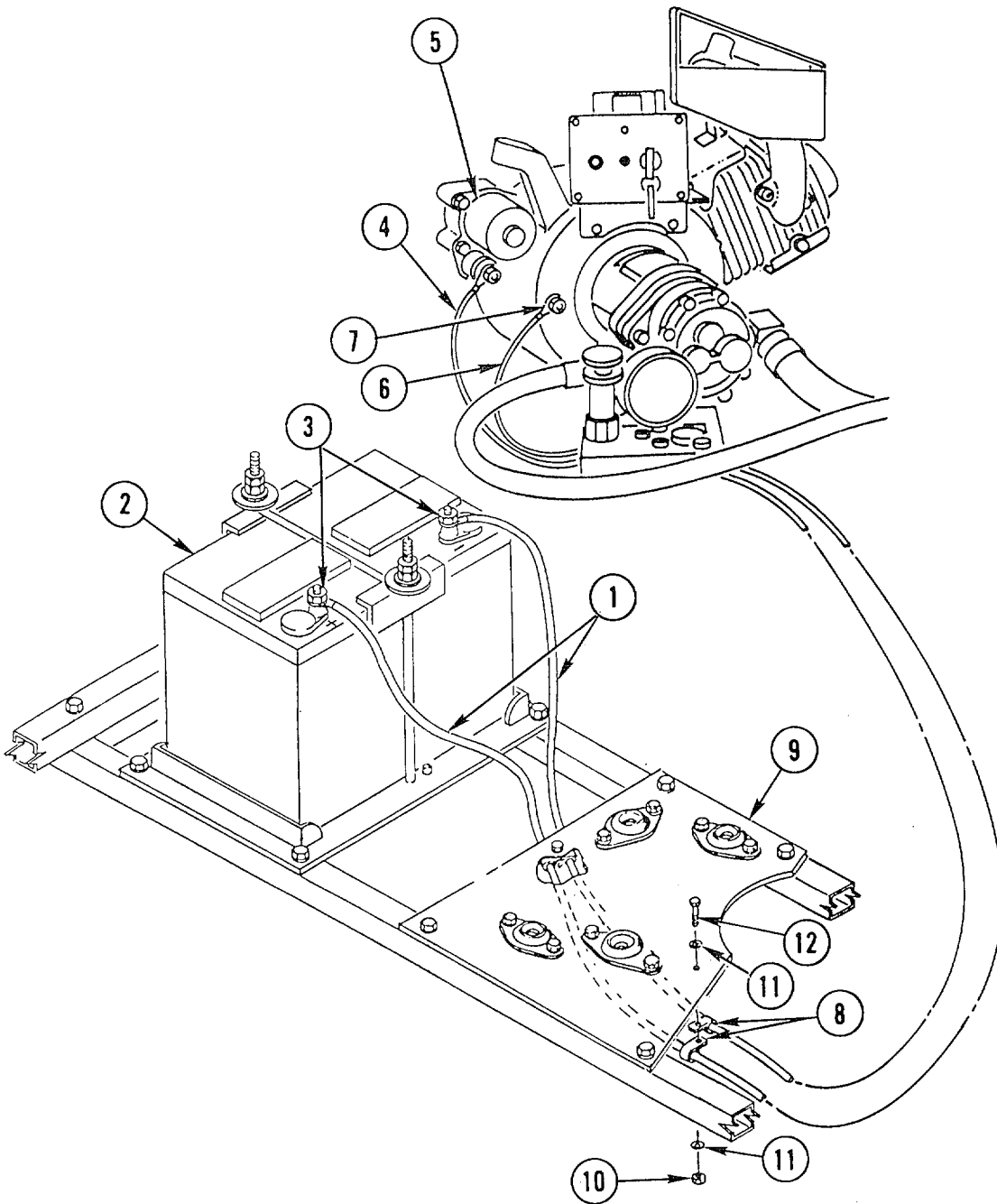

---

**BATTERY CABLE REPLACEMENT (CONT)**

---

**C. INSTALLATION**

- (1) Install four adel clamps (1) on underside of engine mounting plate (2) by installing two bolts (3), four washers (4), and two nuts (5).
- (2) Connect ground cable connection (6) to engine (7).
- (3) Connect positive cable connection (8) to starter solenoid (9).

**WARNING**

All electrical switches must be OFF before connecting battery cables. Shorting or arcing could cause serious burns.

- (4) Connect two battery cables (10) to battery (11) by installing two locknuts (12). Connect positive battery cable (red) to positive battery terminal (+). Connect negative battery cable (black) to negative battery terminal (-).

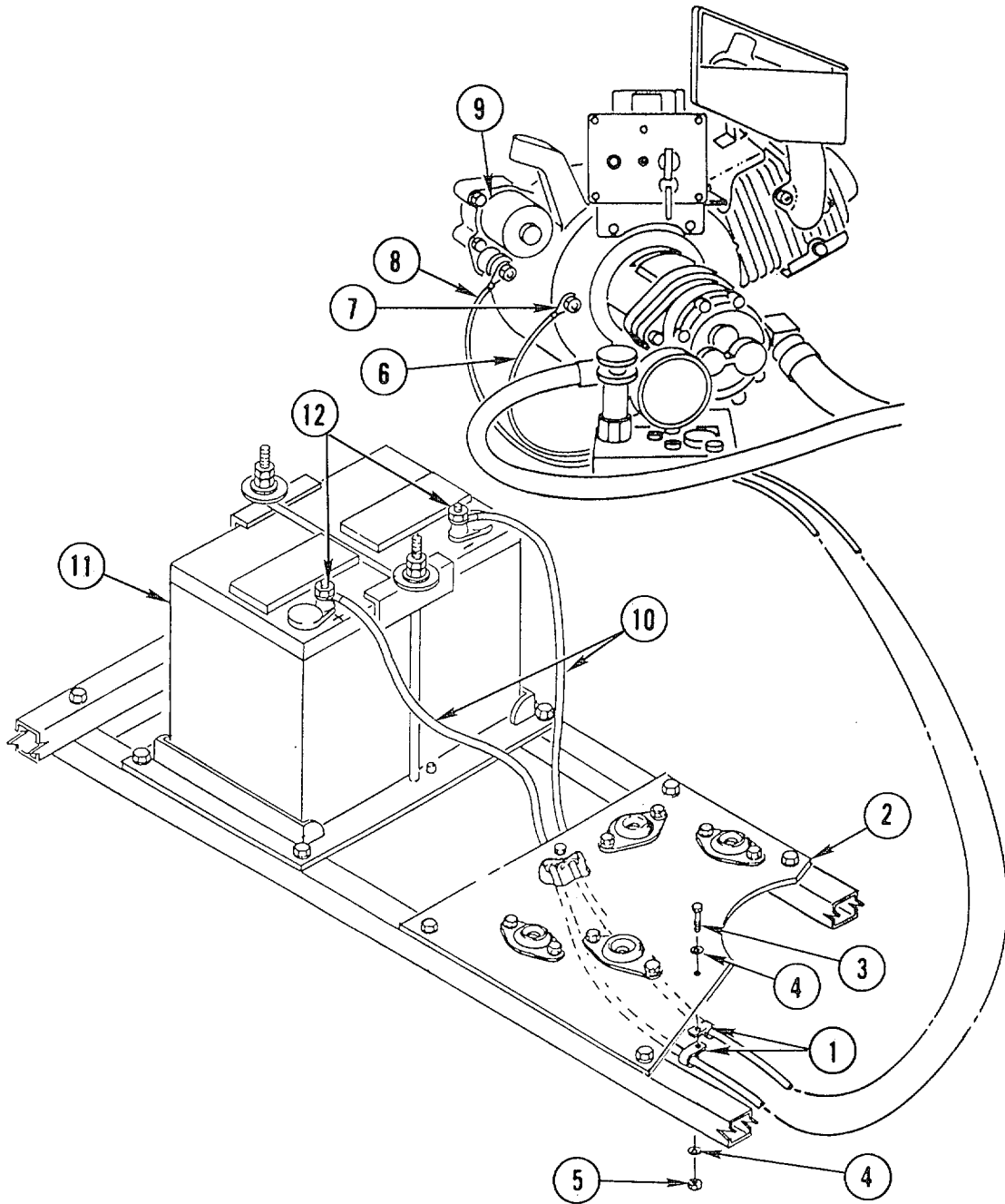

**4-32. SECONDARY HYDRAULIC MANIFOLD ASSEMBLY REPLACEMENT**

This task covers:      Removal                      Installation

**A. INITIAL SETUP**

**Tools and Special Equipment:**

Tool Kit, 5180-00-177-7033

**Equipment Condition:**

**Reference**

Paragraph 4-34

**Condition Description**

Hydraulic Reservoir  
Drained

**B. REMOVAL**

- (1) Remove electrical leads (1) from secondary hydraulic manifold 12 VDC coil (2).
- (2) Disconnect two hydraulic hoses from two quick-release fittings (3). Cap fittings (3) with two attached dust caps (4). Cap open hydraulic lines.
- (3) Disconnect two hydraulic hoses from inlet (5) and outlet (6) 90-degree elbow fittings. Cap open hydraulic lines.
- (4) Remove secondary hydraulic manifold assembly (7) from mounting platform (8) by removing two nuts (9), four washers (10), and two holddown bolts (11).

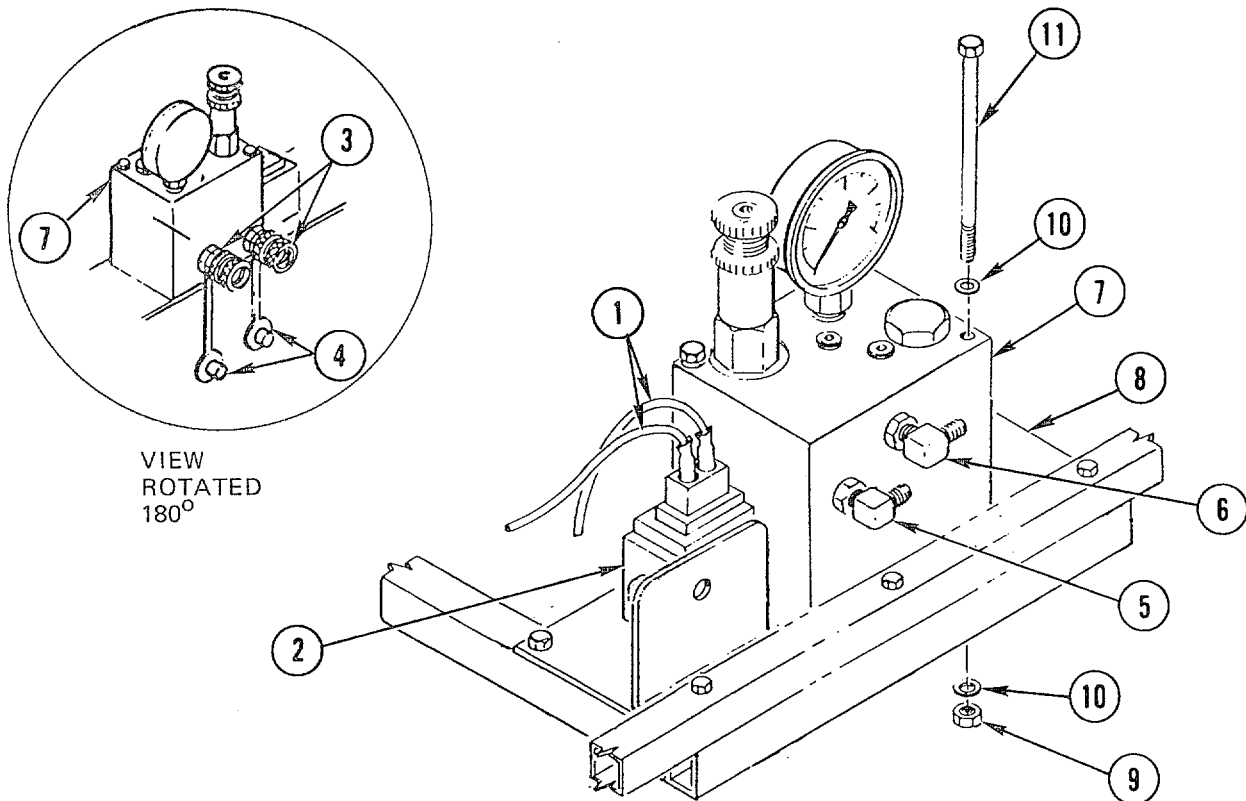

VIEW  
ROTATED  
180°

**C. INSTALLATION**

- (1) Align secondary hydraulic manifold assembly (1) on mounting platform (2) and secure with two holddown bolts (3), four washers (4), and two nuts (5).
- (2) Remove cap and connect outlet hydraulic hose to outlet 90-degree elbow fitting (6).
- (3) Remove cap and connect inlet hydraulic hose from primary hydraulic manifold to inlet 90-degree elbow fitting (7).
- (4) Remove two dust caps (8) from two quick-release fittings (9) and remove caps from hydraulic hoses. Connect hydraulic hoses to two quick-release fittings (9) matching markings on hoses with markings on manifold (A to A and B to B).
- (5) Connect electrical leads (10) to secondary hydraulic manifold 12 VDC coil (11).

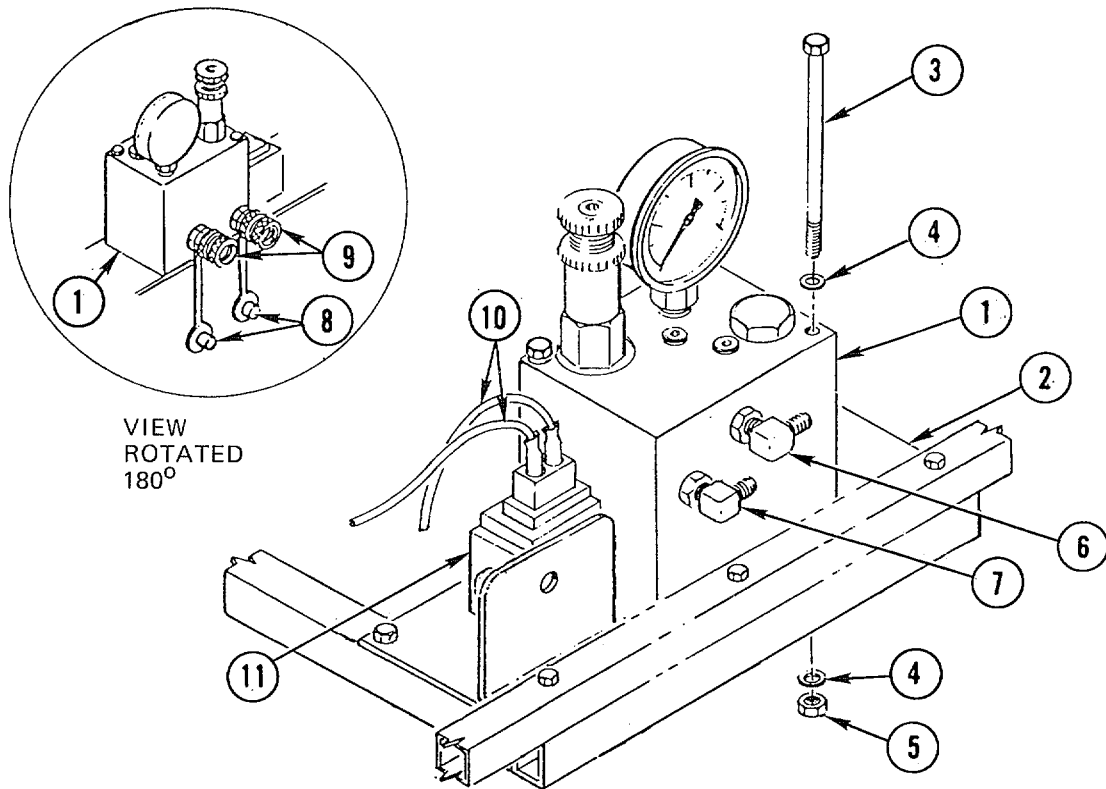

**4-33. BATTERY ASSEMBLY REPLACEMENT**

---

This task covers:      Removal                      Installation

---

**A. INITIAL SETUP****Tools and Special Equipment:**

Tool Kit, 5180-00-177-7033

**General Safety Instructions:****WARNING**

All electrical switches must be OFF before disconnecting or connecting battery cables. Shorting or arcing could cause serious burns.

Battery electrolyte is an acid, and is highly corrosive. Wear rubber gloves, face shield, and apron. Do not spill on clothing, skin, or PDU. Wash exposed areas with water. Seek medical assistance. Failure to do so could result in personal injury.

**B. REMOVAL****WARNING**

All electrical switches must be OFF before disconnecting battery cables. Shorting or arcing could cause serious burns.

Battery electrolyte is an acid, and is highly corrosive. Wear rubber gloves, face shield, and apron. Do not spill on clothing, skin, or PDU. Wash exposed areas with water. Seek medical assistance. Failure to do so could result in personal injury.

- (1) Remove two wing nuts (1) and two washers (2) from battery cover weldment (3). Remove cover weldment.
- (2) Disconnect two battery cables (4) from battery (5) by removing two locknuts (6).
- (3) Remove four jam nuts (7), two insulator washers (8), and two flat washers (9) from two holddown bolts (10).
- (4) Remove holddown crossbar (11) and two holddown bolts (10). Remove battery (5) from battery pad (12).

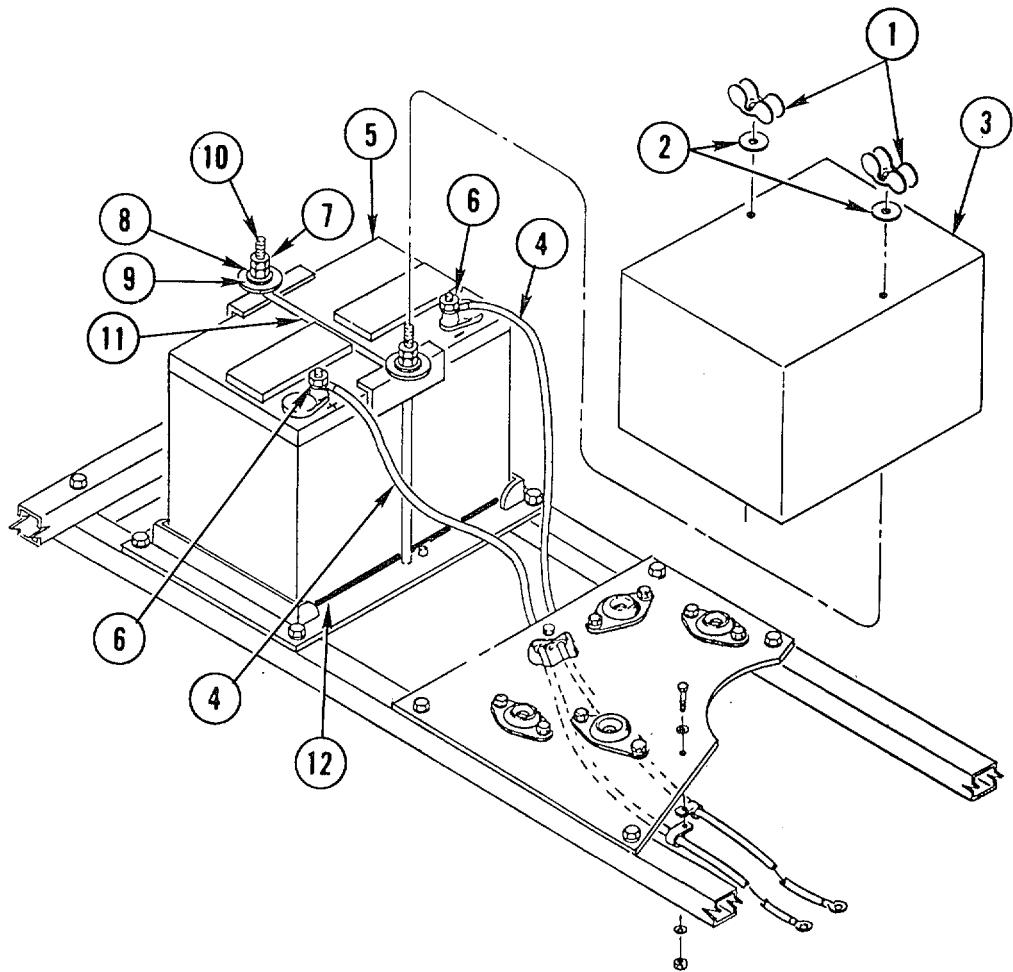





---

**BATTERY ASSEMBLY REPLACEMENT (CONT)**

---

**C. INSTALLATION****WARNING**

All electrical switches must be OFF before connecting battery cables. Shorting or arcing could cause serious burns.

Battery electrolyte is an acid, and is highly corrosive. Wear rubber gloves, face shield, and apron. Do not spill on clothing, skin, or PDU. Wash exposed areas with water. Seek medical assistance. Failure to do so could result in personal injury.

- (1) Place battery (1) on battery pad (2).
- (2) Hook two holddown bolts (3) on battery pad (2) and install holddown crossbar (4).
- (3) Install two flat washers (5), two insulator washers (6), and four jam nuts (7) on two holddown bolts (3).

**NOTE**

Positive (red) cable goes to (+) terminal. Negative (black) cable goes to (-) terminal.

- (4) Connect two battery cables (8) to battery (1) according to color-coding, and secure with two locknuts (9).
- (5) Install battery cover weldment (10).
- (6) Install two washers (11) and two wing nuts (12).

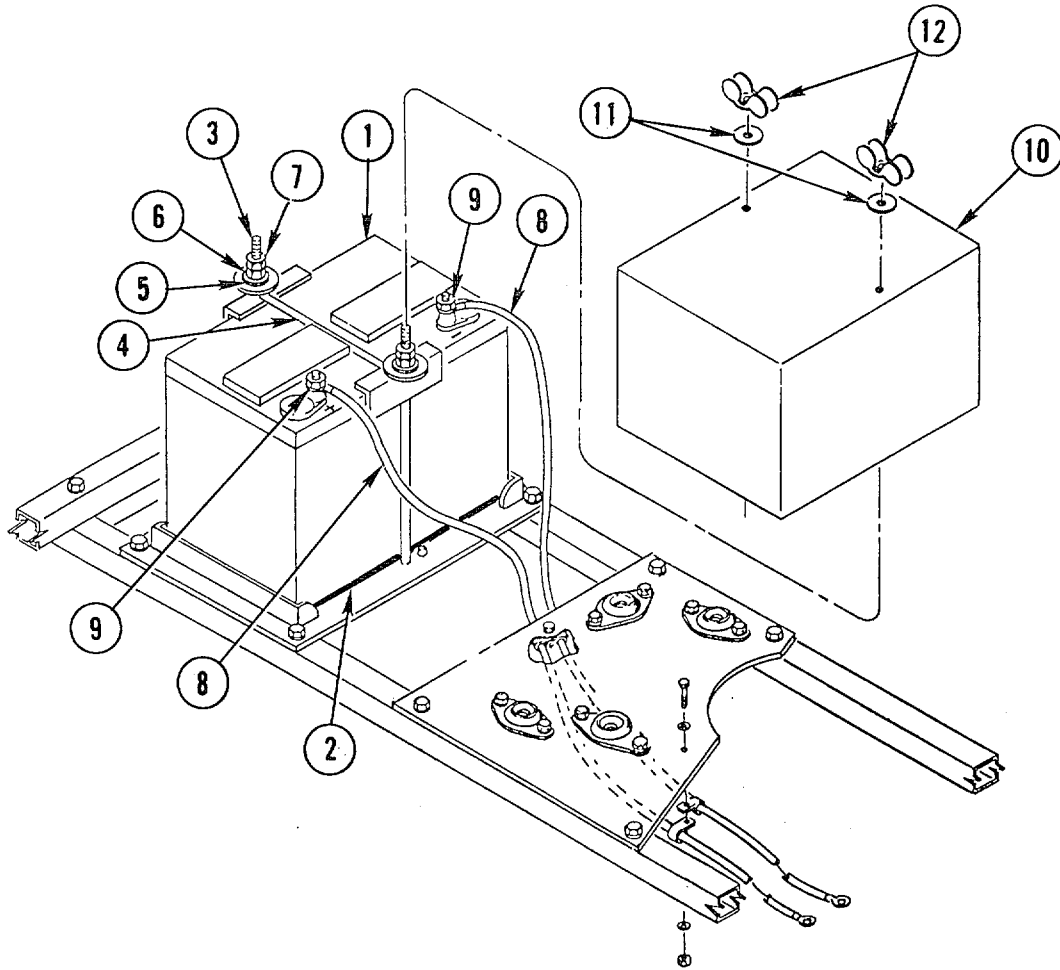

**4-34. HYDRAULIC RESERVOIR PRIMARY MANIFOLD ASSEMBLY REPLACEMENT**

---

 This task covers:    Removal            Installation
 

---

**A. INITIAL SETUP****Tools and Special Equipment:****Materials/Parts**

Tool Kit, 5180-00-177-7033

Fluid, Hydraulic

Appendix E, Item 10

**B. REMOVAL**

- (1) Place suitable container under gate valve drain tube (1). Turn gate valve (2) counterclockwise and drain fluid from hydraulic reservoir.
- (2) Disconnect three hydraulic hoses (3) from primary manifold fittings. Cap open hydraulic lines and fittings.
- (3) Disconnect two electrical leads (4) from primary manifold 12 V coil (5).
- (4) Disconnect quick-disconnect hydraulic hose(6) from filter (7). Cap open hydraulic line.
- (5) Disconnect hydraulic hose (8) from filter (7). Cap open hydraulic line.
- (6) Loosen clamp (9) and remove hose (10). Cap open line.
- (7) Remove hydraulic reservoir primary manifold assembly (11) from bucket weldment unions (12) by removing two nuts (13), two bolts (14), and four washers (15).

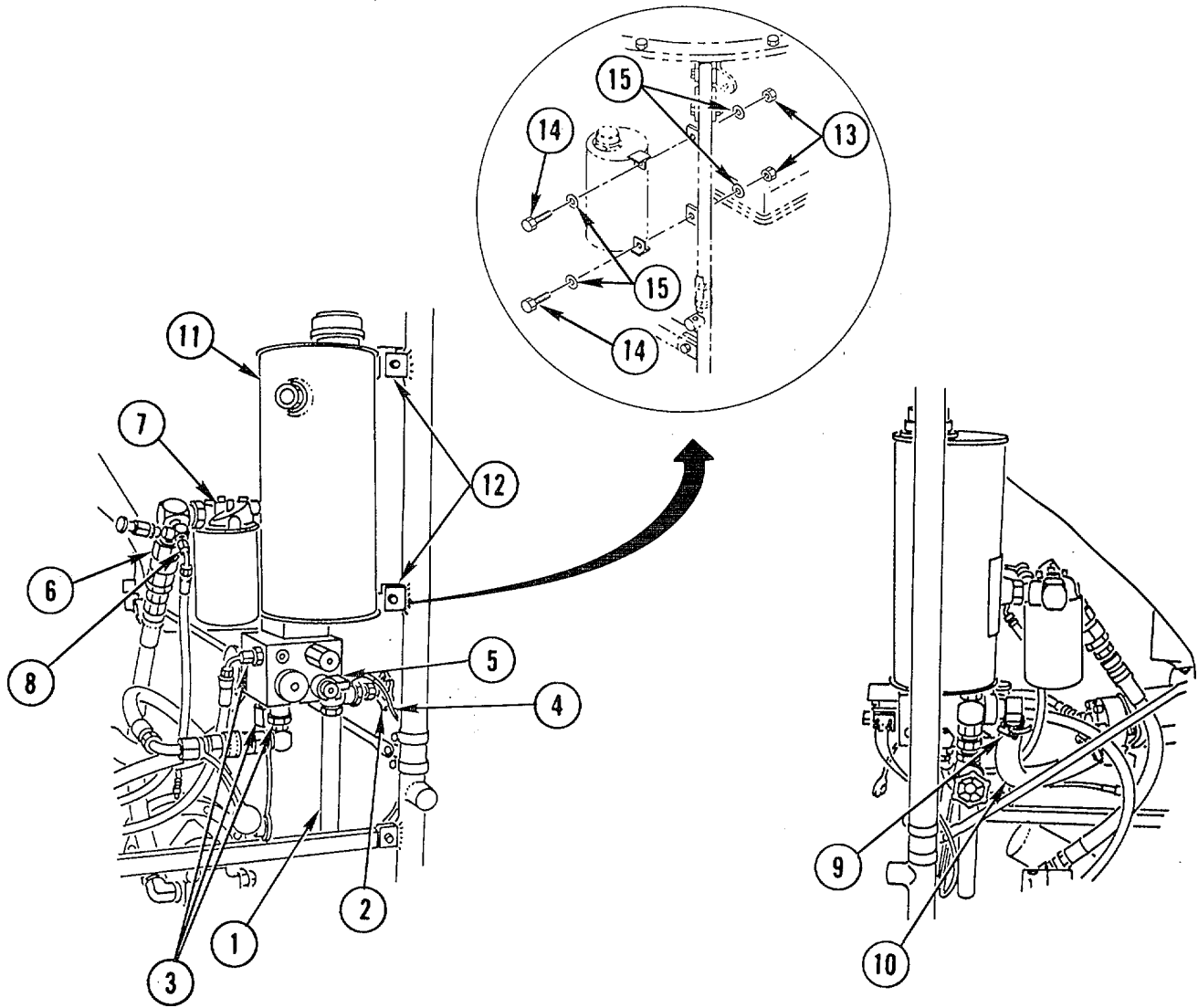

**HYDRAULIC RESERVOIR PRIMARY MANIFOLD ASSEMBLY REPLACEMENT (CONT)**

**C. INSTALLATION**

- (1) Align hydraulic reservoir primary manifold assembly (1) on bucket weldment unions (2) and secure with four washers (3), two bolts (4), and two nuts (5).
- (2) Remove cap and connect hose (6).
- (3) Tighten clamp (7).
- (4) Remove cap and connect quick-disconnect hydraulic hose (8) to filter (9).
- (5) Remove cap and connect hydraulic hose (10) to filter (9).
- (6) Connect two electrical leads (11) to primary manifold 12 V coil (12).
- (7) Remove caps and connect three hydraulic hoses (13) to primary manifold fittings.
- (8) Make sure gate valve (14) is closed. Fill hydraulic reservoir with hydraulic fluid (item 10, Appendix E).

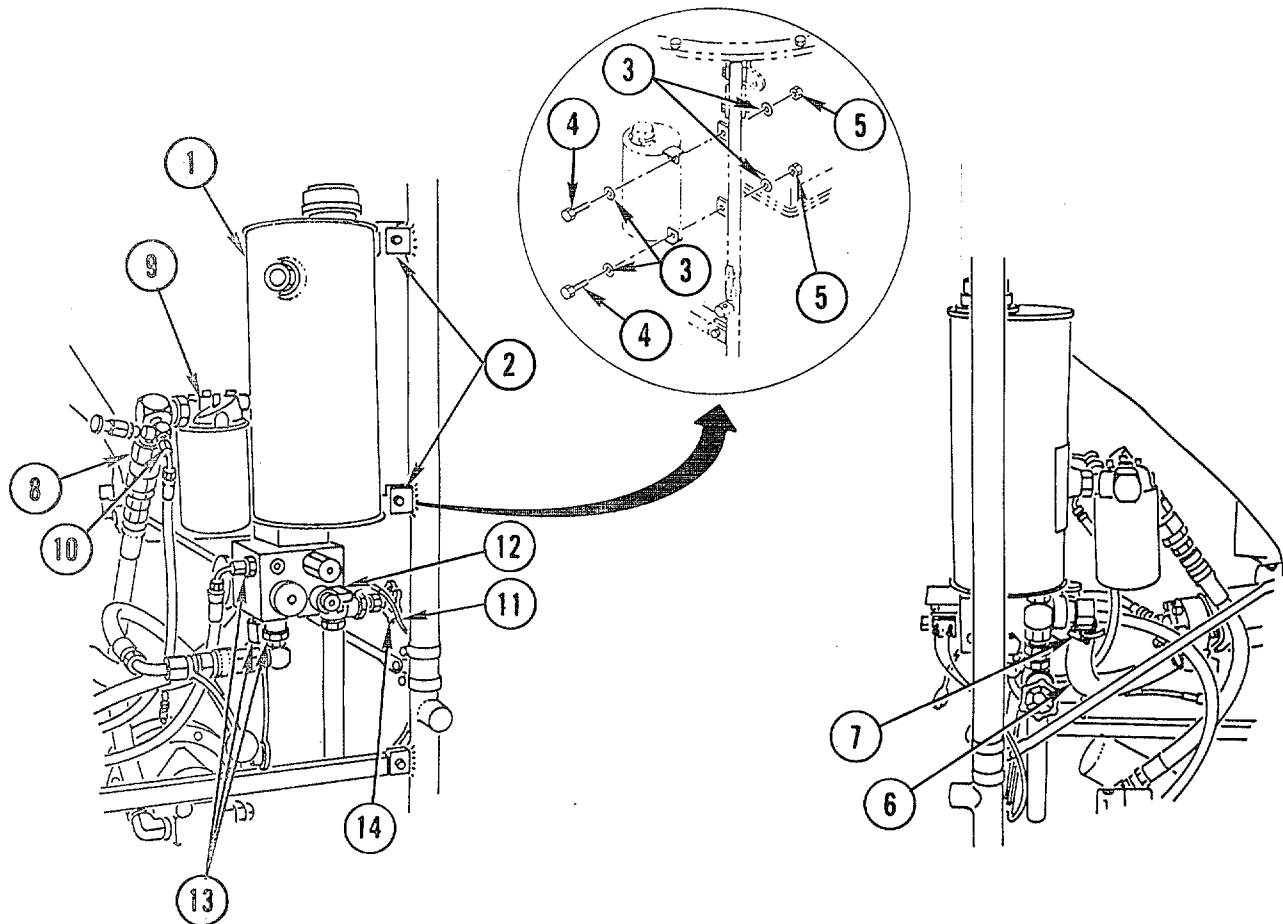

**4-35. HYDRAULIC RESERVOIR PRIMARY MANIFOLD ASSEMBLY REPAIR**

This task covers: Disassembly Assembly

---

**A. INITIAL SETUP**

**Tools and Special Equipment:**

Tool Kit, 5180-00-177-7033

**Equipment Condition:**

**Reference**

Paragraph 4-34

**Condition Description**

Hydraulic Reservoir  
Primary Manifold  
Assembly Removed

**Materials/Parts:**

O-Ring                                      Appendix E, Item 42

Filter, 10-Micron                      Appendix E, Item 8

Sealer, Pipe Joint                      Appendix E, Item 56

---

**HYDRAULIC RESERVOIR PRIMARY MANIFOLD ASSEMBLY REPAIR (CONT)**

---

**B. DISASSEMBLY**

- (1) Remove primary manifold (1) from hydraulic tank mounting studs (2) by removing four nuts (3) and four washers (4).
- (2) Remove and discard O-ring (5).
- (3) Remove fitting (6) from 10-micron filter housing assembly (7).
- (4) Remove and discard 10-micron filter (8) from filter housing assembly (7). Remove filter housing assembly from fitting (9).
- (5) Remove fitting (10) from reservoir tank (11).
- (6) Remove drain pipe (12) from brass gate valve (13).
- (7) Remove brass gate valve (13) from fitting (14).
- (8) Remove fittings (14 and 15) from reservoir tank (11).
- (9) Remove reservoir sight gage (16).
- (10) Remove reservoir filler breather cap (17) and remove six slotted-head screws (18).
- (11) Remove plug (19).



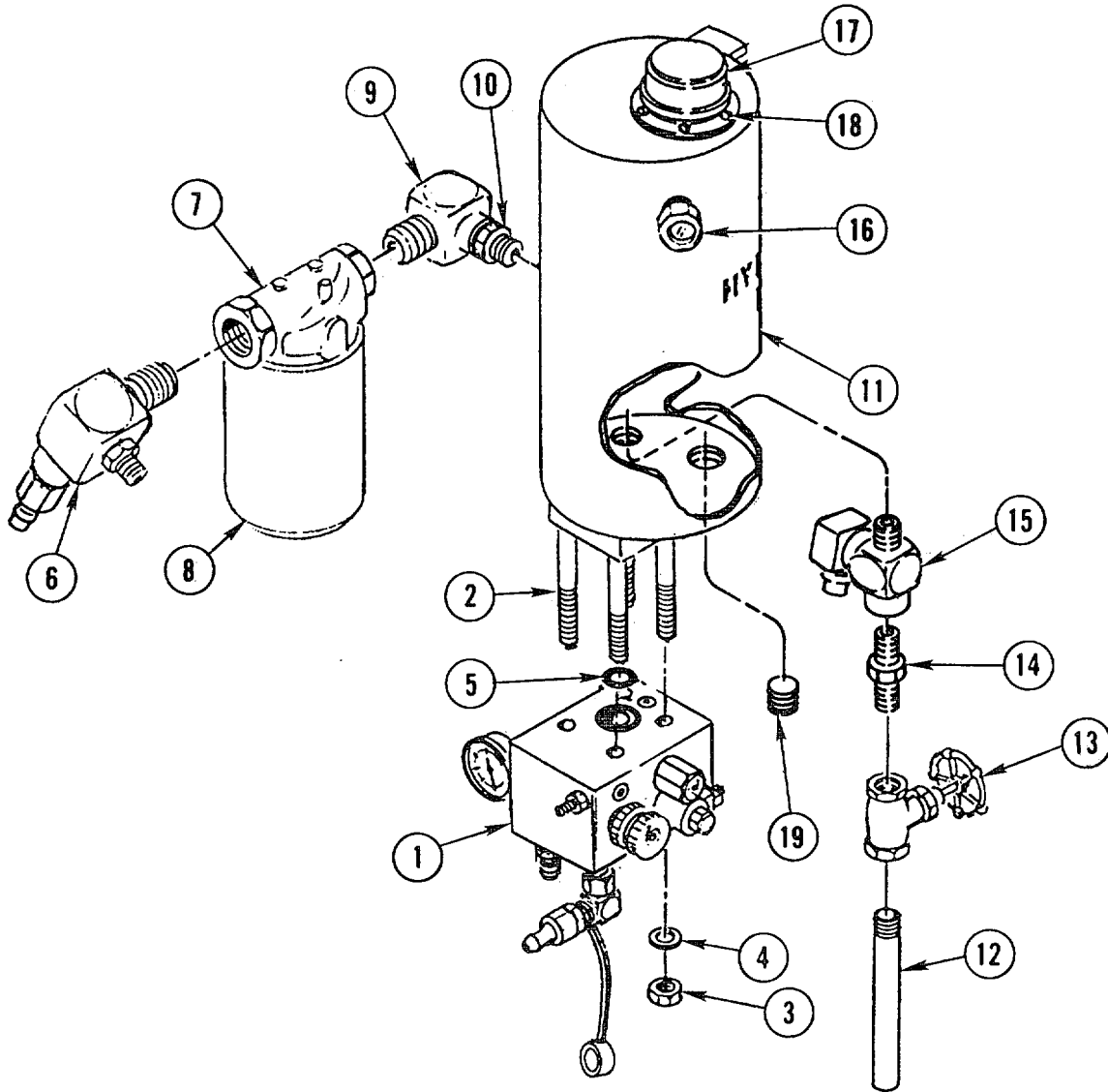

---

**HYDRAULIC RESERVOIR PRIMARY MANIFOLD ASSEMBLY REPAIR (CONT)**

---

**C. ASSEMBLY**

- (1) Install reservoir filler breather cap (1) and six slotted-head screws (2).
- (2) Apply pipe joint sealer (item 56, Appendix E) to threads and install reservoir sight gage (3).
- (3) Apply pipe joint sealer (item 56, Appendix E) to threads and install fittings (4 and 5) on reservoir tank (6).
- (4) Apply pipe joint sealer (item 56, Appendix E) to threads and install brass gate valve (7) on fitting (4).
- (5) Apply pipe joint sealer (item 56, Appendix E) to threads and install drain pipe (8) on brass gate valve (7).
- (6) Apply pipe joint sealer (item 56, Appendix E) to threads and install fitting (9) on reservoir tank(6).
- (7) Apply pipe joint sealer (item 56, Appendix E) to threads and install filter housing (10) on fitting (11).
- (8) Apply pipe joint sealer (item 56, Appendix E) to threads and install fitting (12) on filter housing (10).
- (9) Install new 10-micron filter (13) on filter housing (10).
- (10) Install new O-ring (14) in primary manifold (15).
- (11) Align primary manifold (15) with hydraulic tank mounting studs (16) and secure with four washers (17) and four nuts (18).
- (12) Install plug (19).

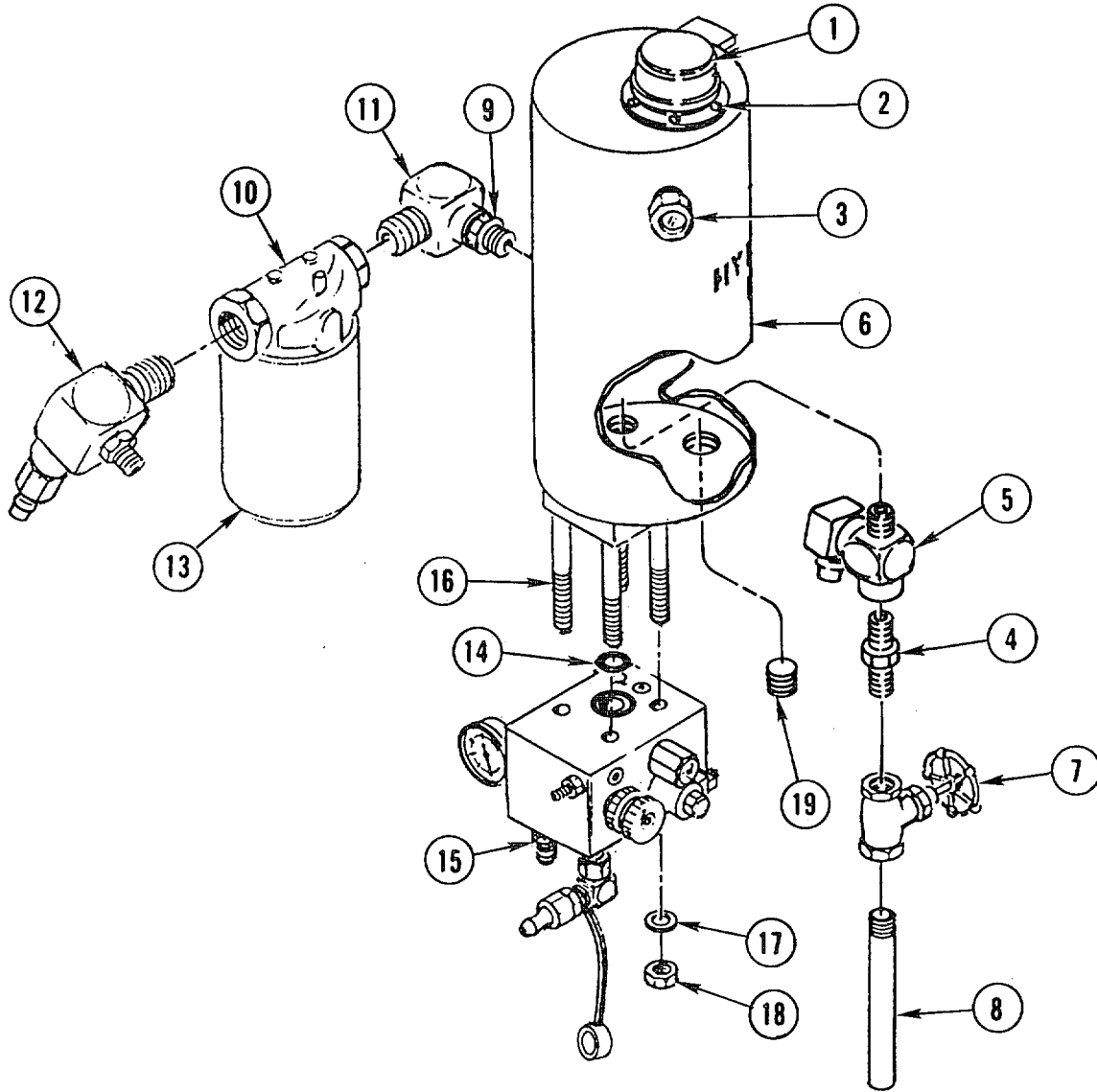



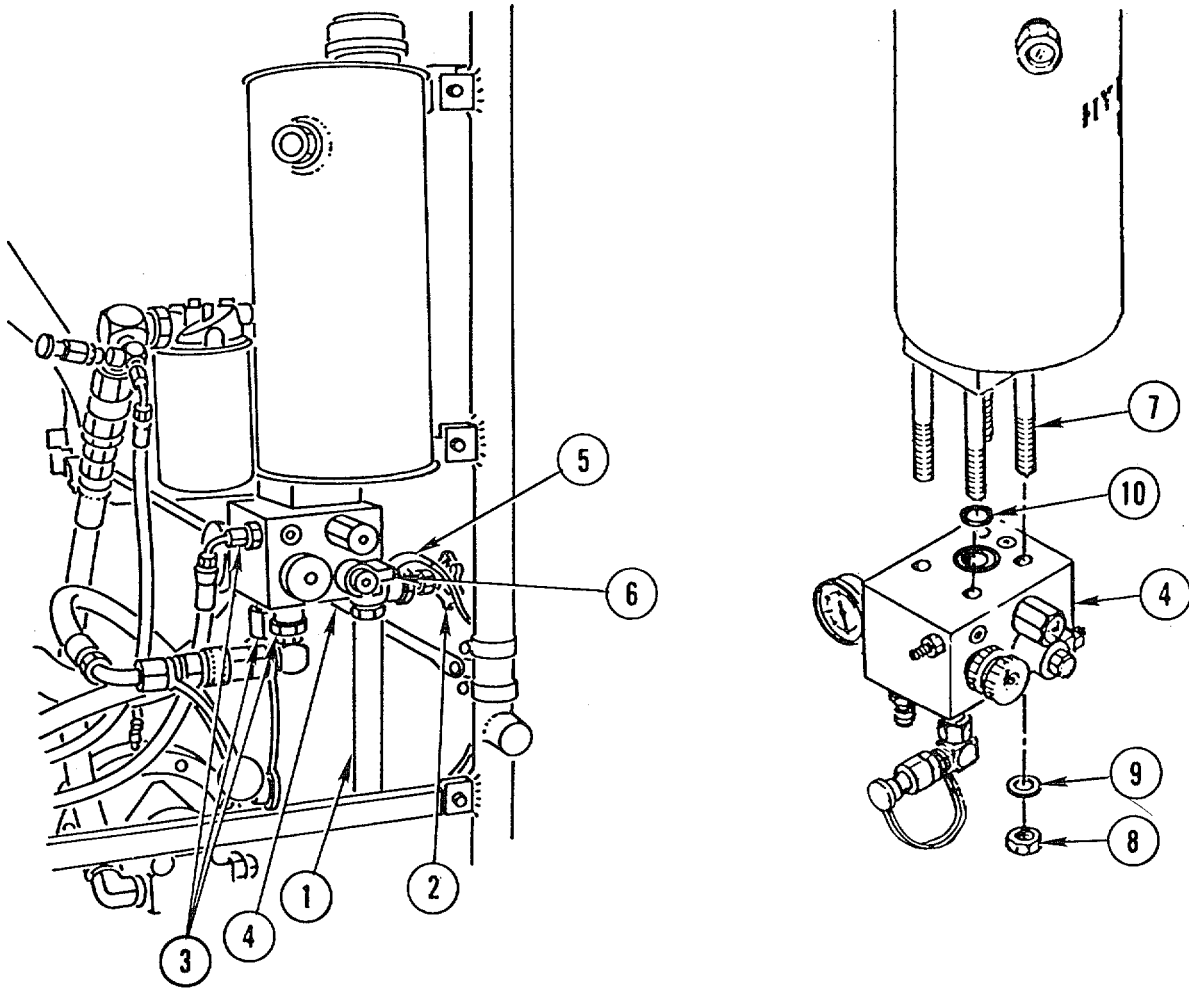

---

**PRIMARY HYDRAULIC MANIFOLD ASSEMBLY REPLACEMENT (CONT)**

---

**C. INSTALLATION**

- (1) Install new O-ring (1).
- (2) Align primary hydraulic manifold (2) with hydraulic tank mounting studs (3) and secure in place with four washers (4) and four nuts (5).
- (3) Connect two electrical leads (6) to primary hydraulic manifold 12 V coil (7).
- (4) Remove caps from lines and fittings and connect three hydraulic hoses (8) to primary hydraulic manifold (2) fittings.
- (5) Make sure gate valve (9) is closed. Fill hydraulic reservoir with hydraulic fluid (item 10, Appendix E).

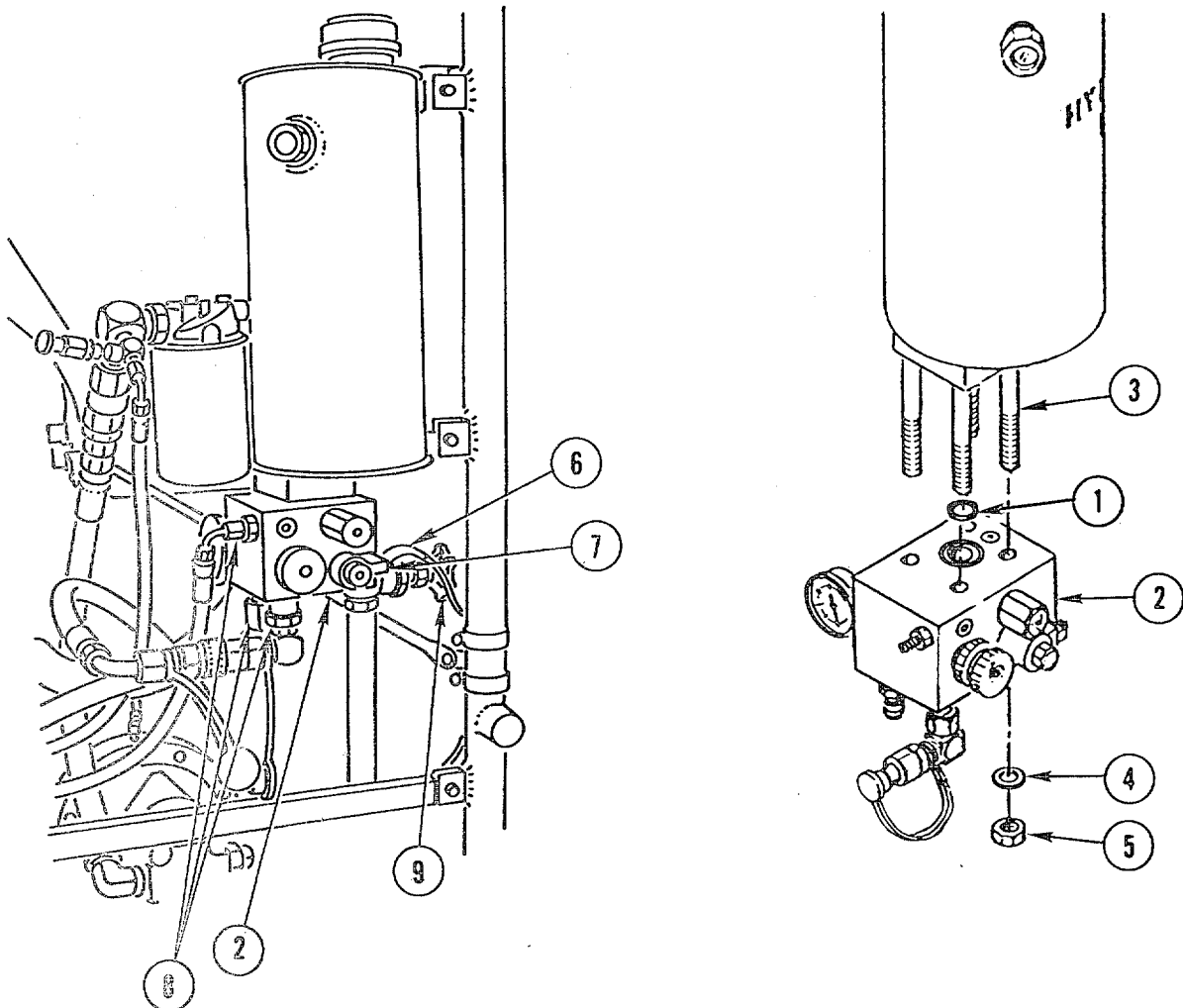

---

**4-37. BUCKET HARNESS REPLACEMENT**

---

This task covers:   Removal           Installation

**A. INITIAL SETUP**

**Tools and Special Equipment:**

Tool Kit, 5180-00-177-7033

**Equipment Condition:**

<b>Reference</b>	<b>Condition Description</b>
Paragraph 4-38	Hand Control Assembly
	Removed

---

**BUCKET HARNESS REPLACEMENT (CONT)**

---

**B. REMOVAL****NOTE**

Bucket harness electrical leads are labeled so they can be identified at time of installation.

- (1) Disconnect empty sensor 3-pole connector (1) and ground connection (2).
- (2) Disconnect female connector (3) from primary manifold.
- (3) Disconnect female connector (4) from secondary manifold.
- (4) Disconnect connectors A2 (5) leading to CDI spark plug.
- (5) Disconnect connectors A1 (6) leading to key Switchbox (black and red wire).
- (6) Disconnect connectors B1 (7) leading to rectifier assembly (white wire).
- (7) Disconnect connectors B2 (8) leading to key Switchbox (white wire).
- (8) Disconnect female piggyback disconnect (9) from starter.
- (9) Disconnect connectors J1 (10) leading to oil level switch.
- (10) Disconnect connectors J2 (11) leading to rectifier assembly.
- (11) Remove ground on housing (12).
- (12) Remove three clamps (13) and four cable ties (14) from bucket leg weldment.
- (13) Remove four cushion clamps (15) from tail fin bracket and under bucket lid lip by removing four nuts (16), eight washers (17), and four screws (18).





---

**BUCKET HARNESS REPLACEMENT (CONT)**

---

**C. INSTALLATION**

- (1) Connect ground on housing (1).
- (2) Connect rectifier assembly connectors J2 (2).
- (3) Connect oil level switch connectors J1 (3).
- (4) Connect female piggyback disconnect (4) to starter.
- (5) Connect key Switchbox (white wire) connectors B2 (5).
- (6) Connect rectifier assembly (white wire) connectors B1 (6).
- (7) Connect key Switchbox (black and red wire) connectors A1 (7).
- (8) Connect CDI ignition coil connectors A2 (8) leading to CDI spark plug.
- (9) Connect female connector (9) to secondary manifold.
- (10) Connect female connector (10) to primary manifold.
- (11) Connect empty sensor 3-pole connector (11) and ground connection (12).
- (12) Align bucket harness on bucket weldment and secure with four cable ties (13) and three clamps (14).
- (13) Route bucket harness under bucket lip until tail fin is reached.
- (14) Align four cushion clamps (15) on tail fin bracket and under bucket lid lip and secure with four screws (16), eight washers (17), and four nuts (18).

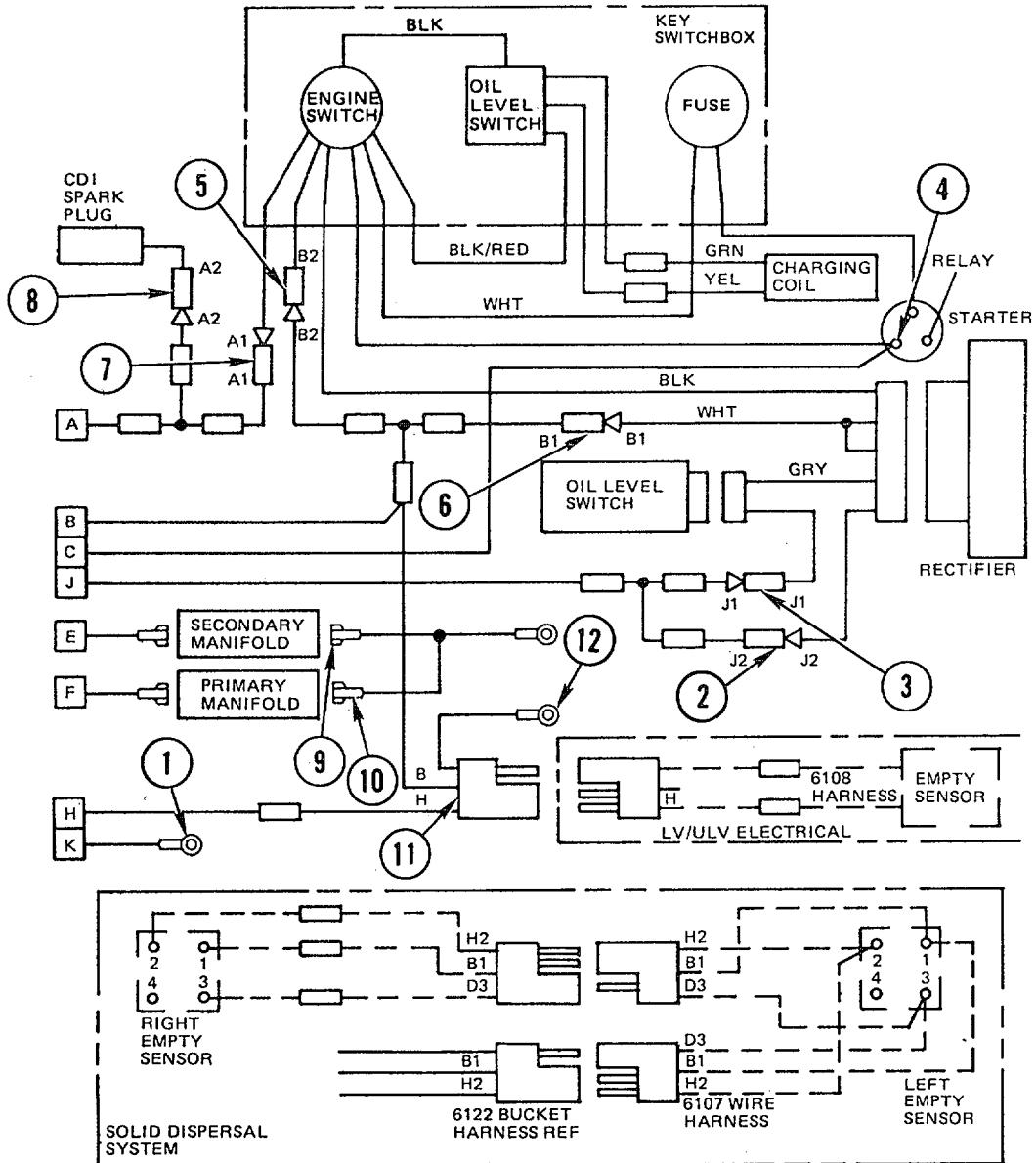

- LEGEND**
- PUSH/PULL CONNECTOR
  - 3 WAY CONNECTOR 'Y'
  - SLIDE CONNECTION
  - SPLICE CONNECTION
  - RING CONNECTOR  
GROUND ON PUMP HOUSING (STUD 5/16)

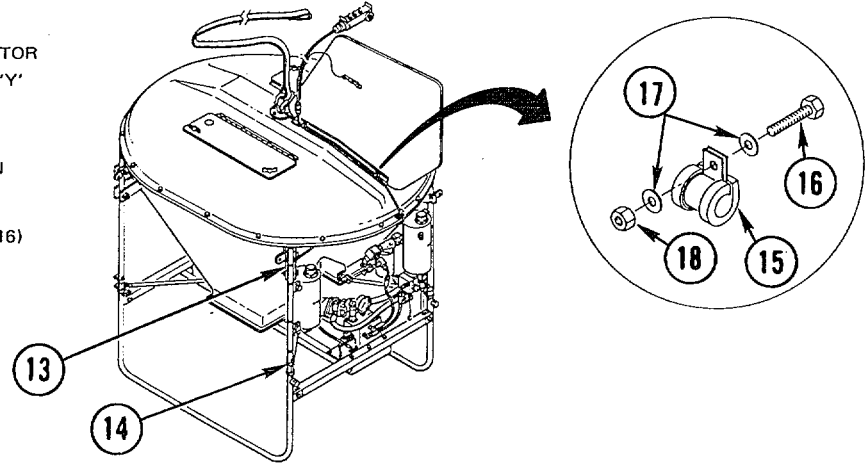

**4-38. HAND CONTROL ASSEMBLY/ELECTRICAL-SAFETY CABLE ASSEMBLY  
REPLACEMENT**

---

This task covers:    Removal            Installation

---

**A. INITIAL SETUP****Tools and Special Equipment:**

Tool Kit, 5180-00-177-7033

**Materials/Parts:**

Tie, Cable

Appendix E, Item 62

---

**B. REMOVAL****NOTE**

If hand control assembly fails to operate properly or if inspection indicates replacement is necessary, perform the following steps.

- (1) Disconnect electrical-safety cable assembly (1) from bucket harness connector (2) by pulling electrical-safety cable assembly quick-disconnect connector (3).
- (2) Disconnect electrical-safety cable assembly (1) from hand control assembly (4) by turning electrical-safety cable assembly connector (5) counterclockwise.
- (3) Disconnect safety cable assembly (6) from electrical-safety cable assembly (1) by removing screw (7) and washer (8) from fork (9).
- (4) Remove and discard cable ties (10).

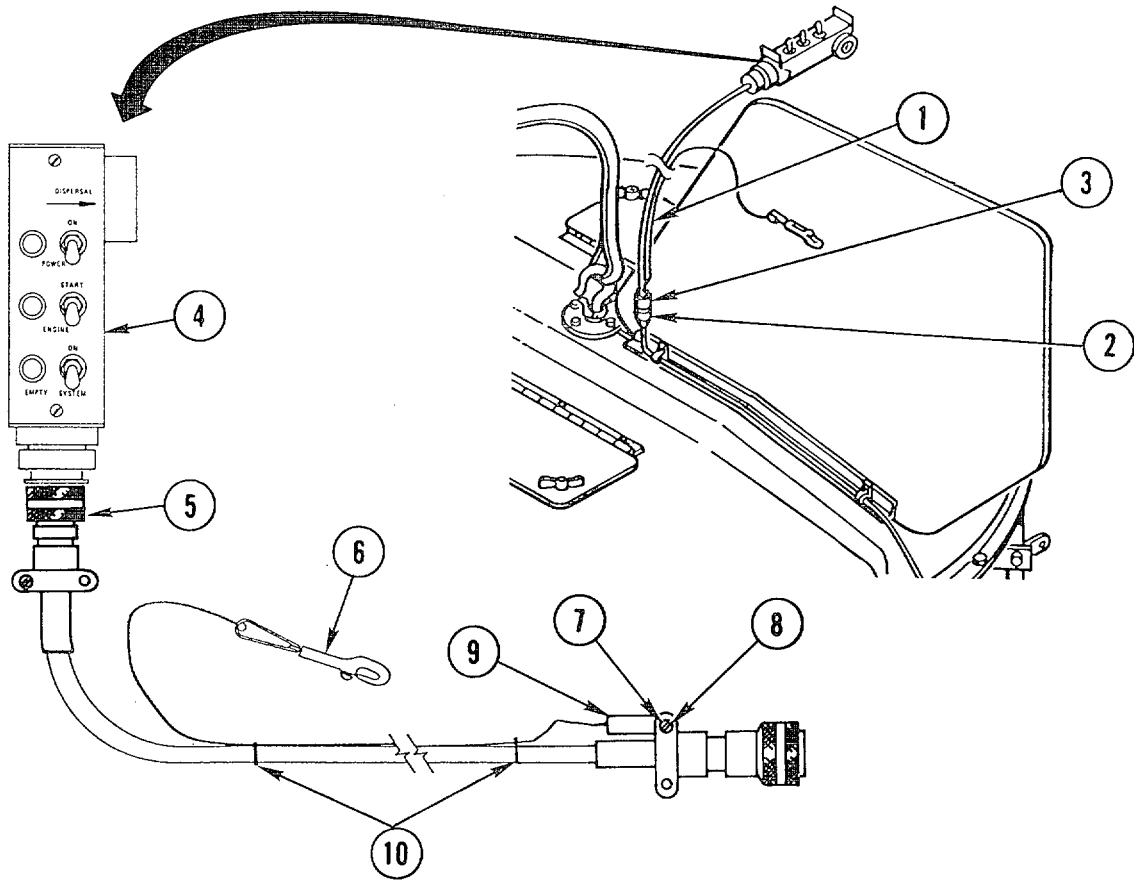

---

**HAND CONTROL ASSEMBLY/ELECTRICAL-SAFETY CABLE ASSEMBLY  
REPLACEMENT (Cont)**

---

**C. INSTALLATION**

- (1) Connect safety cable assembly (1) to electrical-safety cable assembly (2) by inserting fork (3) into slot on electrical-safety cable assembly quick-disconnect connector (4) and installing washer (5) and screw (6). Tighten securely.
- (2) Align safety cable assembly (1) with electrical-safety cable assembly (2). Remove slack and install new cable ties (7) securely around cables. Make sure safety cable assembly (1) has enough excess to securely attach to safety union without strain.
- (3) Align key in electrical-safety cable assembly connector (8) with slot in hand control assembly (9) and turn knurled area of connector (8) clockwise until assemblies are securely connected.
- (4) Align slot in electrical-safety cable assembly quick-disconnect connector (4) with key in bucket harness connector (10) and push connectors together until assemblies are securely connected.

**4-39. PUMP AND CROSSTUBE ASSEMBLY REPLACEMENT**

This task covers:    Removal            Installation

---

**A. INITIAL SETUP**

**Tools and Special Equipment:**

Tool Kit, 5180-00-177-7033

**General Safety Instructions:**

**WARNING**

Pliers, Snap Ring (Item 5, App B)  
 Make sure all liquid has been removed from bucket before removing pump and crosstube assembly from bucket. Do not allow liquid to contact skin or eyes. Wear protective clothing. Failure to do so could result in personal injury.

**Materials/Parts:**

Gasket	Appendix E, Item 11
Gasket	Appendix E, Item 12
Gasket	Appendix E, Item 13

**Personnel Required: 2**

---

**PUMP AND CROSSTUBE ASSEMBLY REPLACEMENT (CONT)**

---

**B. REMOVAL**

---

**WARNING**

---

Make sure all liquid has been removed from bucket before removing pump and crosstube assembly from bucket. Do not allow liquid to contact skin or eyes. Wear protective clothing. Failure to do so could result in personal injury.

- (1) Open ball valve (1) and gate valve (2) and drain pump and crosstube assembly into suitable container. Remove strainer (3) to drain pump. Make sure no fluid remains in dispersal system.
- (2) Disconnect two quick-disconnect hydraulic fittings (4 and 5) at secondary manifold, one quick-disconnect fitting (6) at hydraulic filter, and one quick-disconnect fitting (7) at primary manifold. Cap open lines.
- (3) Disconnect level switch wiring harness (8) from bucket harness.
- (4) Attach suitable clamp device to both crosstube weldments and remove 20 clips (9), 20 locknuts (10), 20 bolts (11), and 40 flat washers (12).
- (5) Support pump and crosstube assembly (13) and remove clamps. Using two persons, remove pump and crosstube assembly (13) from bucket.



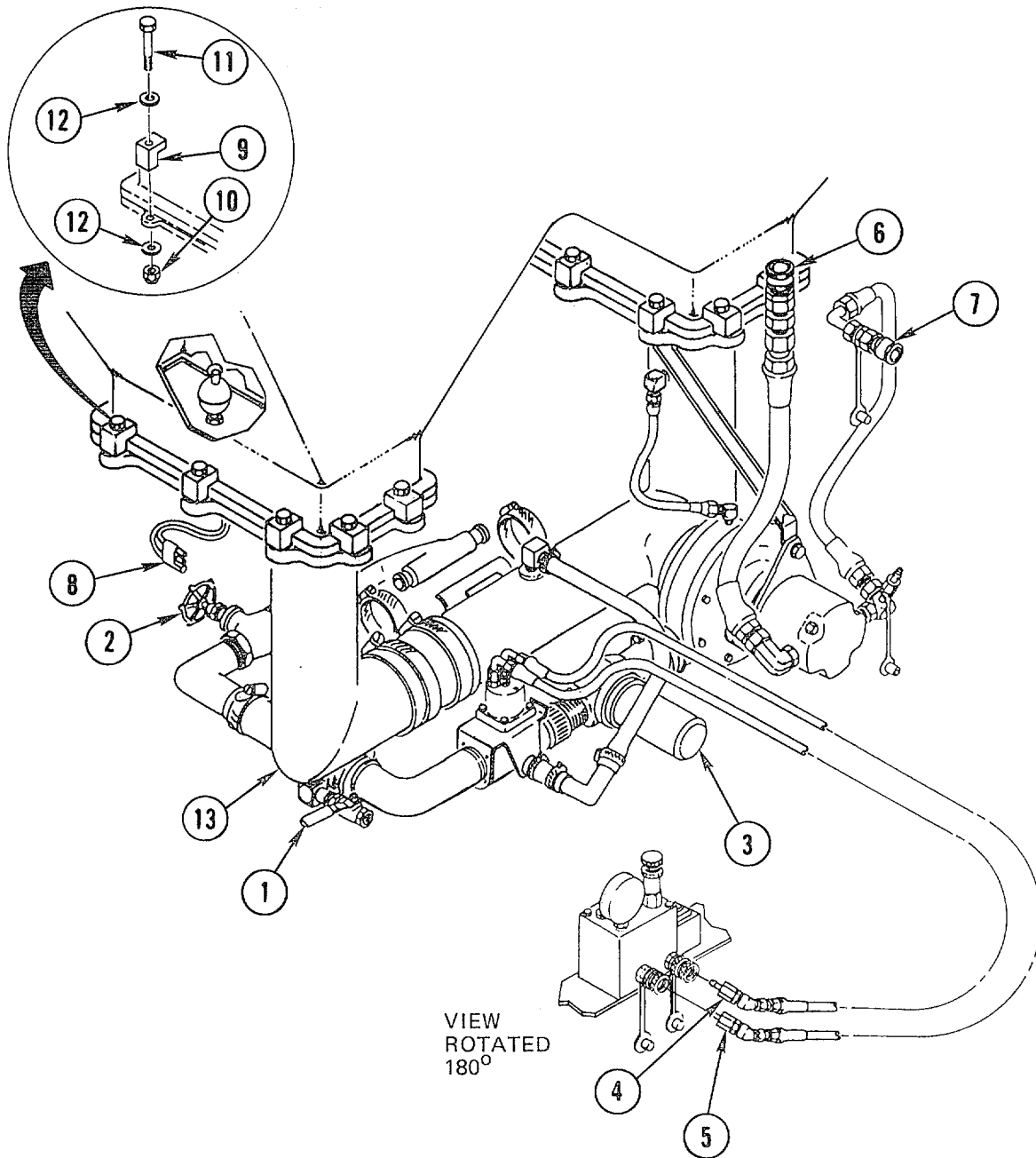

---

**PUMP AND CROSSTUBE ASSEMBLY REPLACEMENT**

---

**C. INSTALLATION**

- (1) Using two persons, support pump and crosstube assembly (1) from underneath and install pump and crosstube assembly (1) under bucket downspouts.
- (2) Loosen clamp on main crosstube weldment to allow for adjustment. Position vertical weldments under downspouts, aligning mounting holes.
- (3) Install two suitable clamps on each side of downspouts to hold weldments in position.
- (4) Adjust weldments as required to obtain tight fit and install 40 flat washers (2), 20 bolts (3), 20 locknuts (4), and 20 clips (5). Install pump strut (6) on right side downspout.
- (5) Connect level switch wiring harness (7) to bucket harness.
- (6) Connect quick-disconnect fitting (8) at primary manifold.
- (7) Connect quick-disconnect hydraulic fitting (9) to hydraulic filter.
- (8) Connect two quick-disconnect hydraulic fittings (10 and 11) from spray control assembly to rear of secondary manifold, matching marks on connectors with marks on secondary manifold.
- (9) Close ball valve (12) and gate valve (13).
- (10) Install strainer (14).

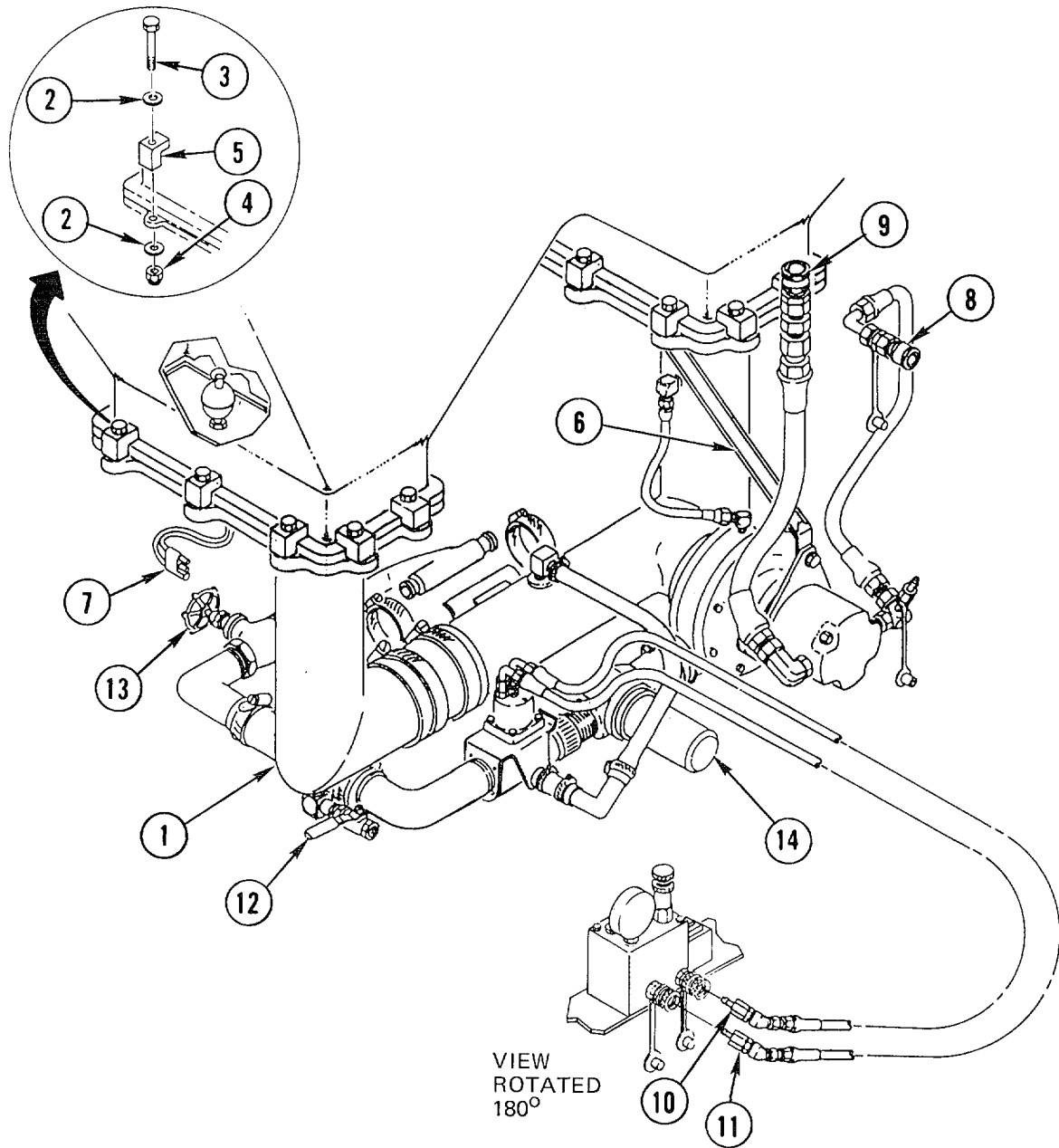

**4-40. PUMP AND CROSSTUBE ASSEMBLY LEVEL SWITCH REPLACEMENT**

---

This task covers:      Removal                      Installation

---

**A. INITIAL SETUP**

**Tools and Special Equipment:**

Tool Kit, 5180-00-177-7033

**General Safety Instructions:**

**WARNING**

**Materials/Parts:**

Tie, Cable                      Appendix E, Item 62  
 Tape, Teflon                      Appendix E, Item 61

Make sure all liquid has been removed from bucket before removing left downspout. Do not allow liquid to contact skin or eyes. Wear protective clothing. Failure to do so could result in personal injury.

**Equipment Condition:**

<b>Reference</b>	<b>Condition Description</b>
Paragraph 4-39	Bucket Drained
Paragraph 4-39	Pump and Crosstube Assembly Installed

---

**B. REMOVAL**

**WARNING**

Make sure all liquid has been removed from bucket before removing left downspout. Do not allow liquid to contact skin or eyes. Wear protective clothing. Failure to do so could result in personal injury.

- (1) Disconnect level switch 3-pole connector (1) from bucket harness connector.
- (2) Remove cable tie (2).
- (3) Cut level switch (3) wiring harness leads at both ends of splice.
- (3) Loosen one hose clamp (4) on cuff and clamp assembly (5).
- (4) Remove 10 locknuts (6), 20 flat washers (7), 10 bolts (8), and 10 clips (9) from left downspout (10). Lower left downspout (10) and remove from bucket union (11).
- (5) Loosen level switch hex shaft (12) from level switch housing in left downspout (10) and remove level switch (3) with remainder of level switch wiring harness.

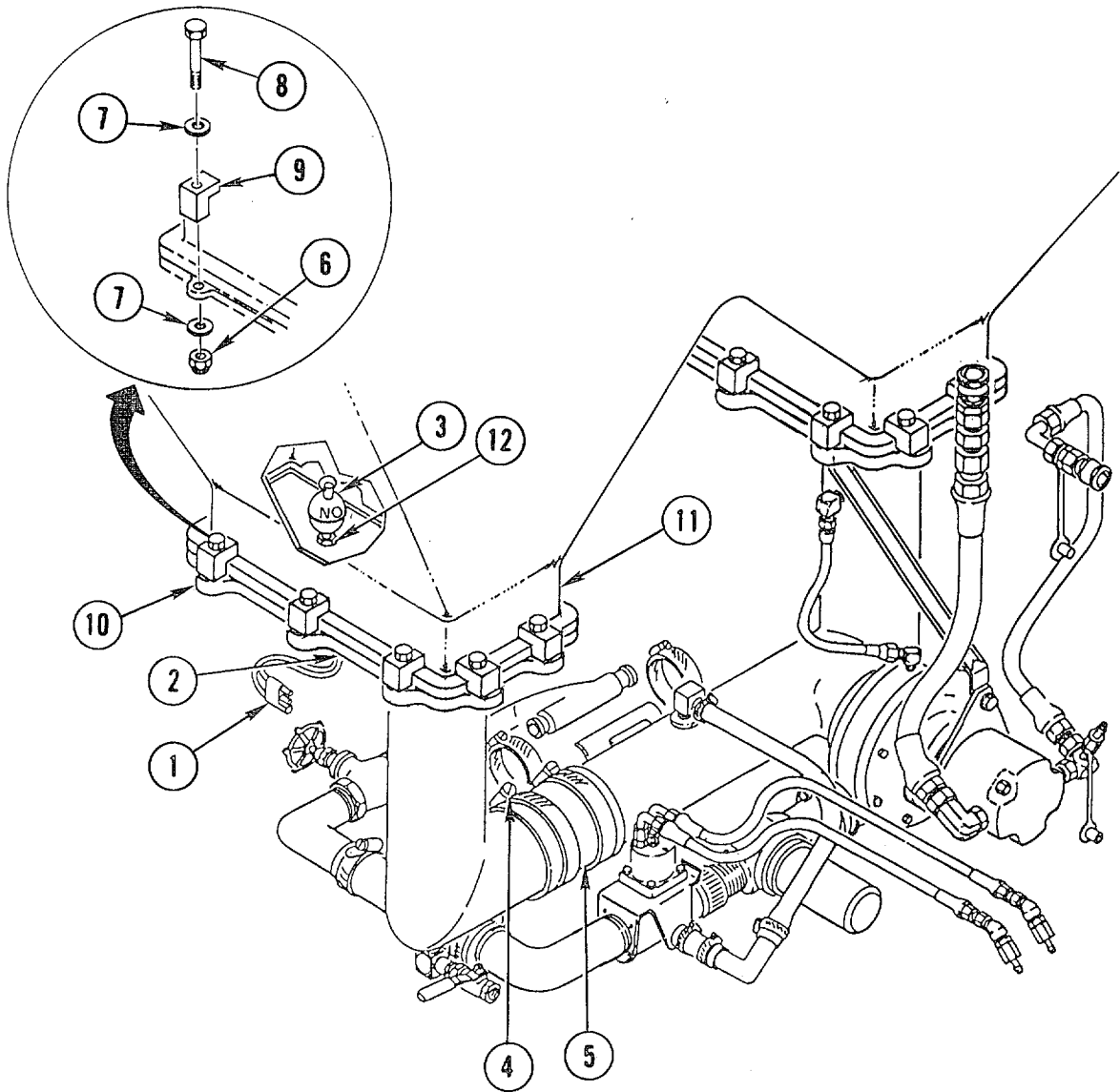

---

**PUMP AND CROSSTUBE ASSEMBLY LEVEL SWITCH REPLACEMENT (CONT)**

---

**C. INSTALLATION****CAUTION**

Make sure level switch ball is mounted with "NO" (Normally Open) on top. Failure to comply will cause hand control EMPTY light to work in reverse.

- (1) Coat threads of level switch hex shaft (1) with teflon tape (item 61, Appendix E).
- (2) Run level switch wiring harness through level switch housing in left downspout (2) until level switch (3) is in place. Tighten level switch hex shaft (1).
- (3) Splice level switch leads to level switch wiring harness wires (4).
- (4) Remove slack and secure level switch wiring harness under left downspout (2) flange using new cable tie (5).
- (5) Insert tube end of left downspout (2) securely into cuff and clamp assembly (6).
- (6) Align left downspout (2) on bucket union (7) and install 10 clips (8), 10 bolts (9), 20 flat washers (10), and 10 locknuts (11).
- (7) Tighten hose clamp (12).
- (8) Connect level switch 3-pole connector (4) to bucket harness connector.

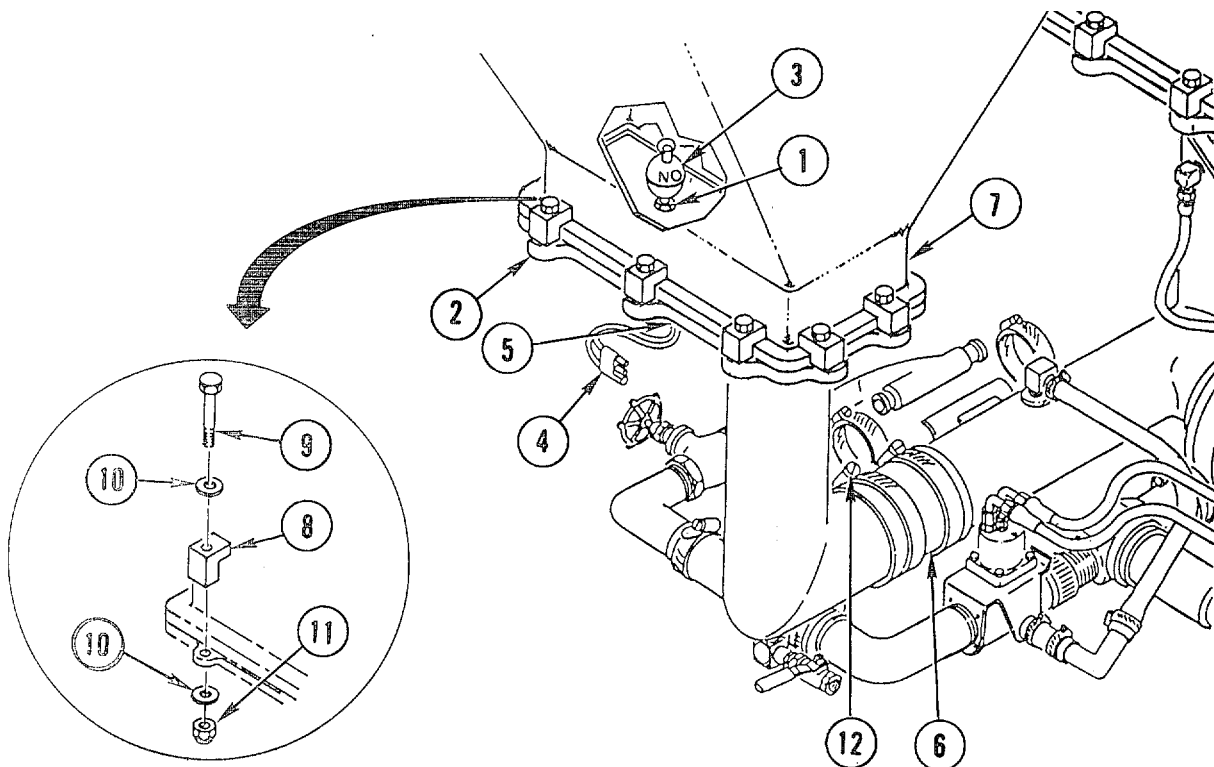

**4-41. PUMP AND CROSSTUBE ASSEMBLY REPAIR**

---

This task covers:      Disassembly      Assembly

---

**A. INITIAL SETUP**

**Tools and Special Equipment:**

Tool Kit, 5180-00-177-7033

**Equipment Condition:**

**Reference**

Paragraph 4-39

**Condition Description**

Pump and Crosstube  
Assembly Removed

**Materials/Parts:**

Gasket                      Appendix E, Item 11

Gasket                      Appendix E, Item 12

Gasket                      Appendix E, Item 13

Contact Cement,  
Barge All-Purpose              Appendix E, Item 5

---

**PUMP AND CROSSTUBE ASSEMBLE REPAIR (CONT)**

---

**B. DISASSEMBLY**

- (1) Remove hydraulic motor and chemical pump assembly (1) (para 4-42).
- (2) Remove strainer assembly (2).
- (3) Remove four clamps (3) and tygon tubing (4).
- (4) Remove spray system control assembly (5) (para 4-45).
- (5) Remove two clamps (6) and hose (7) from two 90-degree pipe elbows.
- (6) Remove gate valve (8) and ball valve (9).
- (7) Remove cuff and clamp assembly (10) from main crosstube weldment and remove two clamps (11) from main boom weldment.
- (8) Remove two dump valve gaskets (12) from top of crosstube weldments. Discard gaskets.
- (9) Remove vent hose (13) and 90-degree fitting (14) on right downspout (15).



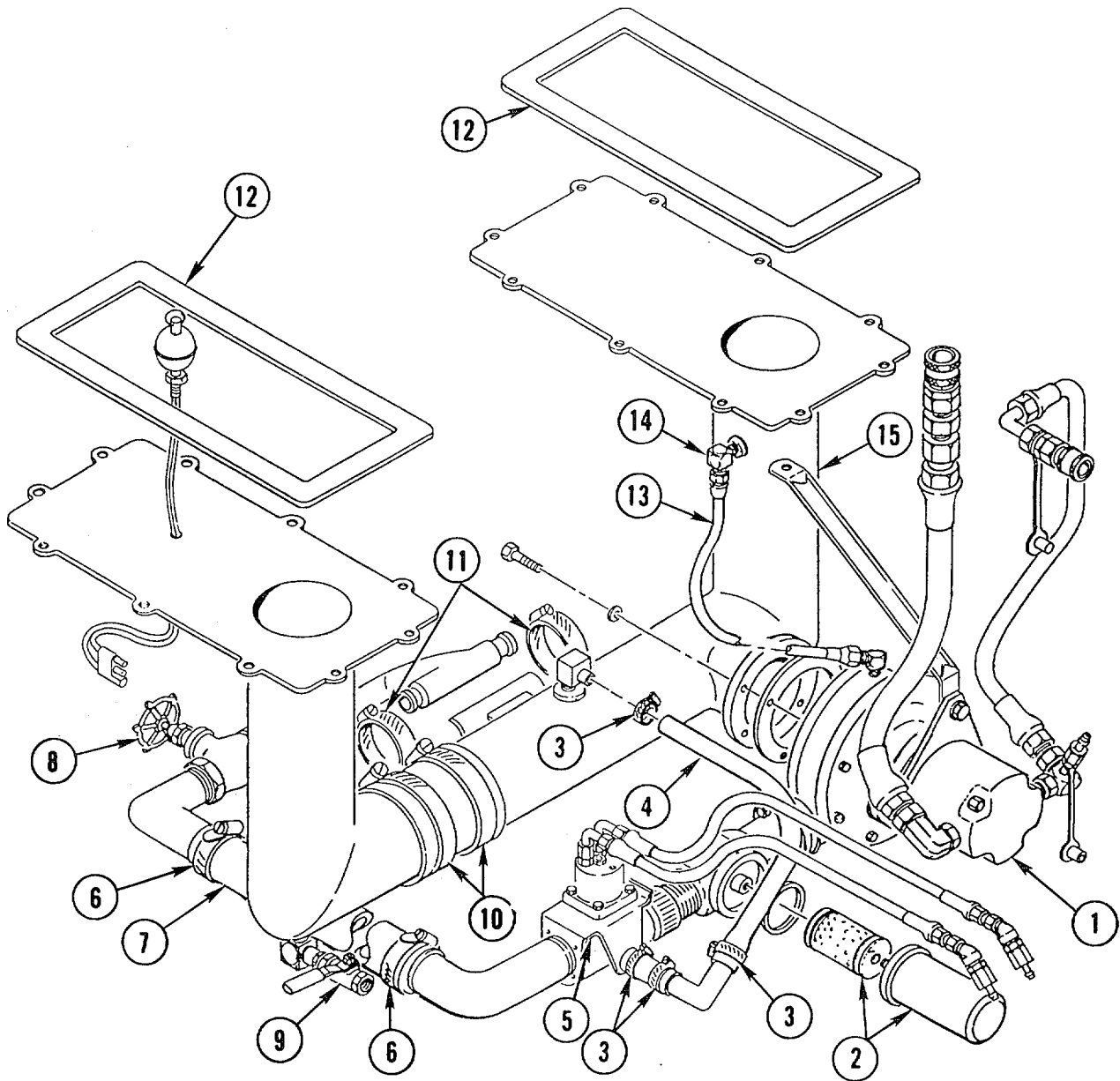

---

**PUMP AND CROSSTUBE ASSEMBLY REPAIR (CONT)**

---

**C. ASSEMBLY****NOTE**

If tygon tubing is replaced, new tubing should be cut in two lengths, 2-3/4 in. and 15 in.

- (1) Attach two new dump valve gaskets (1) on top of crosstube weldments using all-purpose contact cement (item 5, Appendix E).
- (2) Join two ends of crosstube weldment and secure together using cuff and clamp assembly (2).
- (3) Install hydraulic motor and chemical pump assembly (3) and new gaskets (para 4-42).
- (4) Install strainer assembly (4) on pump flange elbow.
- (5) Install spray system control assembly (5) (para 4-45).
- (6) Install tygon tubing (6) and four clamps (7) on 90-degree elbow.
- (7) Install tygon tubing (6) on spray system control assembly (5) and 90-degree elbow fitting. Tighten clamps (7).
- (8) Install center boom weldment in main crosstube weldment bracket. Secure using two clamps (8).
- (9) Install ball valve (9) on center boom weldment. Install gate valve (10) on adapter and install adapter in 90-degree elbow fitting.
- (10) Install hose (11) and two clamps (12) on two 90-degree pipe elbows. Install one end of assembly in ball valve (9) and other end in spray system control assembly (5).
- (11) Install 90-degree fitting (13) on right downspout (14).
- (12) Install vent hose (15) on 90-degree fitting (13).

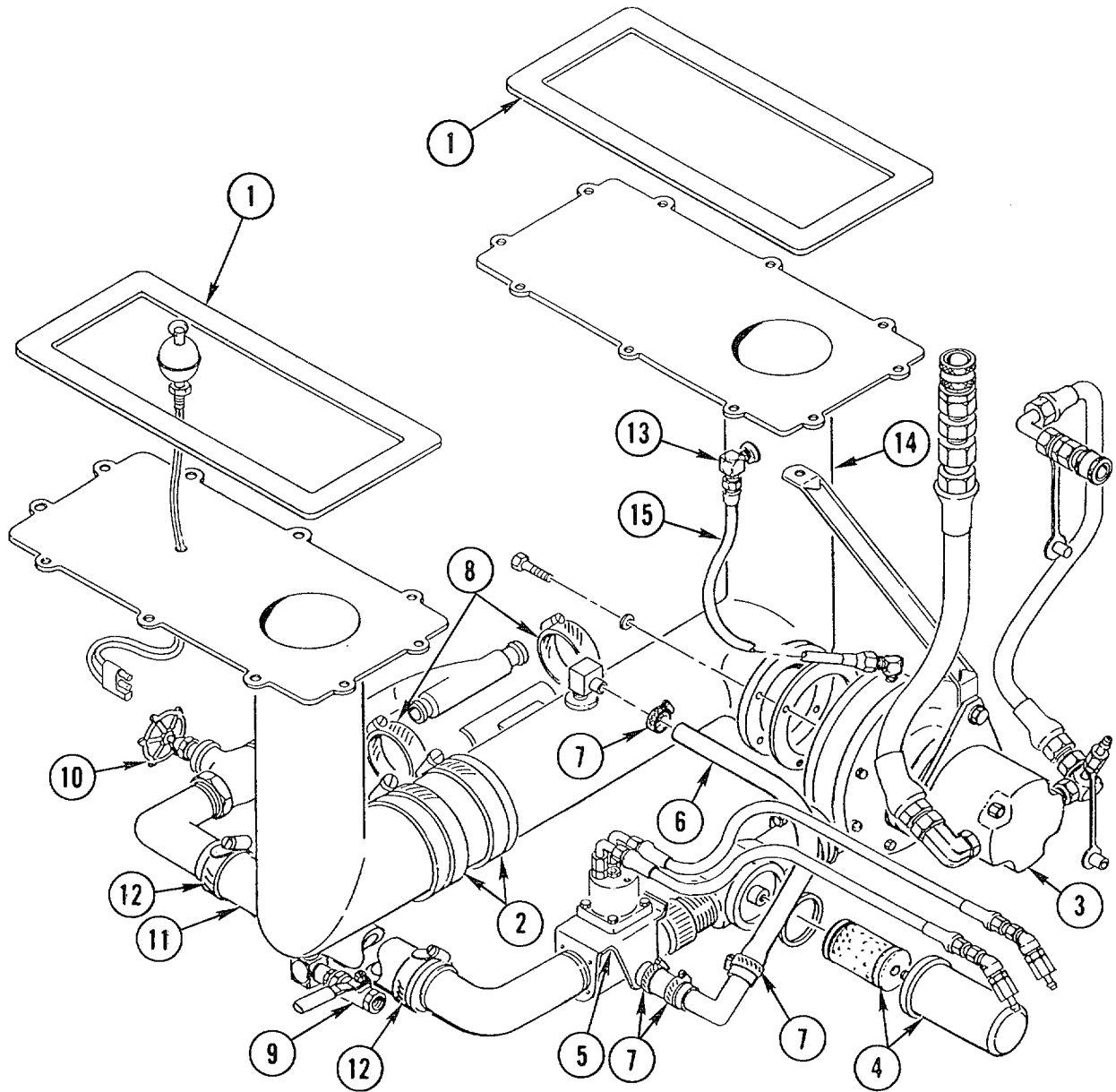

**4-42. PUMP AND CROSSTUBE ASSEMBLY HYDRAULIC MOTOR AND CHEMICAL PUMP ASSEMBLY REPLACEMENT**

---

This task covers:      Removal                      Installation

---

**A. INITIAL SETUP**

**Tools and Special Equipment:**

Tool Kit, 5180-00-177-7033

**Materials/Parts:**

Gasket	Appendix E, Item 12
Gasket	Appendix E, Item 13

---

**B. REMOVAL**

- (1) Disconnect vent hose (1) from fitting (2).
- (2) Disconnect hydraulic lines (3 and 4) from motor (5). Cap open lines.
- (3) Remove four bolts (6), four washers (7), gasket (8), and flange adapter (9) from pump flange. Discard gasket.
- (4) Remove four bolts (10) and four washers (11) attaching hydraulic motor and chemical pump assembly (5) to intake elbow (12). Remove hydraulic motor and chemical pump assembly (5) and gasket (13) from crosstube assembly. Discard gasket.

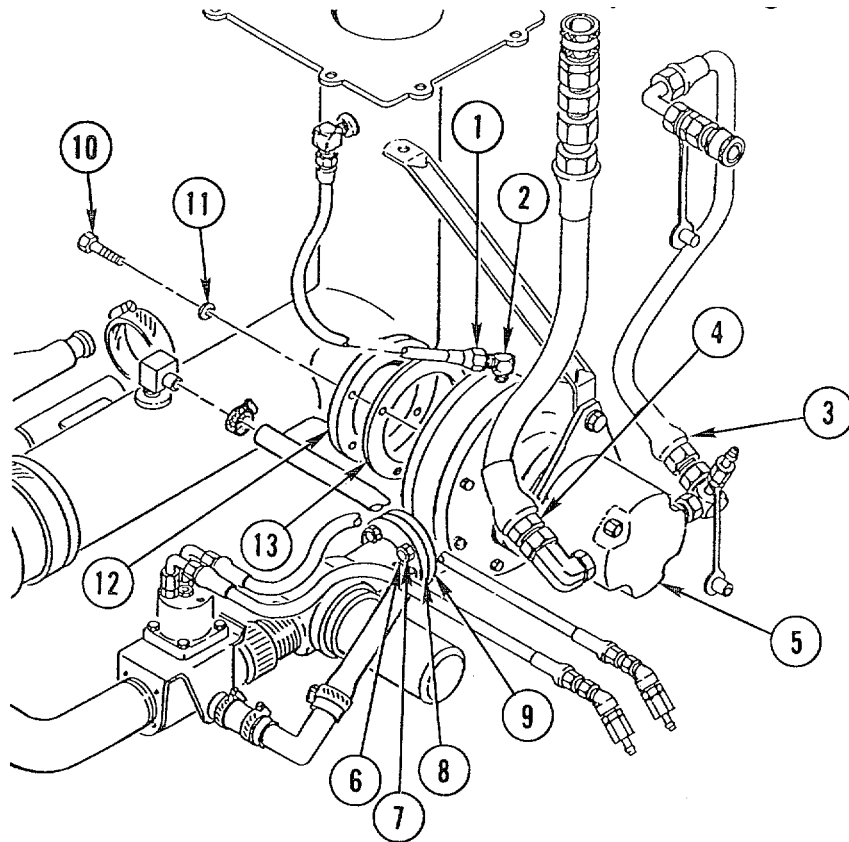

**C. INSTALLATION**

- (1) Align new gasket (1) and hydraulic motor and chemical pump assembly (2) on intake elbow (3) and secure with four washers (4) and four bolts (5).
- (2) Install flange adapter (6) and new gasket (7) on pump flange and secure with four washers (8) and four bolts (9).
- (3) Remove caps and connect hydraulic lines (10 and 11) to motor (2).
- (4) Point fitting (12) toward main crosstube weldment.
- (5) Connect vent hose (13) to fitting (12).

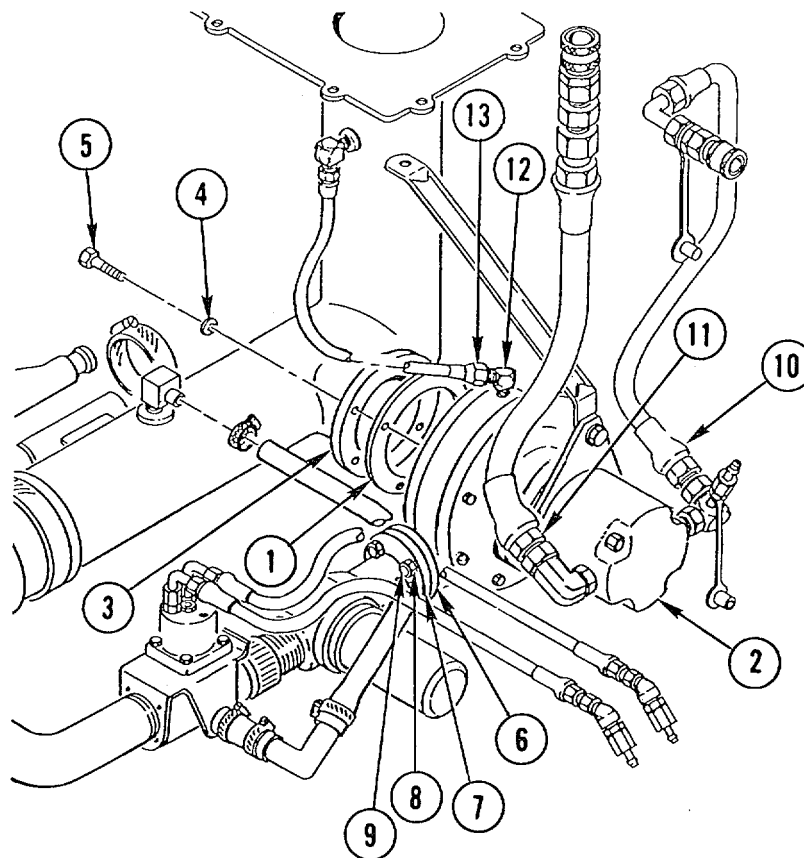

**4-43. PUMP AND CROSSTUBE ASSEMBLY CHEMICAL PUMP REPLACEMENT**

This task covers:      Disassembly      Assembly

**A. INITIAL SETUP**

**Tools and Special Equipment**

Tool Kit, 5180-00-177-7033

**Equipment Condition:**

**Reference**

Paragraph 4-42

**Condition Description**

Hydraulic Motor and  
Chemical Pump  
Assembly Removed

**B. DISASSEMBLY**

- (1) Remove two nuts (1), two washers (2), and two bolts (3) that secure motor (4) to pump (5) flange.
- (2) Remove pump mounting brace (6). Pump strut (7) may remain attached to pump mounting brace (6).
- (3) Separate motor (4) from pump (5).

**CAUTION**

Keep work area as clean as possible to prevent contamination of pump internal parts. Dirt or grit will damage machined surfaces, resulting in leaks or premature pump failure.

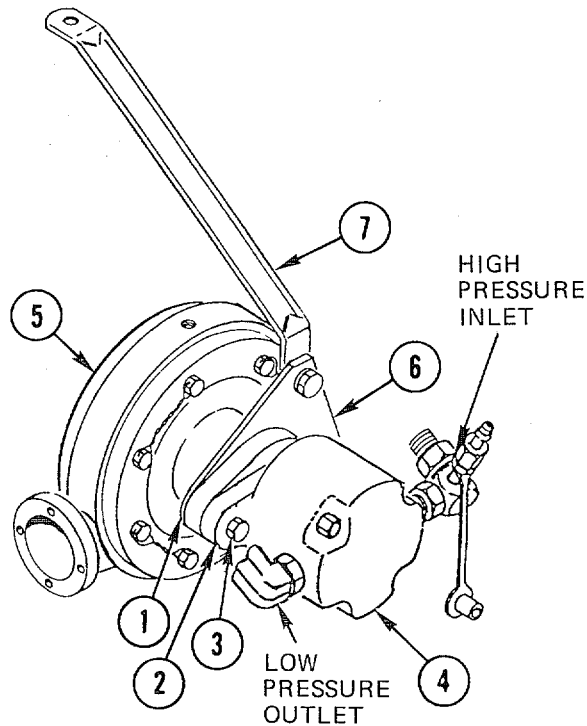

**C. ASSEMBLY****NOTE**

When assembling pump and motor, low-pressure outlet must be on same side as pump outlet.

- (1) Align key on motor shaft with keyway of new pump.
- (2) Slide shaft of motor (1) into new pump (2).
- (3) Install two bolts (3) through bolt holes on motor (1) and pump (2).
- (4) Install pump mounting brace (4) over ends of two bolts (3).
- (5) Install two washers (5) and secure with two nuts (6).

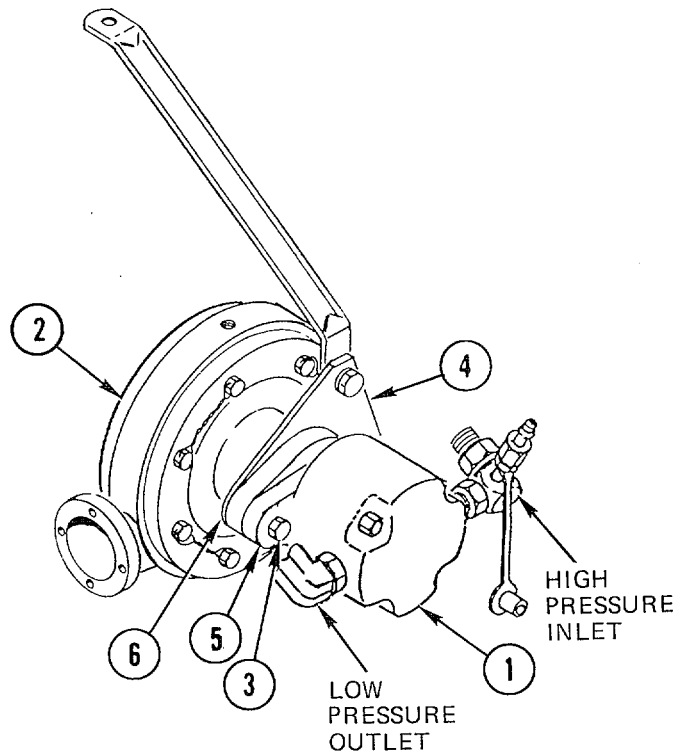

**4-44. PUMP AND CROSSTUBE ASSEMBLY HYDRAULIC MOTOR REPLACEMENT**

This task covers: Testing

**A. INITIAL SETUP**

**Tools and Special Equipment**

Tool Kit, 5180-00-177-7033

**Equipment Condition:**

**Reference**

Paragraph 4-42

**Condition Description**

Hydraulic Motor and  
Chemical Pump  
Assembly Removed

**B. DISASSEMBLY**

**CAUTION**

Keep work area as clean as possible to prevent contamination of pump internal parts. Dirt or grit will damage machined surfaces, resulting in leaks or premature pump failure.

- (1) Remove two nuts (1), two washers (2), and two bolts (3) that secure motor (4) to pump flange (5).
- (2) Remove pump mounting brace (6). Pump strut (7) may remain attached to pump mounting brace (6).
- (3) Separate motor (4) from pump (5).

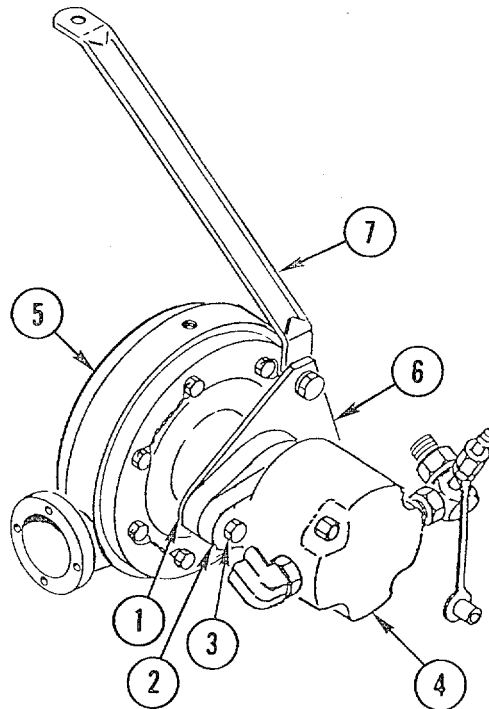



**C. ASSEMBLY****NOTE**

When assembling pump and motor, low-pressure outlet must be on same side as pump outlet.

- (1) Align key on motor shaft with keyway of new pump.
- (2) Slide shaft of new motor (1) into pump (2).
- (3) Install two bolts (3) through bolt holes on motor (1) and pump (2).
- (4) Install pump mounting brace (4) over ends of two bolts (3).
- (5) Install two washers (5) and secure with two nuts (6).

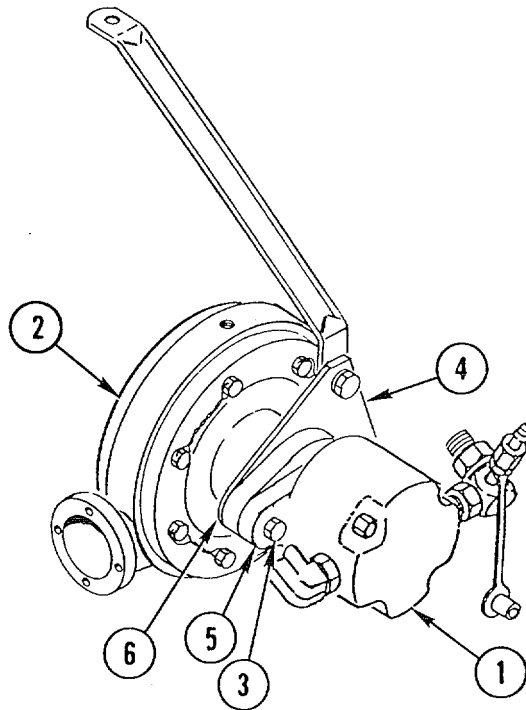

**4-45. PUMP AND CROSSTUBE ASSEMBLY SPRAY SYSTEM CONTROL REPLACEMENT**

---

 This task covers:      Removal                      Installation
 

---

**A. INITIAL SETUP****Tools and Special Equipment:**

Tool Kit, 5180-00-177-7033

**Materials/Parts:**

Tape, Teflon

Appendix E, Item 61

**B. REMOVAL**

- (1) Disconnect hydraulic lines from fittings (1 and 2) on top of miniactuator (3). Cap open lines.
- (2) Loosen clamp (4) and remove tubing (5) from recirculation suck-back (6).
- (3) Loosen assembly nut (7) that secures spray system control assembly (8) to nipple on strainer housing (9) and pull spray system control assembly (8) away from strainer housing (9).
- (4) Unscrew and remove spray system control assembly (8) from 90-degree elbow pipe (10). Remove spray system control assembly (8) from pump and crosstube.
- (5) Remove old teflon tape from threads of 90-degree elbow pipe (10).

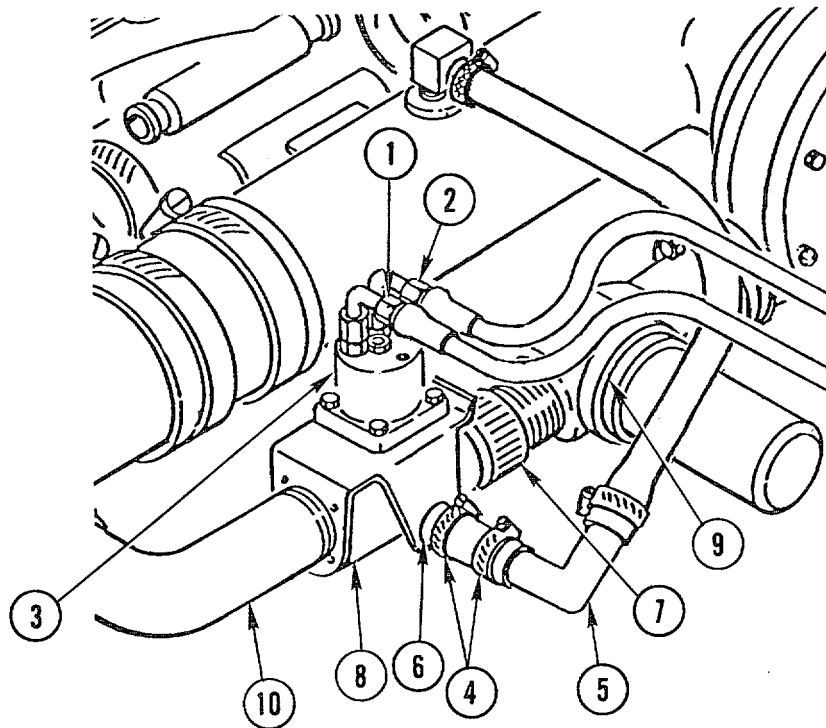

**C. INSTALLATION**

- (1) Wrap threads of 90-degree elbow pipe (1) with new teflon tape (item 61, Appendix E).
- (2) Thread 90-degree elbow pipe (1) on spray system control assembly (2).
- (3) Install spray system control assembly (2) securely on nipple at strainer housing (3). Hand-tighten assembly nut (4).
- (4) Install tubing (5) on recirculation suck-back (6). Tighten clamp (7).
- (5) Remove caps and install hydraulic lines on fittings (8 and 9) on top of miniactuator (10).

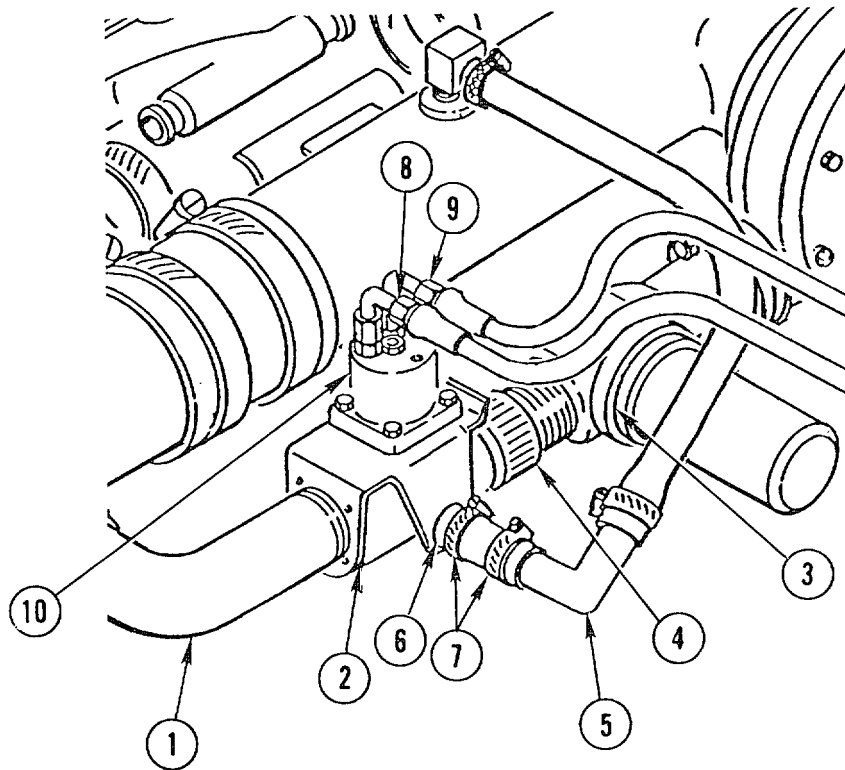

**4-46. LV BOOM ASSEMBLY REPLACEMENT/REPAIR**

---

This task covers:      Removal/Disassembly                      Assembly/Installation

---

**A. INITIAL SETUP**

**Tools and Special Equipment:**

Tool Kit, 5180-00-177-7033

**Equipment Condition:**

<b>Reference</b>	<b>Condition Description</b>
Paragraph 4-39	Pump and Crosstube Assembly Installed

**Materials/Parts:**

Pin, Quick-Release	Appendix E, Item 45
Assembly, Wire Rope	Appendix E, Item 1
Clamp, Cushion	Appendix E, Item 3

---

**LV BOOM ASSEMBLY REPLACEMENT/REPAIR (CONT)**

---

**B. REMOVAL/DISASSEMBLY****NOTE**

Repair of the LV boom is limited to replacement of damaged wire rope assemblies, cushion clamps, quick-release pins, and nozzles.

Both LV boom assemblies are removed/disassembled the same way. The following procedure is for the right-side LV boom assembly.

Booms and struts are number and color-coded; right is green and left is red. The "connect points" referred to in this procedure are the places on the boom assembly where struts and booms with like colors and numbers are to be joined.

- (1) Remove clamps (1, 2, and 3) from boom. Pull back Kamlock ears and remove boom extension (4) at Connect Point 11.
- (2) Apply upward pressure to outboard boom weldment (5) and remove quick-release pin (6) at Connect Point 7.
- (3) Pull back Kamlock ears and remove outboard boom weldment (5).
- (4) Remove two quick-release pins (7 and 8) at Connect Points 8 and 9. Remove two struts (9 and 10).
- (5) Remove quick-release pins (11 and 12) at Connect Points 5 and 6. Remove cross strut (13).
- (6) Remove quick-release pin (14) at Connect Point 4. Remove two struts (15 and 16).
- (7) Remove quick-release pin (17) at Connect Point 3.
- (8) Pull Kamlock ears back and remove outboard boom weldment (18) from center boom weldment (19) of pump and crosstube assembly.
- (9) Remove two quick-release pins (20 and 21) at Connect Points 1 and 2. Remove two struts (22 and 23).
- (10) If damaged, unscrew and remove spray nozzles (24).

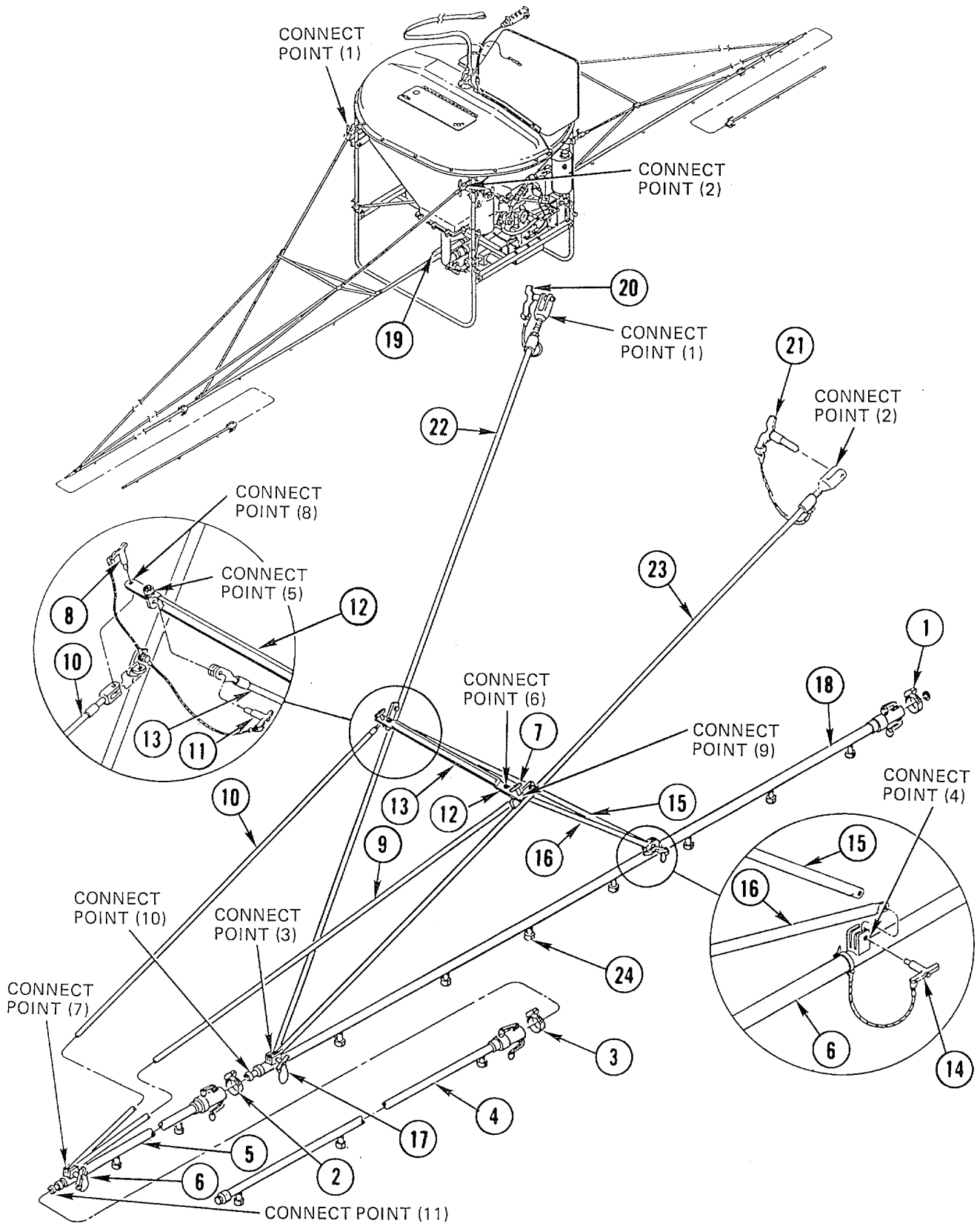

---

**LV BOOM ASSEMBLY REPLACEMENT/REPAIR (CONT)**

---

**C. ASSEMBLY/INSTALLATION**

- (1) Remove any SD system or ULV system components from bucket assembly. Cap hydraulic lines.
- (2) Lay out boom weldments, boom extension, and struts in numerical order according to numbers marked on ends.

**NOTE**

Both LV boom assemblies are assembled/installed the same way. The following procedure is for the left-side LV boom assembly.

Booms and struts are number and color-coded; right is green and left is red. The "connect points" referred to in this procedure are the places on the boom assembly where struts and booms with like colors and numbers are to be joined.

Strut tabs must point up. Nozzles must face rear of bucket. End of strut should be at a 15-degree angle to centerline of boom.

- (3) Connect Points 1 and 2: Install two struts (1 and 2) at top of right bucket leg weldments and secure to strut anchors (3 and 4) using two quick-release pins (5 and 6).
- (4) Install boom weldment (7) on center boom weldment (8) of pump and crosstube assembly and secure by closing Kamlock ears over end of boom weldment. Do not install clamp (9) at this time.
- (5) Connect Point 3: Using upward pressure, connect other ends of struts (1 and 2) to boom weldment (7) at Connect Point 3 using quick-release pin (10).
- (6) Connect Point 4: Attach struts (11 and 12) to boom weldment (7) at Connect Point 4 using quick-release pin (13).
- (7) Connect Points 5 and 6: Attach opposite ends of struts (11 and 12) to eyebolts on cross strut (14) at Connect Points 5 and 6 using quick-release pins (15 and 16). Do not tighten eyebolts at this time.
- (8) Connect Point 10: Install outboard boom weldment (17) on boom weldment (7). Secure by closing Kamlock ears over connection. Do not install clamp (18) at this time.
- (9) Connect Point 7: Attach struts (19 and 20) to outboard boom weldment (17) at Connect Point 7 using quick-release pin (21).
- (10) Connect Points 8 and 9: While supporting end of weldment (17), connect cross strut (14) to struts (1, 2, 19, and 20) at Connect Points 8 and 9 using quick-release pins (22 and 23).
- (11) Connect Point 11: Install boom extension (24) on end of outboard boom weldment (17) and secure by closing Kamlock ears over connection.
- (12) Install clamps (9, 18, and 25) over Kamlock ears and through rings on booms and tighten.
- (13) If removed, install spray nozzles (26) on booms.

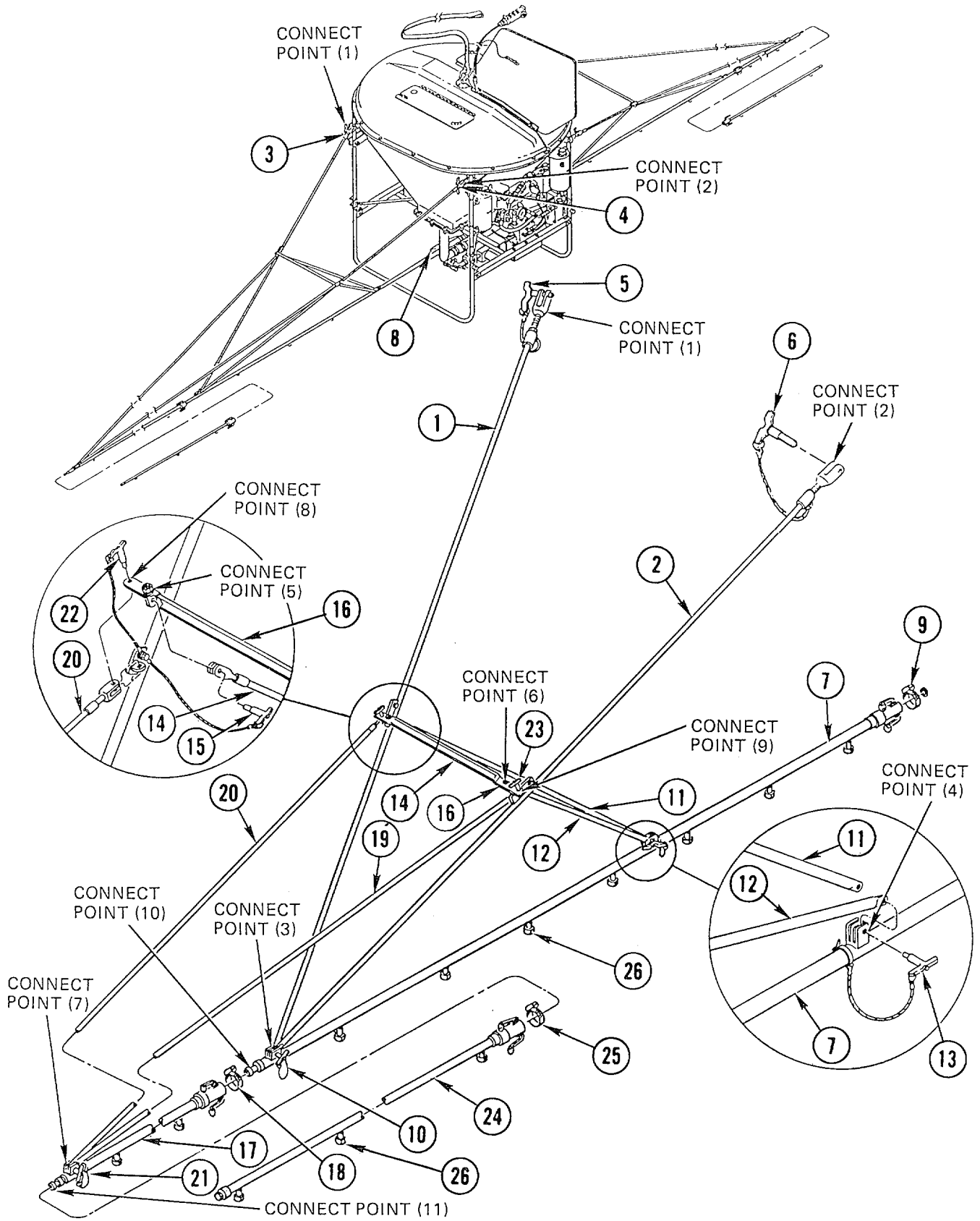





**C. ASSEMBLY/INSTALLATION**

- (1) Install relief diaphragm (7) in retainer (6).
- (2) Install retainer (6) on body (8).
- (3) Install spraying disc (4) and core seal (5) in quickjet cap (3). Install quickjet cap on body (8).

**CAUTION**

Nozzles are plastic and booms are aluminum. Be careful not to crosstread or damage spray nozzles during installation.

- (4) Screw spray nozzle (1) into boom (2).

**4-48. ULV BOOM ASSEMBLY REPLACEMENT**

---

This task covers:      Removal                      Installation

---

**A. INITIAL SETUP**

**Tools and Special Equipment**

Tool Kit, 5180-00-177-7033:

**General Safety Instructions:**

**WARNING**

**Equipment Condition:**

Make sure all liquid has been removed from pump and crosstube assembly or booms. Failure to do so could result in personal injury.

<b>Reference</b>	<b>Condition Description</b>
Paragraph 4-39	Pump and Crosstube Assembly Installed

---

**B. REMOVAL**

**WARNING**

Make sure all liquid has been removed from pump and crosstube assembly or booms. Failure to do so could result in personal injury.

- (1) Open ball valve (1) and gate valve (2) on pump and crosstube assembly and drain any liquid into suitable container.
- (2) Disconnect hydraulic quick-disconnect fitting (3) from hydraulic filter elbow fitting.
- (3) Disconnect hydraulic quick-disconnect fitting (4) from hydraulic pump.
- (4) Remove clamps (5) from Kamlock ears on center boom.
- (5) Disconnect Kamlock hose ends (6 and 7) from center boom (8) by opening Kamlock ears.
- (6) Remove ULV boom (9) from ULV attachment points on bucket assembly by removing two quick-release pins (10 and 11).

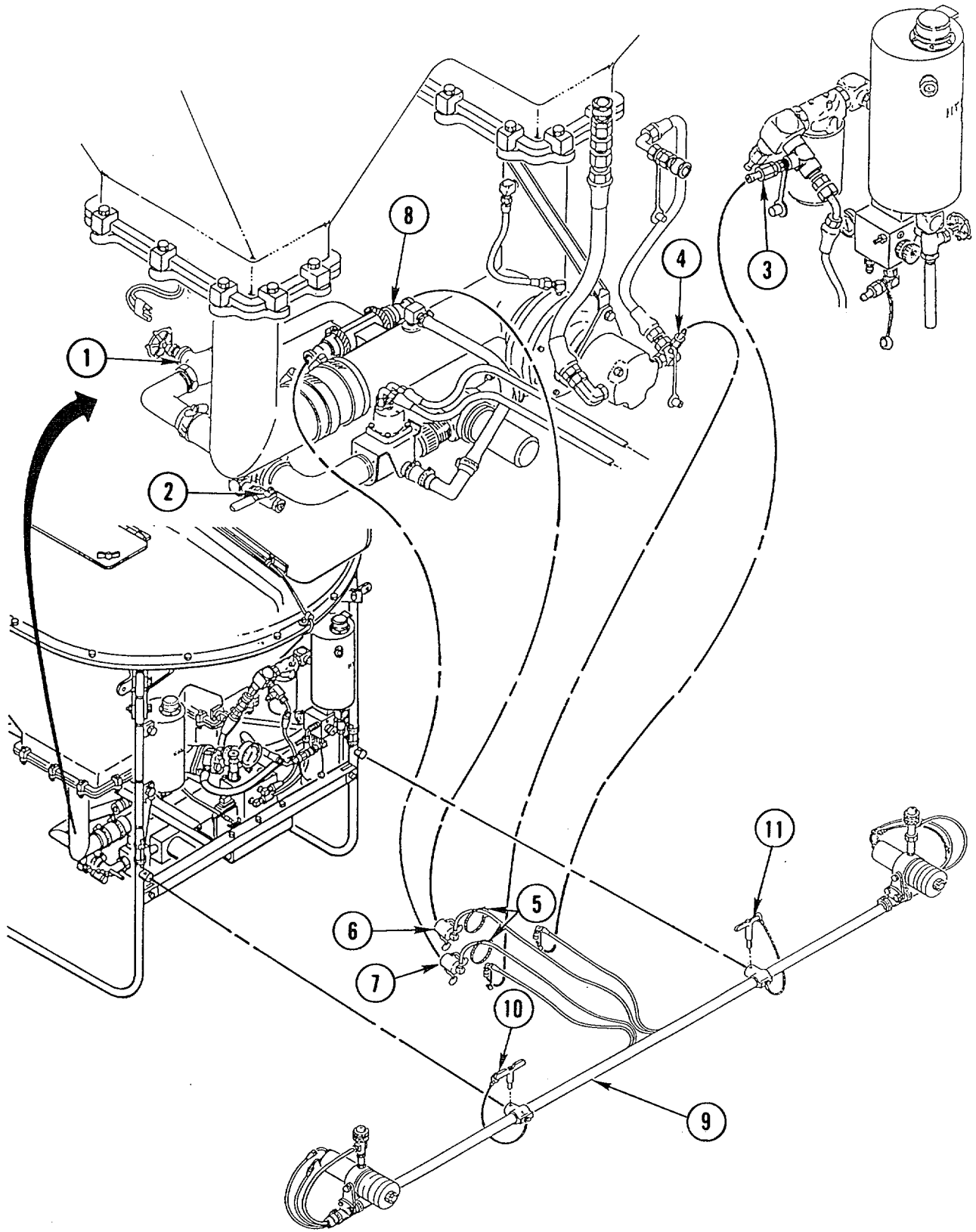

---

**ULV BOOM ASSEMBLY REPLACEMENT (CONT)**

---

**C. INSTALLATION**

- (1) Remove any SD system or LV system components from bucket assembly.
- (2) Attach ULV boom (1) to ULV attachment points on bucket assembly using two quick-release pins (2 and 3).
- (3) Attach Kamlock hose ends (4 and 5) over crosstube to center boom (6). Secure by closing Kamlock ears (7).
- (4) Install clamps (8) over Kamlock ears and tighten.
- (5) Attach hydraulic quick-disconnect fitting (9) to hydraulic pump.
- (6) Attach hydraulic quick-disconnect fitting (10) to hydraulic filter elbow fitting.
- (7) Make sure crosstube ball valve (11) is completely closed and gate valve (12) is open.

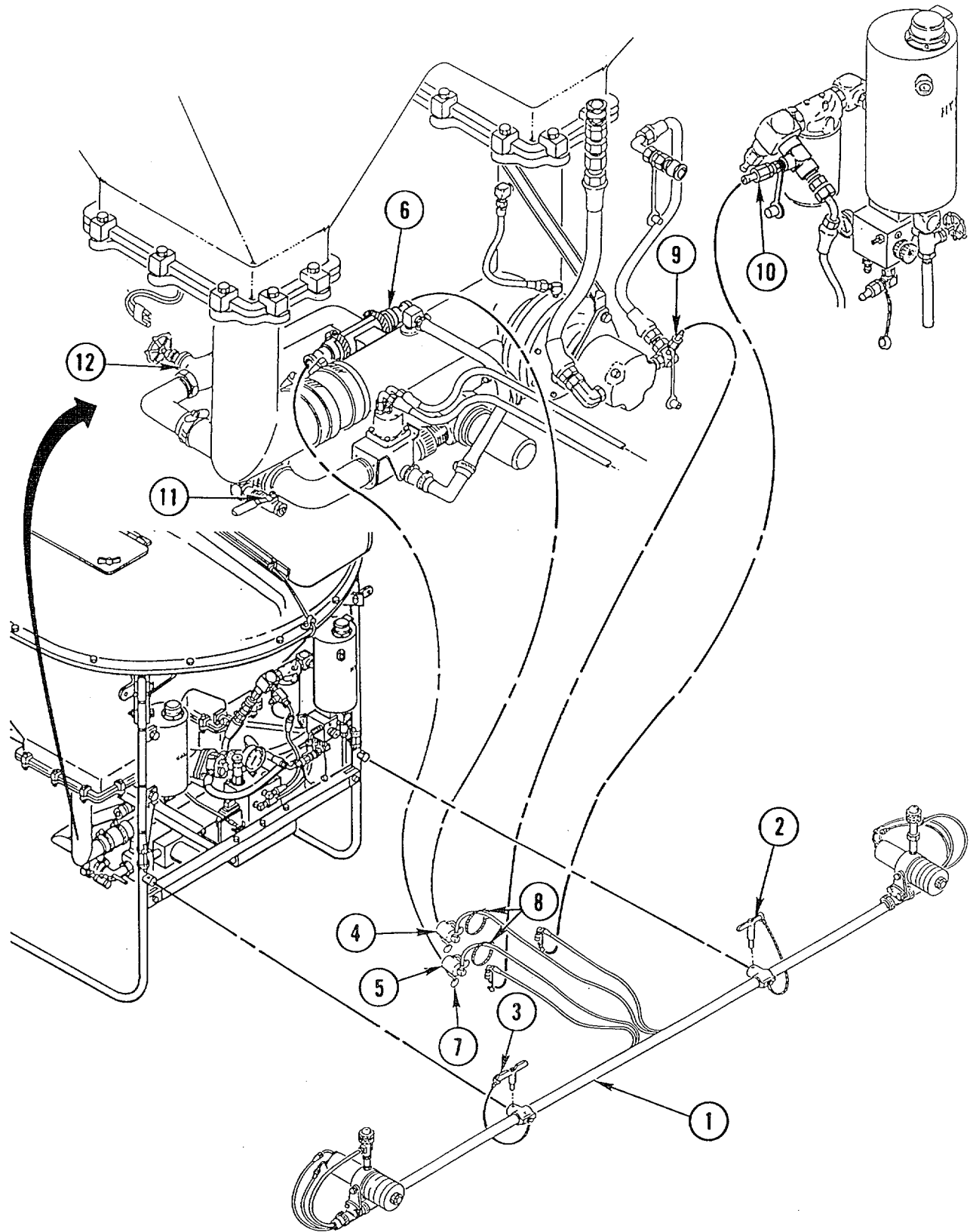

**4-49. ULV BOOM ASSEMBLY REPAIR**

---

This task covers:      Disassembly                      Assembly

---

**A. INITIAL SETUP**

**Tools and Special Equipment:**

Tool Kit, 5180-00-177-7033

**Equipment Condition:**

Reference	Condition Description
Paragraph 4-48	ULV Boom Assembly Removed

---

**B. DISASSEMBLY**

- (1) Disconnect hydraulic hoses (1 and 2) from two rotary atomizer assemblies (3).
- (2) Disconnect two push-on hoses (4) from two tee-jet diaphragms (5).
- (3) Remove two fittings (6) from two push-on hoses (4).
- (4) Remove two cap assemblies (7) and two clamps (8) from two push-on hoses (4).
- (5) Pull two push-on hoses (4) through boom (9).
- (6) Remove two tee-jet diaphragms (5), two orifice discs (10), two hex nipples (11), and two adapters (12) from top of two rotary atomizer assemblies (3).
- (7) Remove two rotary atomizer assemblies (3) by removing four clamps (13).
- (8) Remove two hydraulic couplers (14) and two dust caps (15) from hydraulic hoses (1 and 2) at opposite end.
- (9) Remove two quick-release pins (16) and two cable assemblies (17) by removing two screws (18).

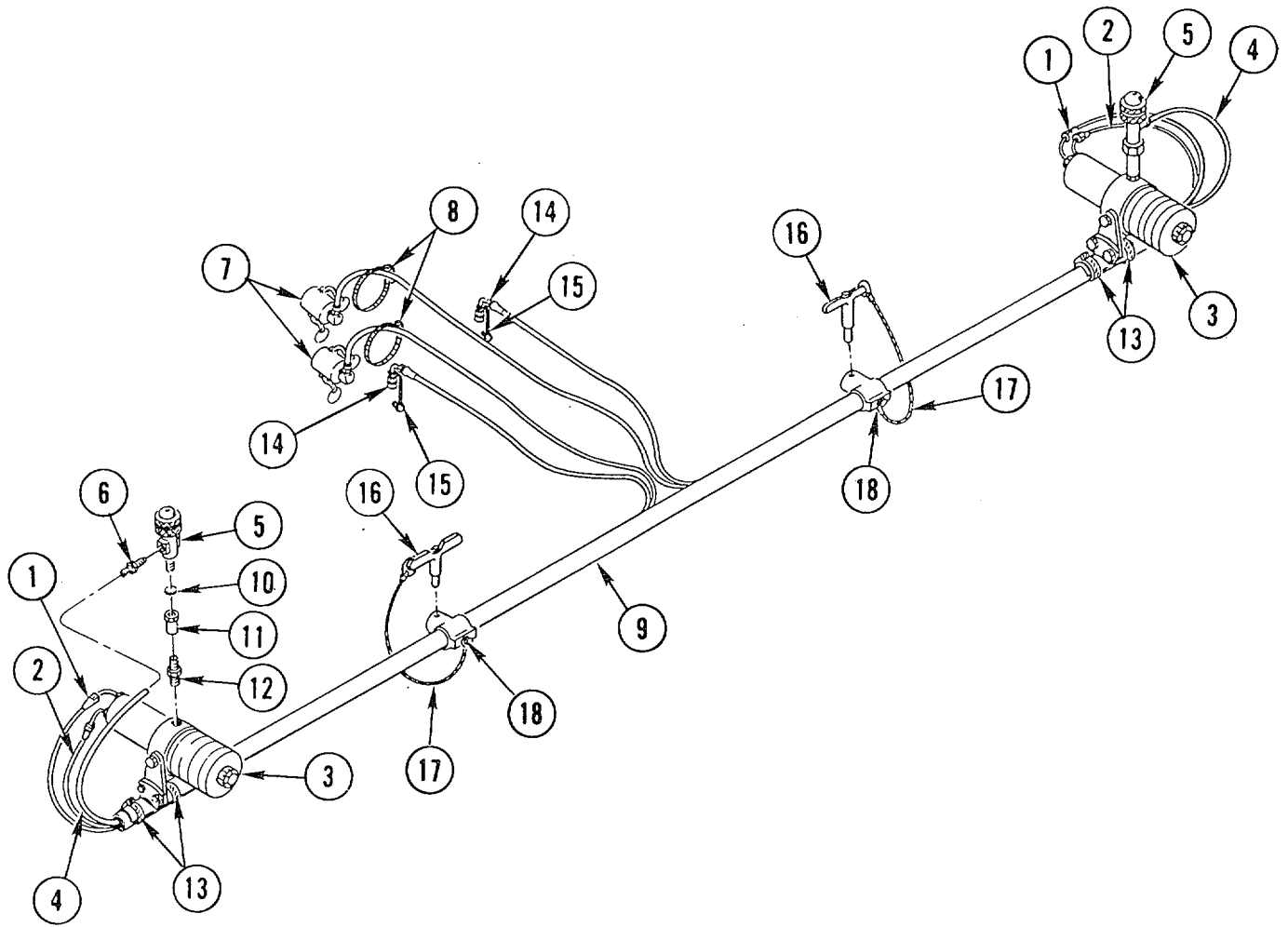



---

**ULV BOOM ASSEMBLY REPAIR (CONT)**

---

**C. ASSEMBLY**

- (1) Align two quick-release pins (1) and two cable assemblies (2) on boom (3) and secure with two screws (4).
- (2) Install two dust caps (5) and two hydraulic couplers (6) on ends of hydraulic hoses (7 and 8).
- (3) Install two rotary atomizer assemblies (9) and four clamps (10) on boom (3).
- (4) Install two adapters (11), two hex nipples (12), two orifice discs (13), and two tee-jet diaphragms (14) at top of each rotary atomizer assembly (9).
- (5) Install two fittings (15) at one end of two push-on hoses (16).
- (6) Lubricate two push-on hoses (16) with soap and water. Push through boom (3).
- (7) Install two clamps (17) and two cap assemblies (18) on two push-on hoses (16).
- (8) Connect two push-on hoses (16) to two tee-jet diaphragms (14).
- (9) Connect hydraulic hoses (7 and 8) to two rotary atomizer assemblies (9).

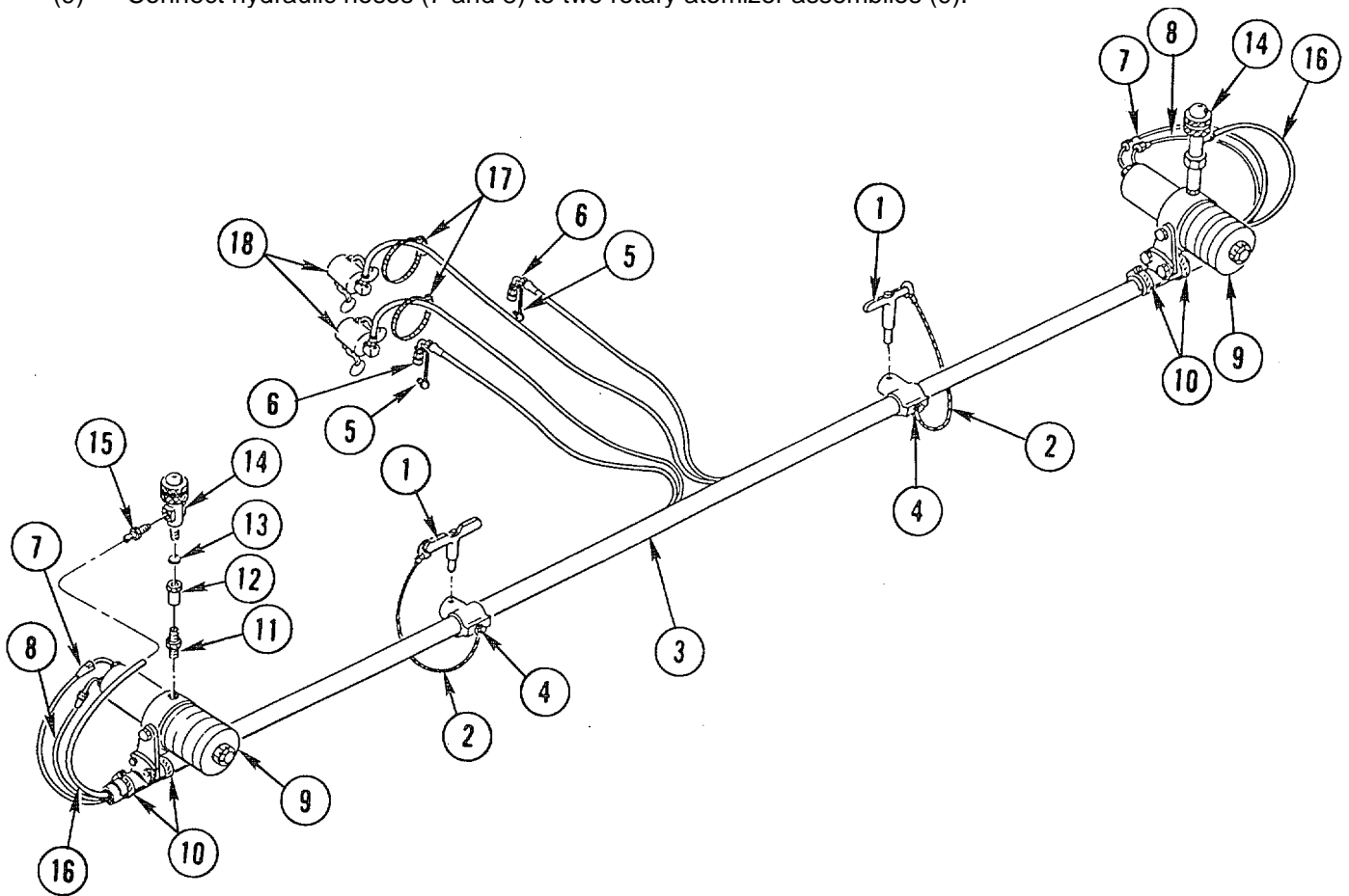

**4-50. ROTARY ATOMIZER ASSEMBLY REPAIR**

---

This task covers:      Disassembly      Assembly

---

**A. INITIAL SETUP**

**Tools and Special Equipment:**

Tool Kit, 5180-00-177-7033  
 Snap Ring Pliers  
 Plastic/Rubber Mallet

**Equipment Condition:**

<b>Reference</b>	<b>Condition Description</b>
Paragraph 4-49	Rotary Atomizer Assembly Removed from ULV Boom

**Materials/Parts:**

Seal, Front	Appendix E, Item 52
Seal, Plate	Appendix E, Item 50
Seal, Bearing	Appendix E, Item 5
Gasket, Motor	Appendix E, Item 18
Grease, Beeco Seal	Appendix E, Item 20

---

**ROTARY ATOMIZER ASSEMBLY REPAIR (CONT)**

---

**B. DISASSEMBLY**

- (1) Remove three screws (1) and cotter pin (2). Discard cotter pin.
- (2) Loosen castle nut (3) and unscrew at least three complete turns until end of shaft (4)s below top of castle nut (3).
- (3) Tap end of castle nut (3) with plastic or rubber mallet to release collet (5). When sleeve assembly (6) loosens, remove castle nut (3) and slide sleeve assembly (6) off shaft (4).
- (4) Remove collet (5), which will be on shaft end or inside sleeve assembly (6).

**CAUTION**

Snap ring will spring off shaft when removed. Be careful not to lose snap ring during removal.

- (5) Remove O-ring (7) from shaft (4). Slide front seal (8) off shaft (4).
- (6) Remove four screws (9) that secure disperser body (10) to motor assembly (11). Separate disperser body from motor assembly.
- (7) Using snap ring pliers, remove retaining ring (12) from outer end of disperser body (10).
- (8) Using screwdriver, rod, or dowel inserted against slotted end of shaft (4), tap lightly on shaft to drive shaft out of disperser body (10) outer end. Slide plate seal (13) off shaft (4).

**CAUTION**

Do not bend retaining ring when removing. Open retaining ring only enough to slide off shaft.

- (9) Using small snap ring pliers, remove retaining ring (14) from shaft (4).
- (10) Slide bearing support washer (15) off shaft (4). Use press or bearing puller to remove sealed bearing (16) from shaft (4).
- (11) Remove bearing seal (17) and impact washer (18) from disperser body (10).

**CAUTION**

Be careful to avoid bending motor assembly shaft when removing pin from coupling.

- (12) Provide rigid back support for coupling (19). Using drift pin, drive rear pin (20) out of coupling and remove coupling from motor assembly shaft (21).
- (13) Remove two screws (22) that secure transition plate (23) to motor assembly.
- (14) Remove transition plate (23) and motor gasket (24). Discard motor gasket.

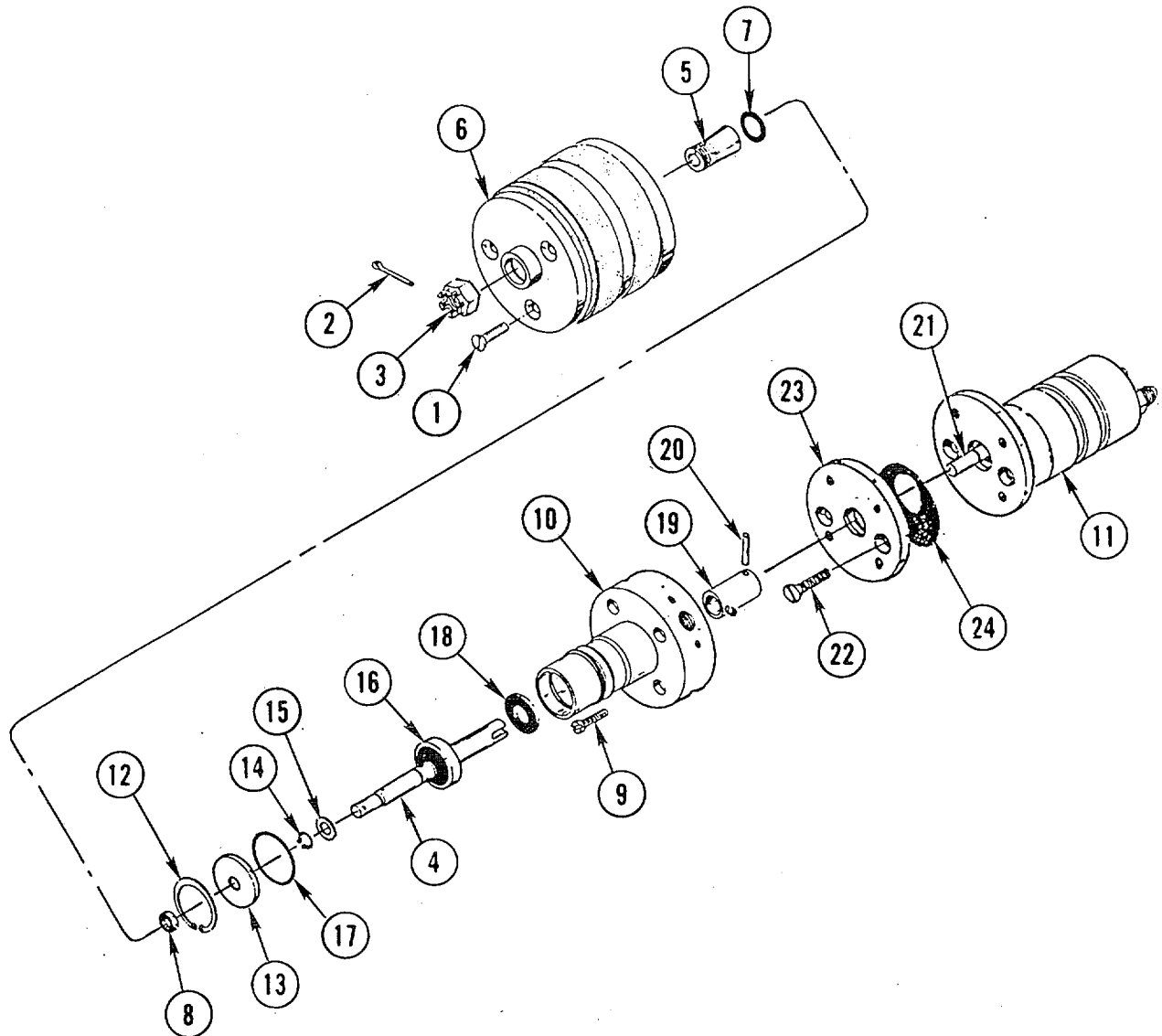

---

**ROTARY ATOMIZER ASSEMBLY REPAIR (CONT)**

---

**C. ASSEMBLY**

- (1) Install new motor gasket (1) on motor body (2). Secure transition plate (3) to motor using two screws (4)
- (2) Slide coupling (5) onto motor assembly shaft (6), aligning rear pin holes.
- (3) Install rear pin (7), ensuring pin ends are flush with coupling (5) outer surface. File off excess pin ends as required.
- (4) Install impact washer (8) on disperser body (9).
- (5) Slide disperser body (9) over coupling (5) and secure using four screws (10). Make sure shaft (11) slotted end slides over front pin in coupling.
- (6) Install sealed bearing (12) on shaft (11). Lower shaft and bearing assembly into disperser body (9) until sealed bearing (12) is fully seated.
- (7) Insert bearing seal (13) into disperser body (9) and push down around bearing outer race. Install bearing support washer (14).
- (8) Pack plate seal (15) recess with Beeco seal grease (item 20, Appendix E). Slide plate seal (15) down shaft (11) with recessed, greased side of plate seal toward sealed bearing (12).
- (9) Press plate seal (15) down to expose groove for retaining ring (16). Install retaining ring (16).
- (10) Position retaining ring (17) with flat surface against plate seal (15) and tapered surface facing up. Using small snap ring pliers, insert retaining ring (17) in disperser body (9) groove.
- (11) Install front seal (18) with thin lip of front seal facing plate seal (15). Install O-ring (19).
- (12) Push collet (20) onto shaft (11) until collet reaches stop. Verify that cotter pin (21) hole is exposed.
- (13) Slide sleeve assembly (22) on shaft (11) over collet (20) until threads can be seen. Make sure rear opening slips over disperser body (9).
- (14) Install three screws (23).
- (15) Install castle nut (24) and hand-tighten.
- (16) Using wrench, tighten castle nut (24) until slot on castle nut is aligned with cotter pin (21) hole. Install new cotter pin (21).

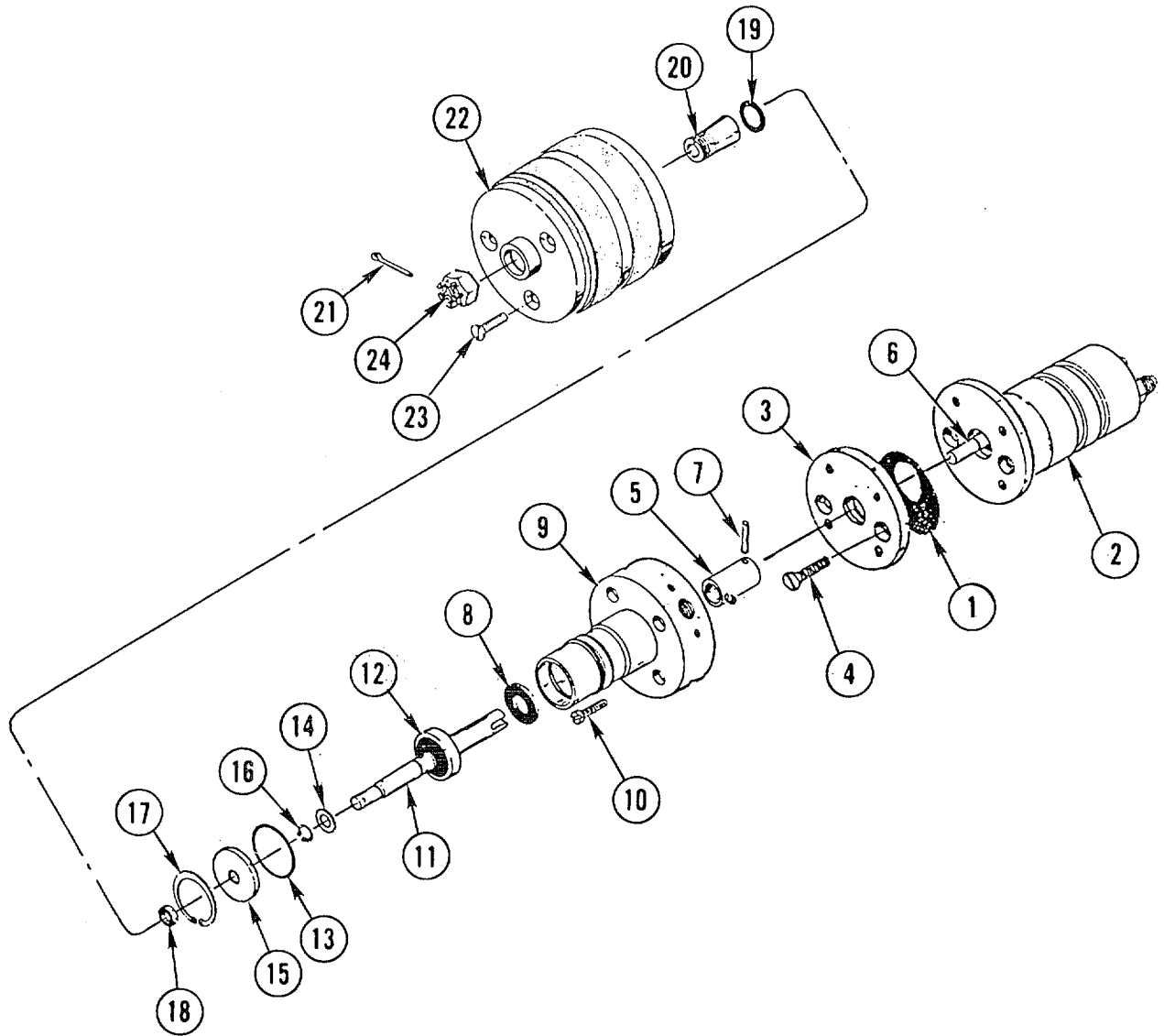

**4-51. MOTOR AND SLINGER ASSEMBLY REPLACEMENT**

---

This task covers:      Removal                      Installation

---

**A. INITIAL SETUP****Tools and Special Equipment:**

Tool Kit, 5180-00-177-7033

---

**B. REMOVAL**

- (1) Disconnect two 1/4-in. hydraulic hoses (1 and 2) at quick-disconnect fittings from back of secondary hydraulic manifold (3). Cap open lines.
- (2) Disconnect four 1/4-in. hydraulic hoses (4) at quick-disconnect fittings from two hopper cylinders (5). Cap open lines.
- (3) Disconnect 3/4-in. hose (6) from quick-disconnect fitting (7) on back of hydraulic filter. Cap open line.
- (4) Disconnect 1/2-in. hydraulic hose (8) from front bottom quick-disconnect fitting (9) on primary hydraulic manifold (10). Cap open line.
- (5) Support motor and slinger assembly (11) from underneath and remove four nuts (12), eight washers (13), and four screws (14) securing motor and slinger assembly (11) to engine platform (15). Remove motor and slinger assembly (11).

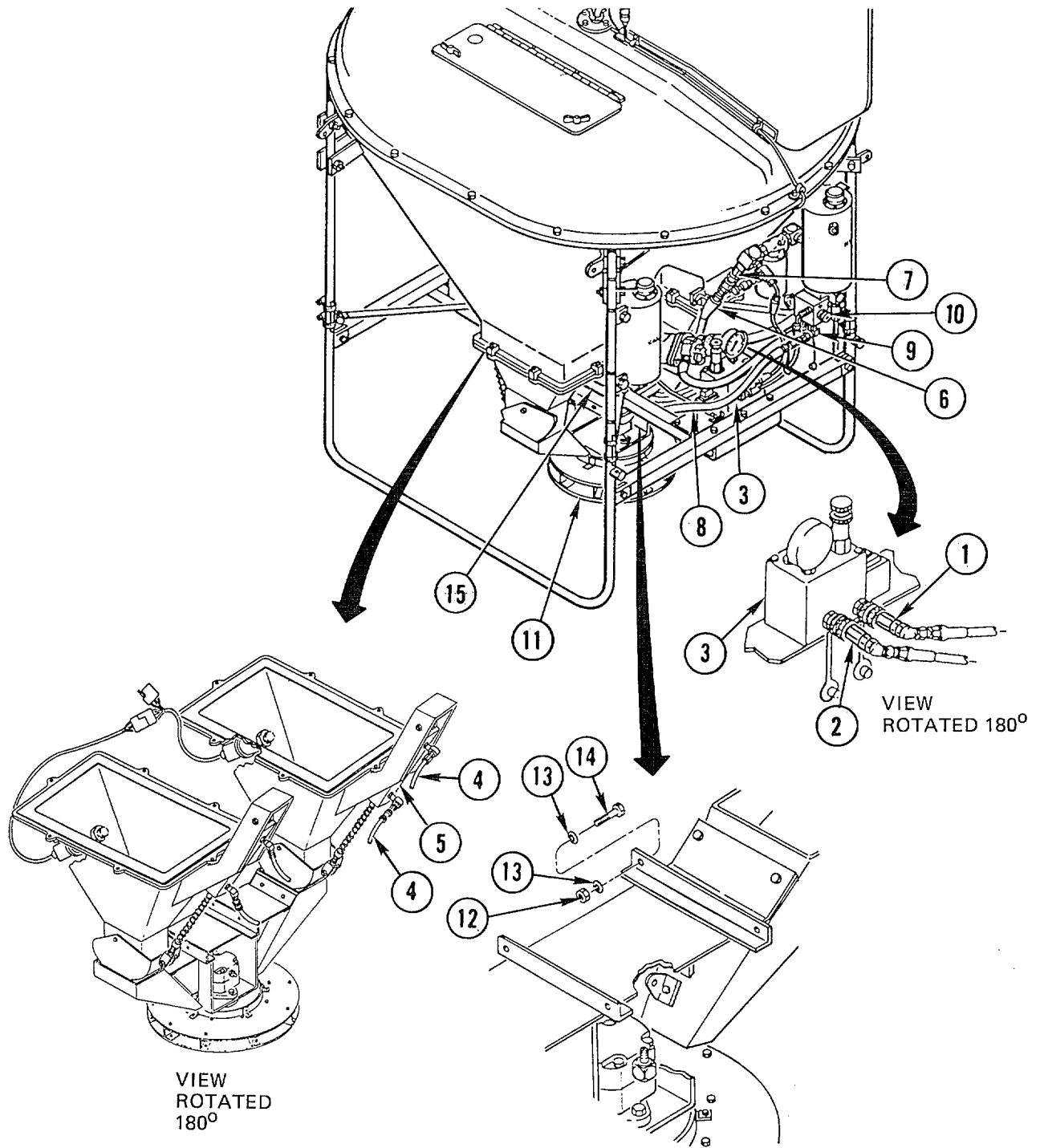



---

**MOTOR AND SLINGER ASSEMBLY REPLACEMENT (CONT)**

---

**C. INSTALLATION**

- (1) Install motor and slinger assembly (1) under bucket and secure to engine platform (2) with four screws (3), eight washers (4), and four nuts (5).
- (2) Using 3/8-in. open-end box-end wrench, loosen two chute inner bolts (6) to align and/or adjust chute up and down, and 3/8-in. socket-end wrench to loosen nut on lower bracket (7) to pivot slinger/chute assembly (8). This adjustment allows free motion of hopper and slinger.
- (3) Remove cap and connect 3/4-in. hose (9) to quick-disconnect fitting (10) on back of hydraulic filter.
- (4) Remove cap and route 1/2-in. hydraulic hose (11) under throttle cable and in front of secondary hydraulic manifold (12) and remove cap. Connect hose (11) to front bottom quick-disconnect fitting (13) on primary hydraulic manifold (14).
- (5) Remove caps and connect two 1/4-in. hydraulic fittings (15 and 16) to back of secondary hydraulic manifold (12), matching markings on fittings with markings on manifold.
- (6) Remove caps and connect four hydraulic fittings (17) to two hopper cylinders (18).
- (7) Spin slinger assembly (1) to ensure freedom of movement.

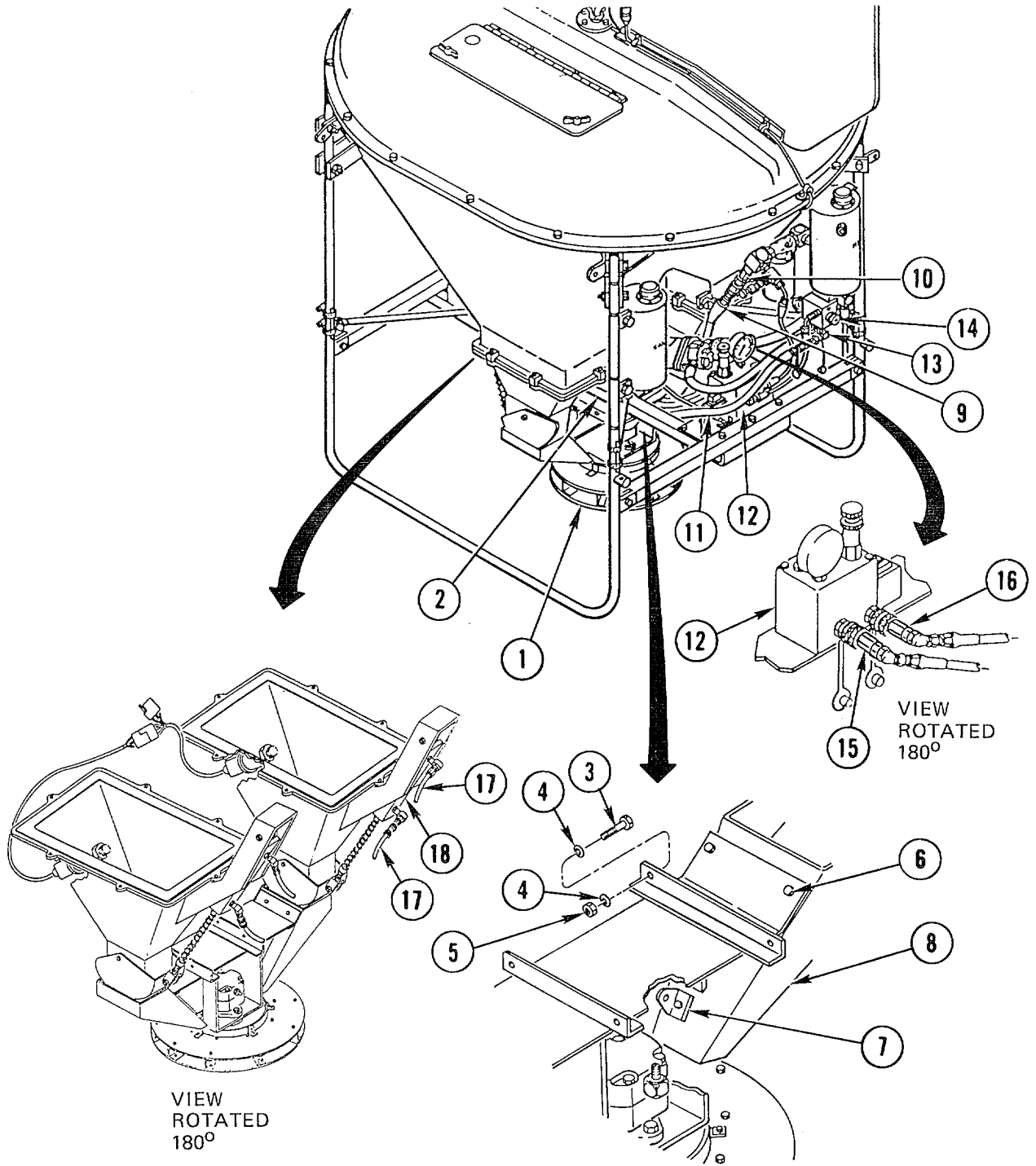

**4-52. MOTOR AND SLINGER ASSEMBLY REPAIR**

---

This task covers:      Disassembly      Assembly

---

**A. INITIAL SETUP**

**Tools and Special Equipment:**

Tool Kit, 5180-00-177-7033

**Equipment Condition:  
Reference**

Paragraph 4-51

**Condition Description**

Motor and Slinger  
Assembly Removed

---

**B. DISASSEMBLY**

- (1) Remove nut (1) and washer (2) that secure slinger (3) to slinger support weldment (4). Remove slinger (3).
- (2) Remove two nuts (5), two washers (6), two bolts (7), and two washers (8) that secure hydraulic motor (9) to pump housing (10) and slinger support weldment (4).
- (3) Remove hydraulic hoses (11 and 12) from fittings on hydraulic motor (9). Remove hydraulic motor (9).
- (4) Remove fittings (13 and 14) from hydraulic motor (9).
- (5) Remove chute assembly (15) by removing two screws (16) and two washers (17) from adjustable plate (18), and screw (19) and washer (20) from adjustment tab (21).

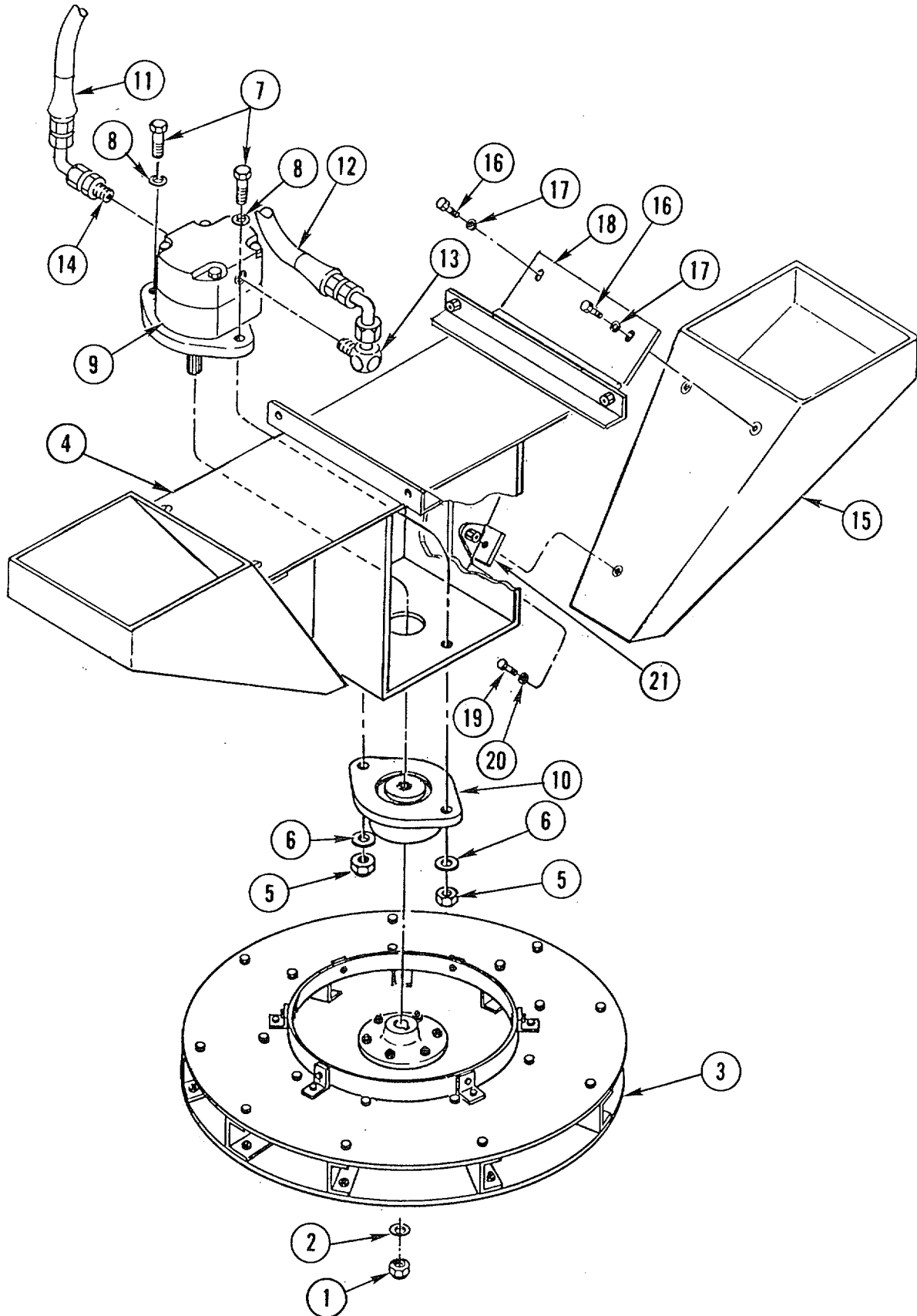

---

**MOTOR AND SLINGER ASSEMBLY REPAIR (CONT)**

---

**C. ASSEMBLY**

- (1) Align bottom part of chute assembly (1) with adjustment tab (2) and secure with washer (3) and screw (4).
- (2) Align top part of chute assembly (1) on adjustable plate (5) and secure with two washers (6) and two screws (7).
- (3) Install fittings (8 and 9) on hydraulic motor (10).
- (4) Align centrifuge pump housing (11) on slinger support weldment (12).
- (5) Install hydraulic motor (10) on slinger support weldment (12), aligning pump shaft with pump housing shaft.
- (6) Install two washers (13), two bolts (14), two washers (15), and two nuts (16) that secure hydraulic motor (10) to pump housing (11) and slinger support weldment (12).
- (7) Install hydraulic hoses (17 and 18) on hydraulic motor fittings (8 and 9).
- (8) Install slinger (19) on pump shaft and secure with washer (20) and nut (21).

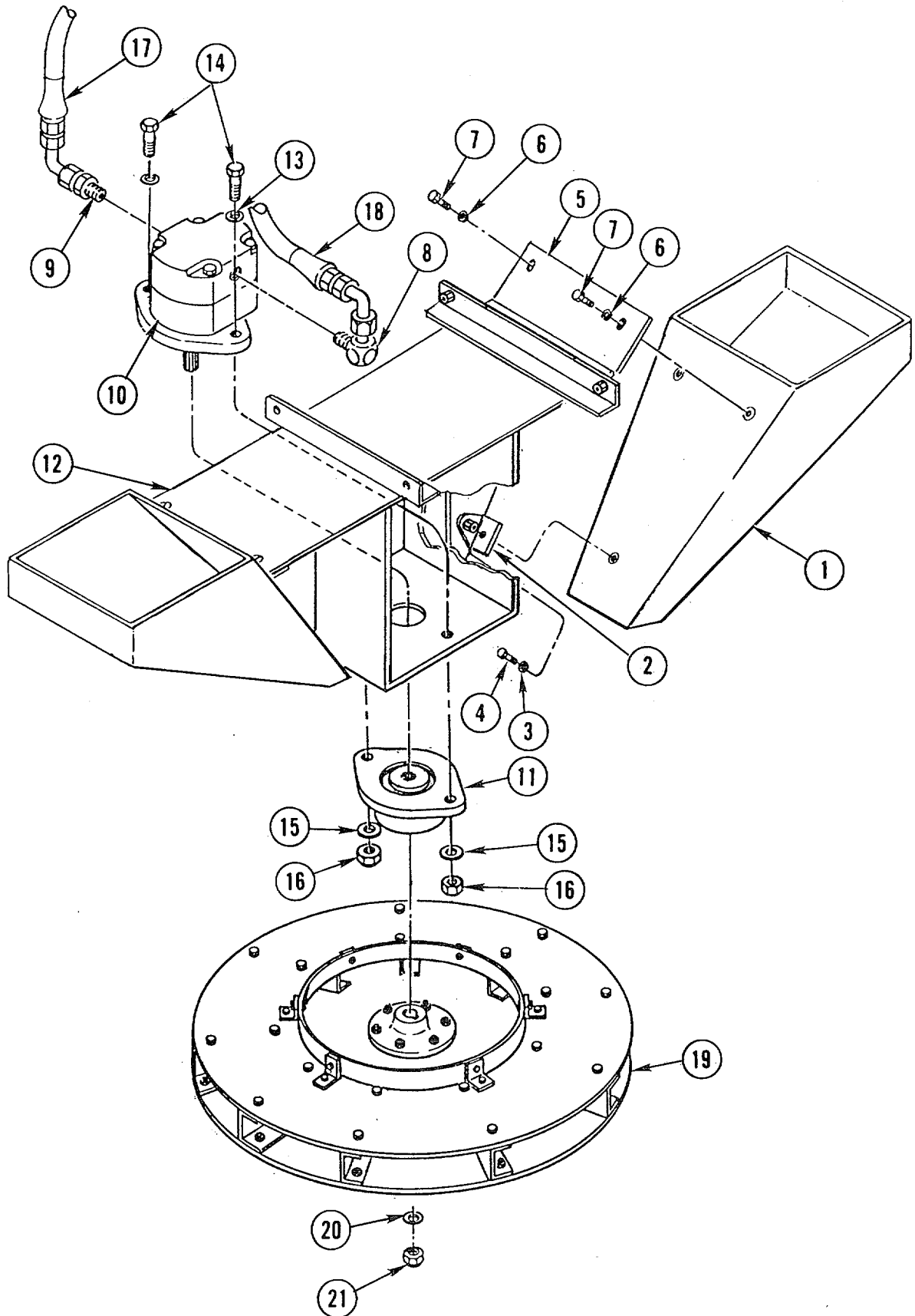

**4-53. HOPPER ASSEMBLY REPLACEMENT**

This task covers: Removal Installation

**A. INITIAL SETUP**

**Tools and Special Equipment:**

Tool Kit, 5180-00-177-7033

**Equipment Condition:**

Reference	Condition Description
Paragraph 4-51	Motor and Slinger Assembly Removed

**B. REMOVAL**

**NOTE**

Procedure is the same for left and right hopper assemblies, except step 1. Left hopper assembly capacitive light switch wiring harness has two 3-pole connectors for connection to right hopper assembly and bucket harness.

- (1) Disconnect left and right capacitive light switch wiring harnesses (1) from each other. If removing left hopper assembly, disconnect capacitive light switch wiring harness from bucket wiring harness.
- (2) Install suitable clamping device on downspout flanges and tighten enough to hold hopper assembly (2) to downspout.
- (3) Remove 6 nuts (3), 6 bolts (4), 12 lockwashers (5), and 6 clips (6).
- (4) Support hopper assembly (2) from underneath. Release clamps and remove hopper assembly from bucket.

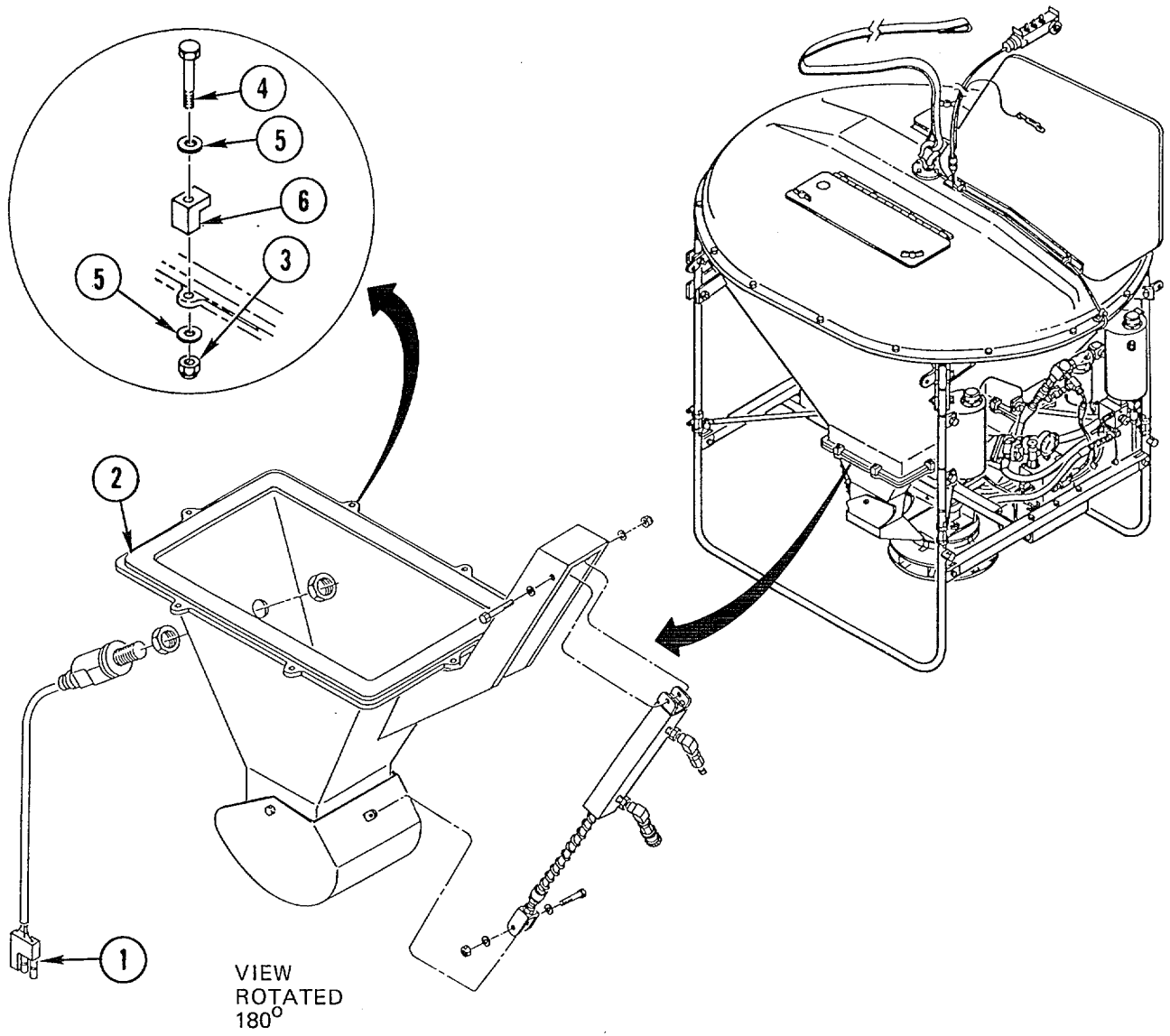



---

**HOPPER ASSEMBLY REPLACEMENT (CONT)**

---

**C. INSTALLATION****NOTE**

Procedure is the same for left and right hopper assemblies, except step 4. Left hopper assembly capacitive light switch wiring harness has two 3-pole connectors for connection to right hopper assembly and bucket harness.

Make sure both quick-disconnect fittings are pointing in 51 degrees toward center of bucket when hopper assembly is installed.

- (1) Install hopper assembly (1) under bucket with capacitive light switch toward rear, cylinder quick-disconnect fittings facing center under bucket, and cylinders toward front.
- (2) Align hopper assembly (1) mounting holes with downspout mounting holes. Install two suitable clamping devices on downspout flanges and tighten enough to hold hopper assembly (1) to downspout.
- (3) Secure hopper assembly (1) to bucket with 6 clips (2), 12 lockwashers (3), 6 bolts (4), and 6 nuts (5). Hand-tighten nuts (5) loosely until motor and slinger assembly has been installed and adjusted (para 4-51).
- (4) Connect left and right capacitive light switch wiring harnesses (6) to each other. If installing left hopper assembly, connect capacitive light switch wiring harness to bucket wiring harness.

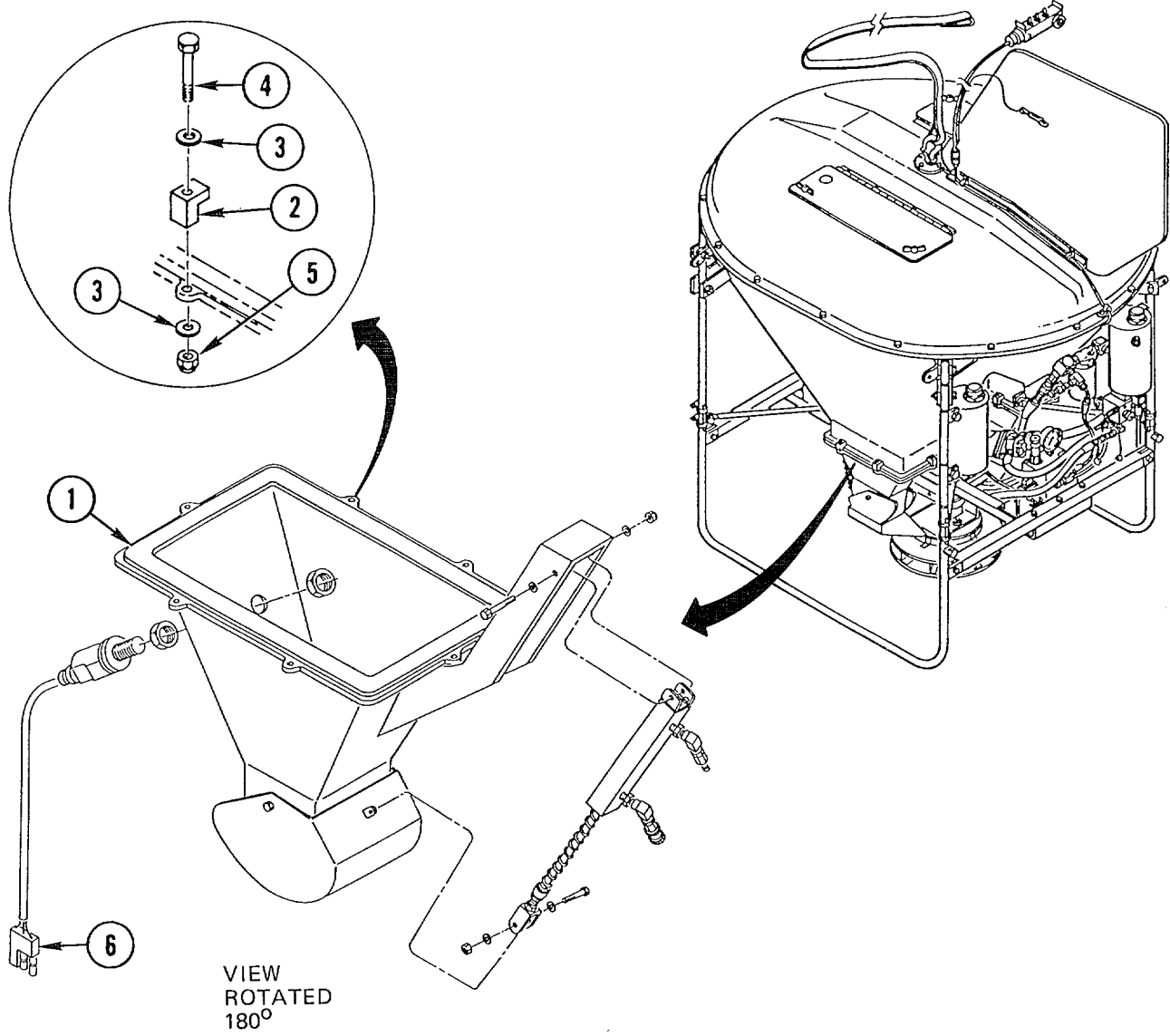

**4-54. HOPPER ASSEMBLY REPAIR**

This task covers: Disassembly Assembly

**A. INITIAL SETUP****Tools and Special Equipment:**

Tool Kit, 5180-00-177-7033

**Equipment Condition :****Reference**

Paragraph 4-53

**Condition Description**

Hopper Assembly

Removed

**Materials/Parts:**

Gasket Appendix E, Item 11

Contact Cement, Appendix E, Item 5

Barge All-Purpose

**B. DISASSEMBLY****NOTE**

Procedure is the same for left and right hopper assemblies. Left hopper assembly capacitive light switch wiring harness has two 3-pole connectors for connection to right hopper assembly and bucket harness.

- (1) Remove inner nut (1) from inside hopper assembly (2) and remove capacitive light switch (3).
- (2) Remove nut (4), screw (5), two washers (6), and cylinder assembly swivel bracket (7).
- (3) Remove nut (8), screw (9), and two washers (10) that secure cylinder assembly clevis (11) to chute (12).  
Remove cylinder assembly (13).
- (4) Remove dump valve gasket (14) from top of hopper assembly (2). Discard gasket.
- (5) Remove four socket head screws (15) holding base plate (16), spacer (17), flow control plate (18), and top plate (19) to bottom of hopper chute.
- (6) Remove two bolts (20) and two washers (21) to separate base plate (16), spacer (17), flow control plate (18), and top plate (19).

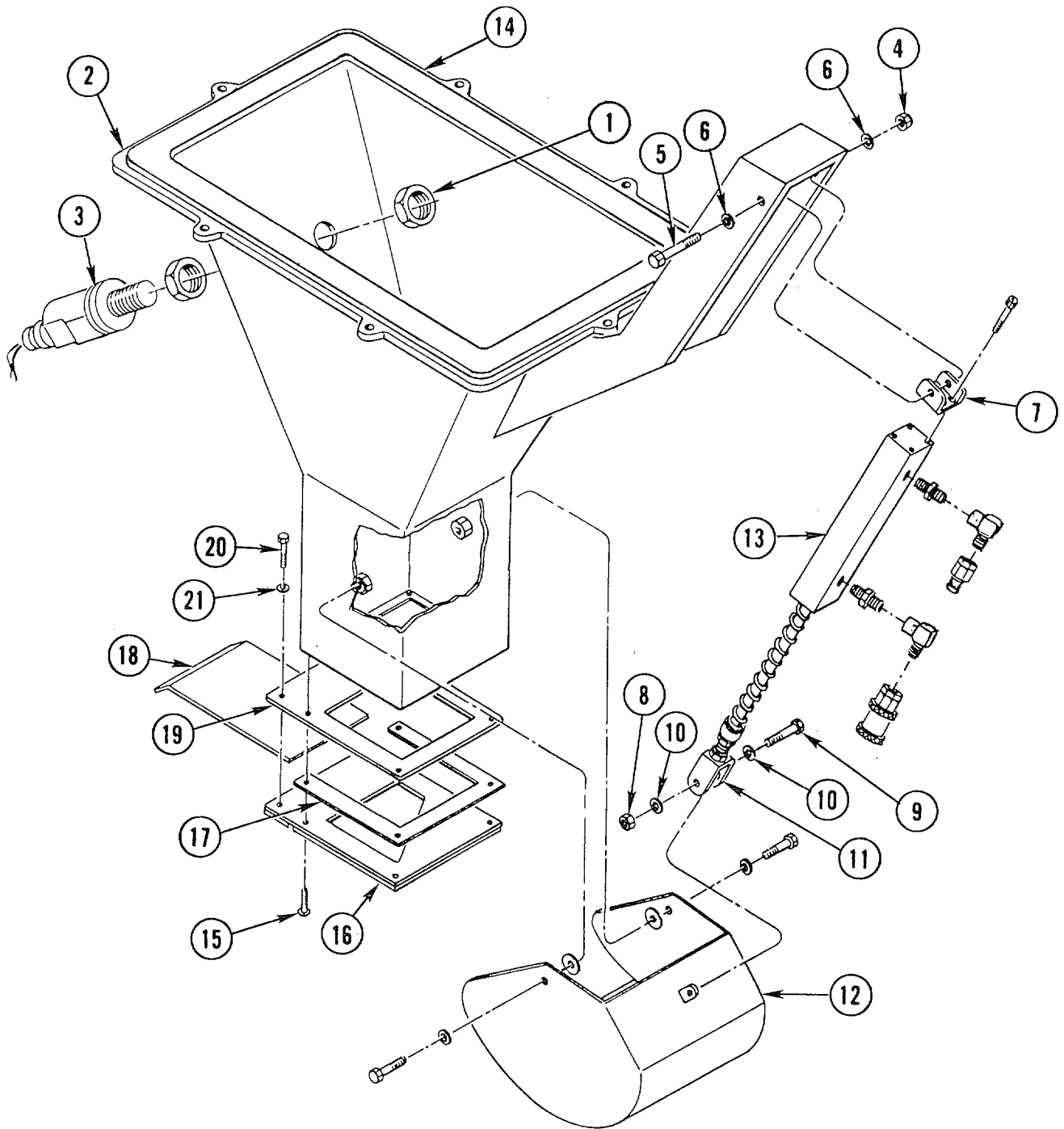

---

**HOOPER ASSEMBLY REPAIR (CONT)**

---

## C. Assembly

**NOTE**

Procedure is the same for left and right hopper assemblies. Left hopper assembly capacitive light switch wiring harness has two 3-pole connectors for connection to right hopper assembly and bucket harness.

- (1) Assemble top plate (1), flow control plate (2), spacer (3), and base plate (4). Install two bolts (5) and two washers (6).
- (2) Install top plate (1), flow control plate (2), spacer (3), and base plate (4) to bottom of hopper assembly (7) with four socket head screws (8).
- (3) Apply all-purpose contact cement (item 5, Appendix E) to new dump valve gasket (9) and install gasket on top of hopper assembly (7).
- (4) Align cylinder assembly clevis (10) on chute (11). Secure clevis (10) to chute (11) with two washers (12), screw (13), and nut (14).
- (5) Install cylinder assembly swivel bracket (15), two washers (16), screw (17), and nut (18).
- (6) Make sure both quick-disconnect fittings on cylinder assembly (19) will be pointing in 51 degrees toward center when hopper assembly (7) is installed.
- (7) Thread outer nut 3/4-in. onto shank of capacitive light switch (20). Make sure enough thread is left for inner nut (21).
- (8) Insert capacitive light switch (20) through opening in hopper assembly (7). Install and hand-tighten inner nut (21).
- (9) Use wrench to tighten inner nut (21) 1/8 turn.

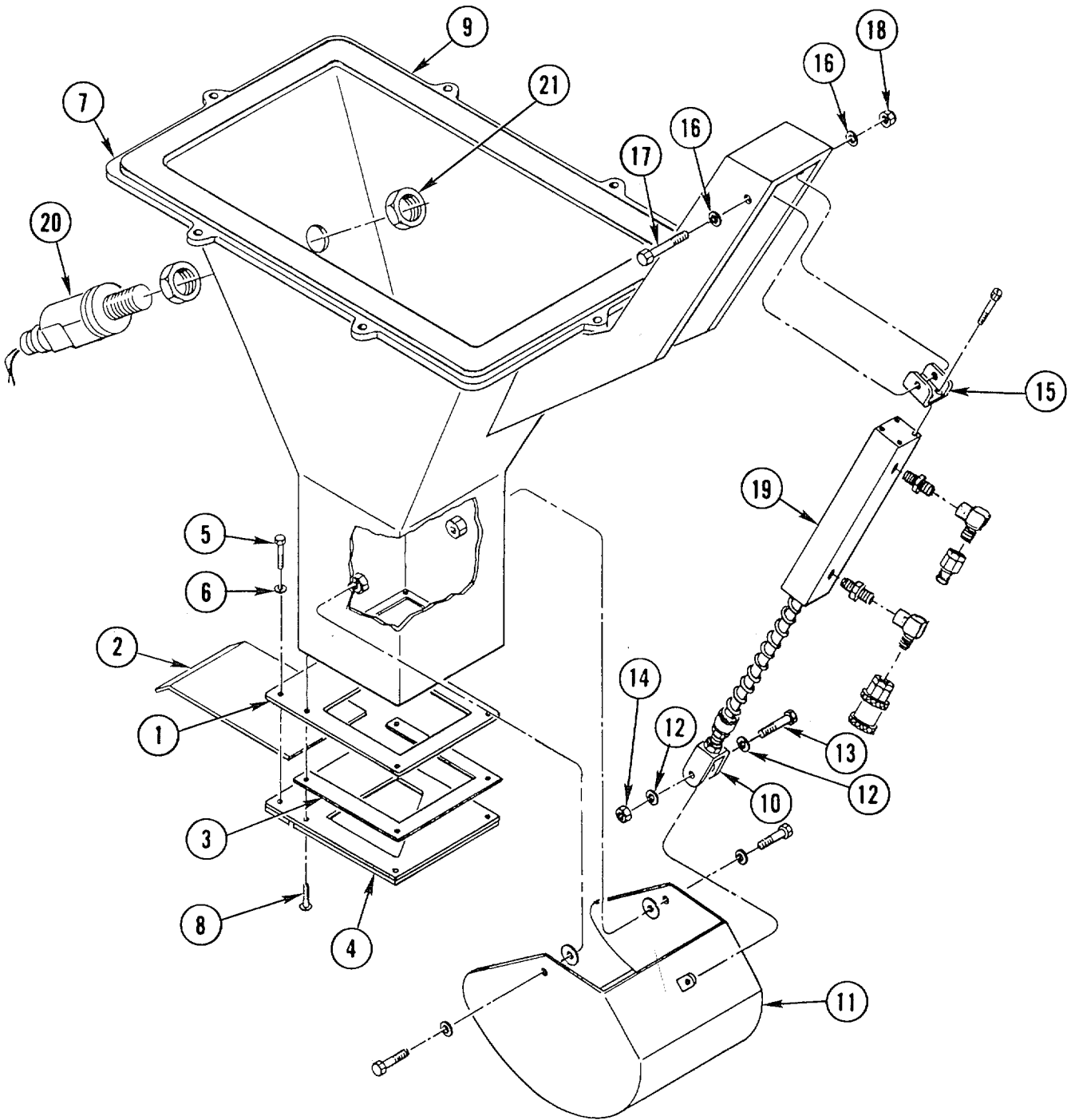

**4-55. DOLLY ASSEMBLY REPLACEMENT**

This task covers: Removal Installation

**A. REMOVAL**

- (1) Attach suitable lifting device to hook assembly (1).
- (2) Push four levers (2) to release bucket leg weldments (3).

**WARNING**

Assembled PDU is very heavy. Use suitable lifting device and clear area.  
Do not allow personnel to stand under or near raised unit to prevent personal injury.

- (3) Lift dispersal unit (4) from dolly assembly (5).
- (4) Lower dispersal unit (4) to solid level surface.
- (5) Remove lifting device from hook assembly (1).

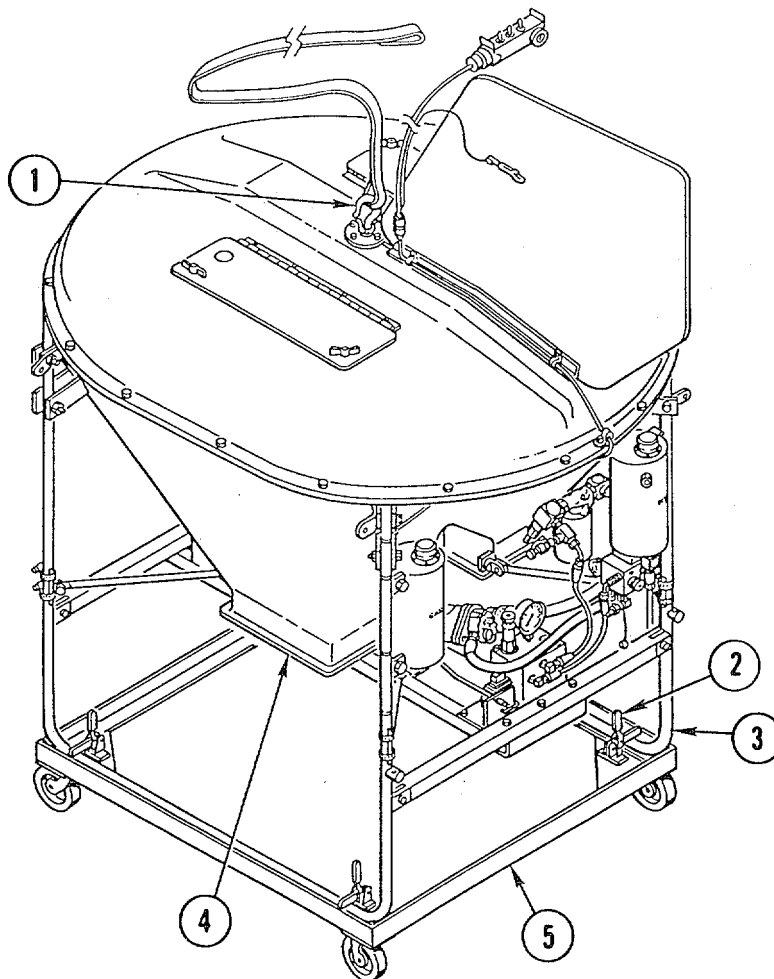

**B. INSTALLATION****WARNING**

Assembled PDU is very heavy. Use suitable lifting device and clear area.  
Do not allow personnel to stand under or near raised unit to prevent personal injury.

- (1) Attach suitable lifting device to hook assembly (1).
- (2) Align dispersal unit (2) and lower carefully onto dolly assembly (3).
- (3) Pull four levers (4) to secure bucket leg weldments (5).
- (4) Remove lifting device from hook assembly (1).

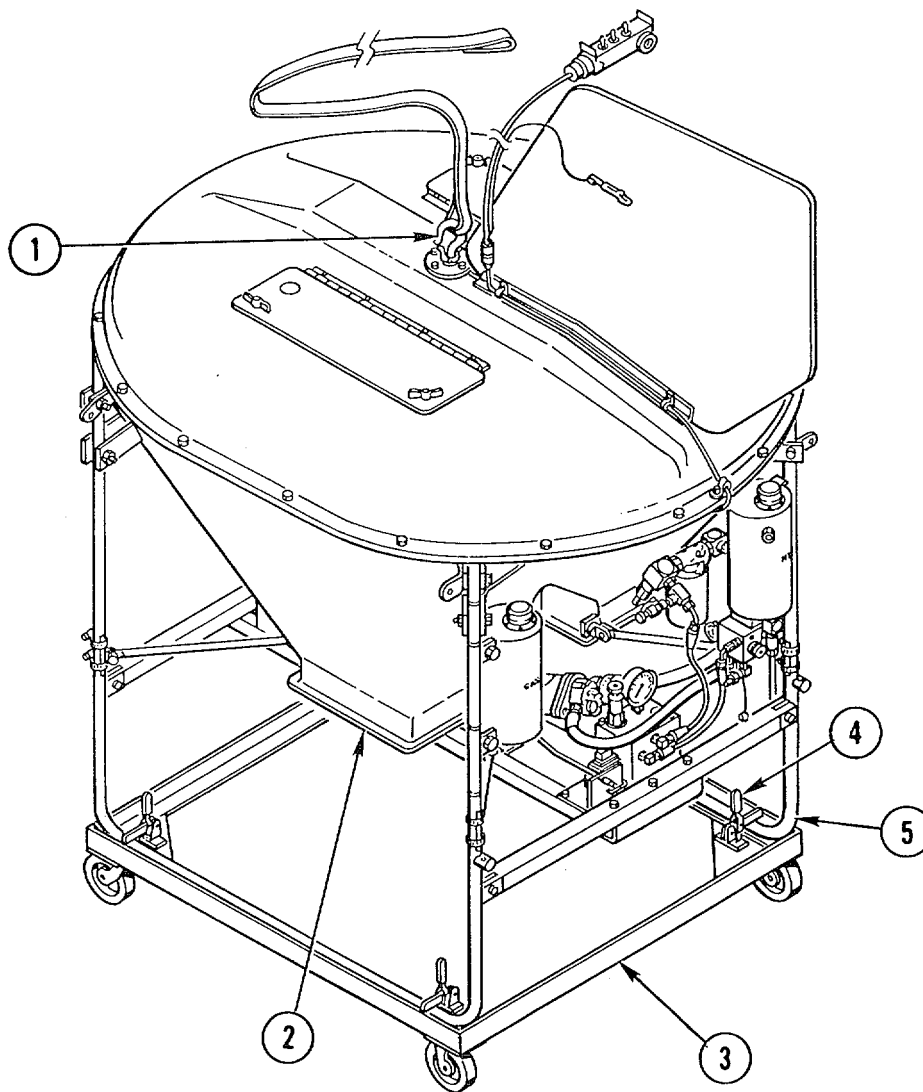



**4-56. DOLLY ASSEMBLY REPAIR**

This task covers: Disassembly Assembly

**A. INITIAL SETUP****Tools and Special Equipment:**

Tool Kit, 5180-00-177-7033

**B. DISASSEMBLY**

Remove 4 swivel casters (1) from dolly weldment (2) by removing 16 nuts (3), 16 washers (4), 16 bolts (5), and 16 washers (4).

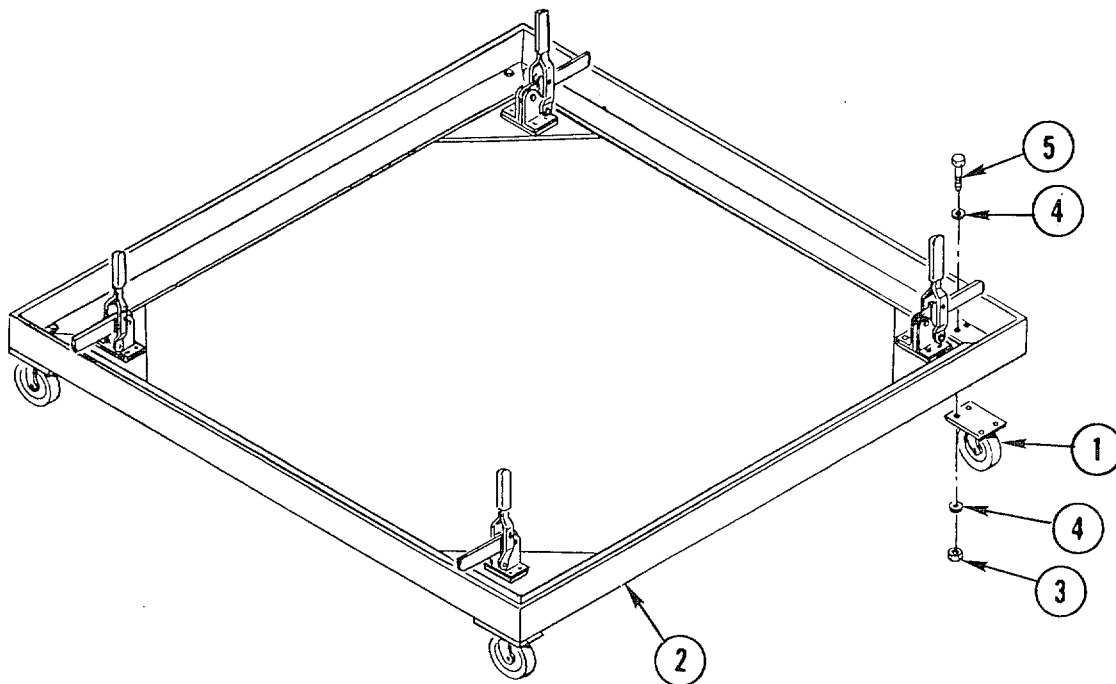
**C. ASSEMBLY**

Align 4 swivel casters (1) on dolly weldment (2) and install 16 washers (4), 16 bolts (5), 16 washers (4), and 16 nuts (3).

**Section VI. PREPARATION FOR STORAGE OR SHIPMENT****4-57. PREPARATION FOR STORAGE OR SHIPMENT**

If the original packing material was saved, pack the equipment in the same manner as when received. When using packing materials other than original, use the following guidelines:

- a. Insert PDU in its crate.
- b. Insert hand control and manual into waterproof bag.
- c. Use plenty of shock-absorbing material all around hand control to protect against damage, and insert into suitable size container.

**4-58. SPECIAL INSTRUCTIONS FOR ADMINISTRATIVE STORAGE****CAUTION**

For storage over 1 week, disconnect battery. Battery drain will occur if not disconnected.

- a. Placement of equipment in administrative storage should be for short periods of time when a shortage of maintenance efforts exists. Items should be in mission readiness within 24 hours or within the time factors as determined by the directing authority. During the storage period appropriate maintenance records will be kept.
- b. Before placing equipment in administrative storage, current maintenance services and Equipment Serviceable Criteria (ESC) evaluations should be completed, shortcomings and deficiencies should be corrected, and all Modification Work Orders (MWO's) should be applied.
- c. Storage site selection. Inside storage is preferred for items selected for administrative storage. If inside storage is not available, trucks, vans, conex containers and other containers may be used.

**CHAPTER 5  
DIRECT SUPPORT MAINTENANCE INSTRUCTIONS**

	Para	Page
Common Tools and Equipment .....	5-1	5-1
Engine and Pump Assembly Hydraulic Pump Assembly Repair.....	5-8	5-17
Hand Control Assembly Repair .....	5-11	5-33
Hydraulic Motor Repair .....	5-13	5-41
Key Switchbox Assembly Repair .....	5-5	5-8
Primary Hydraulic Manifold Assembly Repair.....	5-10	5-27
Pump and Crosstube Assembly Chemical Pump Repair.....	5-12	5-38
Pump and Crosstube Assembly Spray System Control Repair .....	5-14	5-46
Repair Parts .....	5-3	5-1
Secondary Hydraulic Manifold Assembly Repair .....	5-9	5-22
Special Tools, TMDE, and Support Equipment .....	5-2	5-1
Starter Motor Repair .....	5-7	5-14
Starter Motor Replacement .....	5-6	5-12
Troubleshooting Procedures .....	5-4	5-2

**Section I. REPAIR PARTS, SPECIAL TOOLS; TEST,  
MEASUREMENT, AND DIAGNOSTIC EQUIPMENT (TMDE); AND  
SUPPORT EQUIPMENT**

**5-1. COMMON TOOLS AND EQUIPMENT**

For authorized common tools and equipment, refer to the Modified Table of Organization and Equipment (MTOE) at your unit.

**5-2. SPECIAL TOOLS, TMDE, AND SUPPORT EQUIPMENT**

Special tools required for direct support maintenance are listed in the Maintenance Allocation Chart (Appendix B) and the Repair Parts and Special Tools List (Appendix F).

**5-3. REPAIR PARTS**

Repair parts for the Pesticide Dispersal Unit, Multicapability, Helicopter Slung (PDU) are listed and illustrated in the Repair Parts and Special Tools List (Appendix F).

**Section II. SERVICE UPON RECEIPT**

Inspect equipment for damage incurred during shipment. If equipment has been damaged, report damage on SF-364, Report of Discrepancy.

Check equipment against packing slip to see if shipment is complete. Report all discrepancies in accordance with instructions in DA Pam 738-750.

**Section III. TROUBLESHOOTING**

**5-4. TROUBLESHOOTING PROCEDURES**

The troubleshooting procedures listed in table 5-1 are those that may be done by direct support level personnel. Problems that may arise during operation or maintenance of the PDU or its components are listed under Malfunction. Tests or Inspections to conduct and Corrective Actions to take to repair the malfunction follow. Perform the tests/inspections and corrective actions in the order listed. This manual cannot list all malfunctions that may occur, nor all tests or inspections and corrective actions. If a malfunction is not listed or is not corrected by listed corrective actions, notify your supervisor.

**SYMPTOM INDEX**

<b>Symptom</b>	<b>Page</b>
1. ENGINE FAILS TO START .....	5-3
2. NO HYDRAULIC PRESSURE TO PRIMARY MANIFOLD .....	5-5
3. UNABLE TO MAINTAIN HYDRAULIC PRESSURE IN PRIMARY MANIFOLD .....	5-5
4. NO PRESSURE/UNABLE TO MAINTAIN HYDRAULIC PRESSURE IN SECONDARY MANIFOLD .....	5-5
5. SLINGER WILL NOT ROTATE .....	5-6
6. CHEMICAL PUMP WILL NOT DISPERSE PESTICIDE .....	5-6
7. SPRAY SYSTEM CONTROL VALVE DOES NOT OPEN .....	5-6
8. HAND CONTROL UNRESPONSIVE .....	5-7

Table 5-1. Direct Support Troubleshooting

Malfunction	Test or Inspection	Corrective Action
-------------	--------------------	-------------------

## ENGINE AND PUMP ASSEMBLY

## 1. ENGINE FAILS TO START.

**WARNING**

Failure to disconnect battery can result in personal injury or damage to equipment.

## Step 1. Check for defective key switchbox.

- Disconnect battery.
- Set engine switch to OFF position.
- Inspect for loose, broken, or missing wires or blown fuse inside key switchbox. Tighten, repair, or replace wires or blown fuse (para 5-5).
- Check continuity of oil level switch:  
With multimeter set to ohms scale, measure resistance between black and yellow leads, black lead to ground, and yellow lead to ground. Readings should not exceed 0.1 ohm. If readings exceed 0.1 ohm, replace key switchbox (para 5-5).
- Check continuity of key switch:  
With multimeter set to ohms scale, measure resistance between black and green leads, yellow and green leads, and yellow lead to ground. Readings should not exceed 4 K ohms. If readings exceed 4 K ohms, replace key switchbox (para 5-5).
- Set engine switch to ON position.
- Check continuity of oil level switch:  
With multimeter set to ohms scale, measure resistance between black and yellow leads. If reading exceeds 0.1 ohm, replace key switchbox (para 5-5).  
With multimeter set to ohms scale, measure resistance between black lead and ground, and yellow lead and ground. If readings are not 1 M ohm minimum, replace key switchbox (para 5-5).
- Check continuity of key switch:  
With multimeter set to ohms scale, measure resistance between green lead and ground. If reading exceeds 4 K ohms, replace key switchbox (para 5-5).

Table 5-1. Direct Support Troubleshooting (Cont)

Malfunction	Test or Inspection	Corrective Action
-------------	--------------------	-------------------

- Check oil level and key switches for continuity between pins 1-2, 1-4, 1-5, 2-4, and 4-5. There should be no continuity between pins 1-3, 2-3, 2-5, 3-4, 3-5. With multimeter set to ohms scale, measure resistance between black and green leads, and yellow and green leads. If readings exceed 1 M ohm, replace key switchbox (para 5-5). With multimeter set to ohms scale, check for continuity in one direction. If reading shows continuity in both directions, replace rectifier (para 5-5).

Step 2. Check for defective starter motor.

**WARNING**

Be careful not to contact high-voltage connections when installing or operating this equipment.

**NOTE**

Cranking under load indicates hydraulic pump installed on engine. Cranking with no load indicates hydraulic pump removed from engine.

- Connect battery.
- With multimeter set to read 12 VDC, measure cranking voltage under load across starter leads. Reading should be 9.9 VDC. Measure cranking voltage with no load. Reading should be 11.5 VDC. If starter motor fails to meet performance voltage readings, repair or replace starter motor (para 5-7 or 5-6).
- With multimeter set to read amps, measure cranking amperage under load. Reading should be below 103 amps. Measure cranking amperage with no load. Reading should be below 31 amps. If starter fails to meet performance amperage readings, repair or replace starter motor (para 5-7 or 5-6).
- With multimeter set to read 12 VDC, check for 12 VDC between starter terminal and solenoid terminal. If no voltage is present, replace starter motor (para 5-6).
- Measure length of starter motor brushes. Length should be 0.14-0.28 in. (3.5 mm-7.0 mm). If brush length is inadequate, replace brushes (para 5-7).

Table 5-1. Direct Support Troubleshooting (Cont)

Malfunction	Test or Inspection	Corrective Action
2. NO HYDRAULIC PRESSURE TO PRIMARY MANIFOLD.	Check for defective hydraulic pump.	<ul style="list-style-type: none"> <li>If hydraulic pump is excessively noisy, replace hydraulic pump (para 5-8).</li> </ul>
3. UNABLE TO MAINTAIN HYDRAULIC PRESSURE IN PRIMARY MANIFOLD.	Step 1. Check for defective pressure gage.	<ul style="list-style-type: none"> <li>If hydraulic pressure is present at primary manifold but gage has no indication, replace pressure gage (para 5-10).</li> </ul>
	Step 2. Check for defective primary manifold solenoid.	<ul style="list-style-type: none"> <li>With multimeter set to ohms scale, measure resistance between solenoid terminals. Reading should be 4-10 ohms. If reading is less than 4-10 ohms, replace solenoid (para 5-10).</li> </ul>
	Step 3. Check for operation of flow regulator.	<ul style="list-style-type: none"> <li>If unable to adjust flow, replace flow regulator (para 5-10).</li> </ul>
	Step 4. Check for defective primary manifold.	<ul style="list-style-type: none"> <li>If pressure drops steadily on pressure gage, repair or replace primary manifold (para 5-10).</li> </ul>
4. NO PRESSURE/UNABLE TO MAINTAIN HYDRAULIC PRESSURE IN SECONDARY MANIFOLD.	Step 1. Check for defective hydraulic pressure gage.	<ul style="list-style-type: none"> <li>If hydraulic pressure is present at secondary manifold but gage has no indication, replace pressure gage (para 5-9).</li> </ul>
	Step 2. Check for defective secondary manifold solenoid.	<ul style="list-style-type: none"> <li>With multimeter set to ohms scale, measure resistance between solenoid terminals. Reading should be 8-9 ohms. If reading is less than 8-9 ohms, replace solenoid (para 5-9).</li> </ul>
	Step 3. Check for operation of flow regulator.	<ul style="list-style-type: none"> <li>If unable to adjust flow, replace flow regulator (para 5-9).</li> </ul>

Table 5-1. Direct Support Troubleshooting (Cont)

Malfunction	Test or Inspection	Corrective Action
		<p>Step 4. Check for defective secondary manifold.</p> <ul style="list-style-type: none"> <li>• If pressure drops steadily on pressure gage, repair or replace secondary manifold (para 5-9).</li> </ul> <p>Step 5. If problem still exists, perform test or inspection procedure in Malfunction 3.</p>
<b>SOLID DISPERSAL SYSTEM</b>		
<b>5. SLINGER WILL NOT ROTATE.</b>		
		<p>Step 1. Check for debris between slinger and hopper assembly.</p> <ul style="list-style-type: none"> <li>• Remove debris.</li> </ul> <p>Step 2. Check for Class III hydraulic leaks at motor shaft and fittings.</p> <ul style="list-style-type: none"> <li>• Tighten fittings or repair hydraulic motor (para 5-13).</li> </ul> <p>Step 3. Check for operation of hydraulic motor.</p> <ul style="list-style-type: none"> <li>• If hydraulic motor shaft does not rotate by hand, repair hydraulic motor (para 5-13).</li> </ul>
<b>LIQUID DISPERSAL SYSTEMS</b>		
<b>6. CHEMICAL PUMP WILL NOT DISPERSE PESTICIDE.</b>		
		<p>Step 1. Check for excessively noisy chemical pump.</p> <ul style="list-style-type: none"> <li>• Replace or repair chemical pump (para 5-12).</li> </ul> <p>Step 2. Check that chemical pump shaft rotates freely.</p> <ul style="list-style-type: none"> <li>• If shaft does not rotate, replace or repair chemical pump (para 5-12).</li> </ul>
<b>7. SPRAY SYSTEM CONTROL VALVE DOES NOT OPEN.</b>		
		<p>Step 1. Check for missing or defective flapper or ball installed backwards.</p> <ul style="list-style-type: none"> <li>• Repair control valve (para 5-14).</li> </ul> <p>Step 2. Check for operation of spray system control valve.</p> <ul style="list-style-type: none"> <li>• Replace or repair spray system control valve (para 5-14).</li> </ul>



Table 5-1. Direct Support Troubleshooting (Cont)

---

Malfunction
Test or Inspection
Corrective Action

---

## LIQUID AND SOLID DISPERSAL SYSTEMS

## 8. HAND CONTROL UNRESPONSIVE.

Step 1. Check for broken, loose, or missing wires or connectors.

- Replace or repair hand control (para 5-11).

Step 2. Check for inoperative switches.

- Replace switches (para 5-11).

Step 3. Check for burned out LEDs or missing lenses.

- Repair hand control assembly (para 5-11).
-

**Section IV. DIRECT SUPPORT MAINTENANCE PROCEDURES**

**5-5. KEY SWITCHBOX ASSEMBLY REPAIR**

This task covers: Disassembly Assembly

---

**A. INITIAL SETUP**

**Tools and Special Equipment:**

Tool Kit, 5180-00-177-7033  
 Shop Equipment, 4910-00-754-0654

**Reference**  
 Paragraph 4-16

**Equipment Condition:**

**Condition Description**  
 Key Switchbox  
 Removed

**Materials/Parts:**

Grommet	Appendix E, Item 23
Receptacle, Female	Appendix E, Item 48
Plug, Snap, Male	Appendix E, Item 47

Key Removed

---

**B. DISASSEMBLY**

**NOTE**

Tag electrical leads prior to removal to aid in installation.

- (1) Remove switchbox assembly front panel (1) by removing four screws (2).
- (2) Remove rectifier assembly (3) by removing two nuts (4), two washers (5), and two bolts (6).
- (3) Disconnect electrical leads (7) from fuseholder (8), key switch (9), and oil switch (10).
- (4) Remove two female snap plugs (11). Discard snap plugs.
- (5) Remove four male snap plugs (12). Discard snap plugs.
- (6) Withdraw electrical leads (7) and remove grommet (13). Discard grommet.
- (7) Remove nut (14) and fuseholder (8).
- (8) Remove nut (15) and key switch (9).
- (9) Remove oil switch (10) by removing nut (16), lockwasher (17), and screw (18).

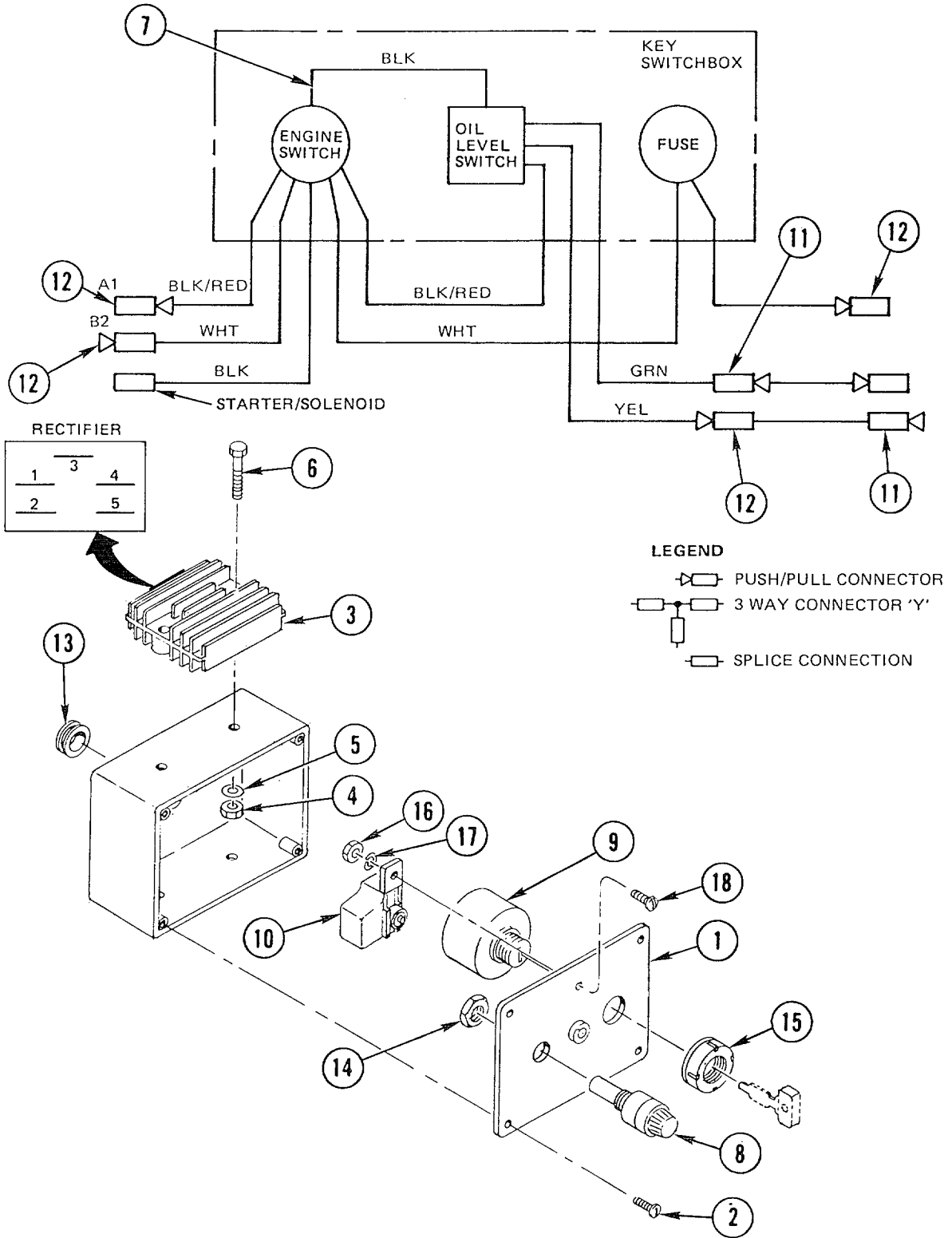

---

**KEY SWITCHBOX ASSEMBLY REPAIR (CONT)**

---

**C. ASSEMBLY**

- (1) Install oil switch (1) to switchbox assembly front panel (2) by installing screw (3), lockwasher (4), and nut (5).
- (2) Insert key switch (6) through opening in front panel and secure with nut (7).
- (3) Insert fuseholder (8) through opening in front panel and secure with nut (9).
- (4) Install new grommet (10).
- (5) Attach four new male snap plugs (11).
- (6) Attach two new female snapplugs (12).
- (7) Run electrical leads (13) through grommet (10) and connect to fuseholder (8), key switch (6), and oil switch (1).
- (8) Align rectifier assembly (14) and install two bolts (15), two washers (16), and two nuts (17).
- (9) Align switchbox assembly front panel (2) and install four screws (18).

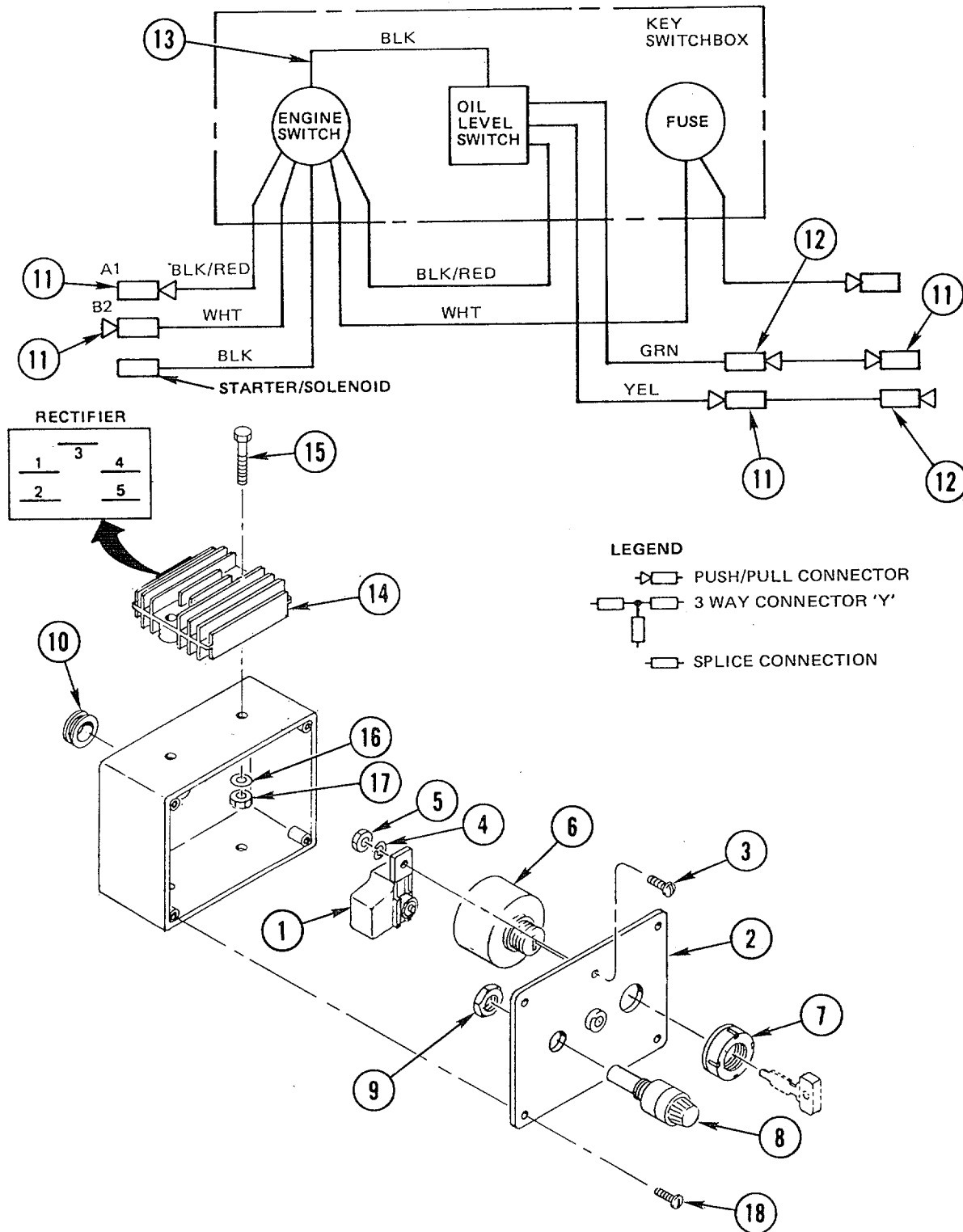

**5-6. STARTER MOTOR REPLACEMENT**

This task covers: Removal Installation

---

**A. INITIAL SETUP**

**Tools and Special Equipment:**

**Tool Kit, 5180-00-177-7033**

Shop Equipment, 4910-00-754-0654

**Equipment Condition:**

Reference	Condition Description
Paragraph 4-25	Spark Plug Disconnected
Paragraph 4-33	Battery Removed
Paragraph 4-22	Air Cleaner Removed

**B. REMOVAL**

- (1) Remove starter pulley case (1) by removing five bolts (2).
- (2) Disconnect two piggyback wires (3) from starter solenoid (4).
- (3) Remove insulator cap (5), nut (6), lockwasher (7), and power cable (8) from solenoid terminal.
- (4) Remove two bolts (9) from starter driver side housing (10). Remove starter (11).

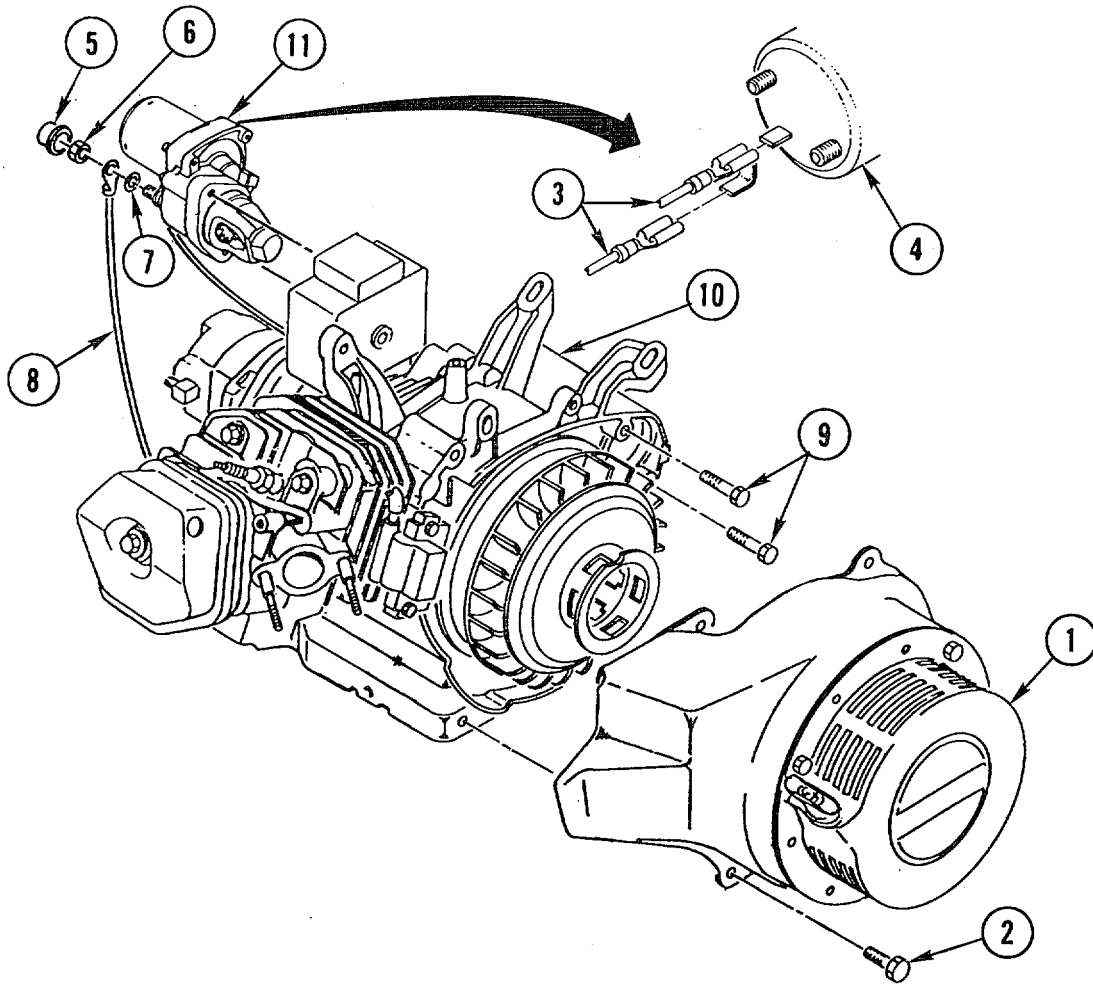

**C. INSTALLATION**

- (1) Insert starter (11) in engine and install two bolts (9) in starter driver side housing (10).
- (2) Align starter pulley case (1) on engine and install five bolts (2).
- (3) Connect two piggyback wires (3) to starter solenoid (4).
- (4) Install power cable (8), lockwasher (7), nut (6), and insulator cap (5) on starter solenoid (4).

**5-7. STARTER MOTOR REPAIR**

This task covers: Disassembly    Assembly

---

**A. INITIAL SETUP**

**Tools and Special Equipment:**

Tool Kit, 5180-00-177-7033  
 Multimeter, AN/URM 105  
 Snap Ring Pliers

**Equipment Condition :**

Reference	Condition Description
Paragraph 5-6	Starter Motor Removed

**Materials/Parts:**

Brush (4)                      Appendix E, Item 2

---

**B. DISASSEMBLY**

- (1) Remove three screws (1) from commutator housing (2).
- (2) Remove commutator housing (2) from driver side housing (3).
- (3) Remove commutator (4) by removing snap ring (5) to expose brush holder (6).
- (4) Use multimeter to check for continuity between all brushes (7, 8, 9, and 10) as follows:

**NOTE**

Continuity check determines serviceability of center bracket. If positive brushes have no continuity, starter motor must be replaced.

- (a) Check continuity between positive brush (9) and positive brush (10). There should be continuity. If there is no continuity, replace starter motor (para 5-6).
- (b) Check continuity between negative brush (7) and positive brushes (9 and 10). There should be no continuity. If there is continuity, replace starter motor (para 5-6).
- (c) Check continuity between negative brush (8) and positive brushes (9 and 10). There should be no continuity. If there is continuity, replace starter motor (para 5-6).
- (5) Remove two negative brushes (7 and 8) with springs and brush holder (6) by removing two screws (11). Discard brushes.
- (6) Remove insulator (12) and two positive brushes (9 and 10) by removing two screws (13). Discard brushes.



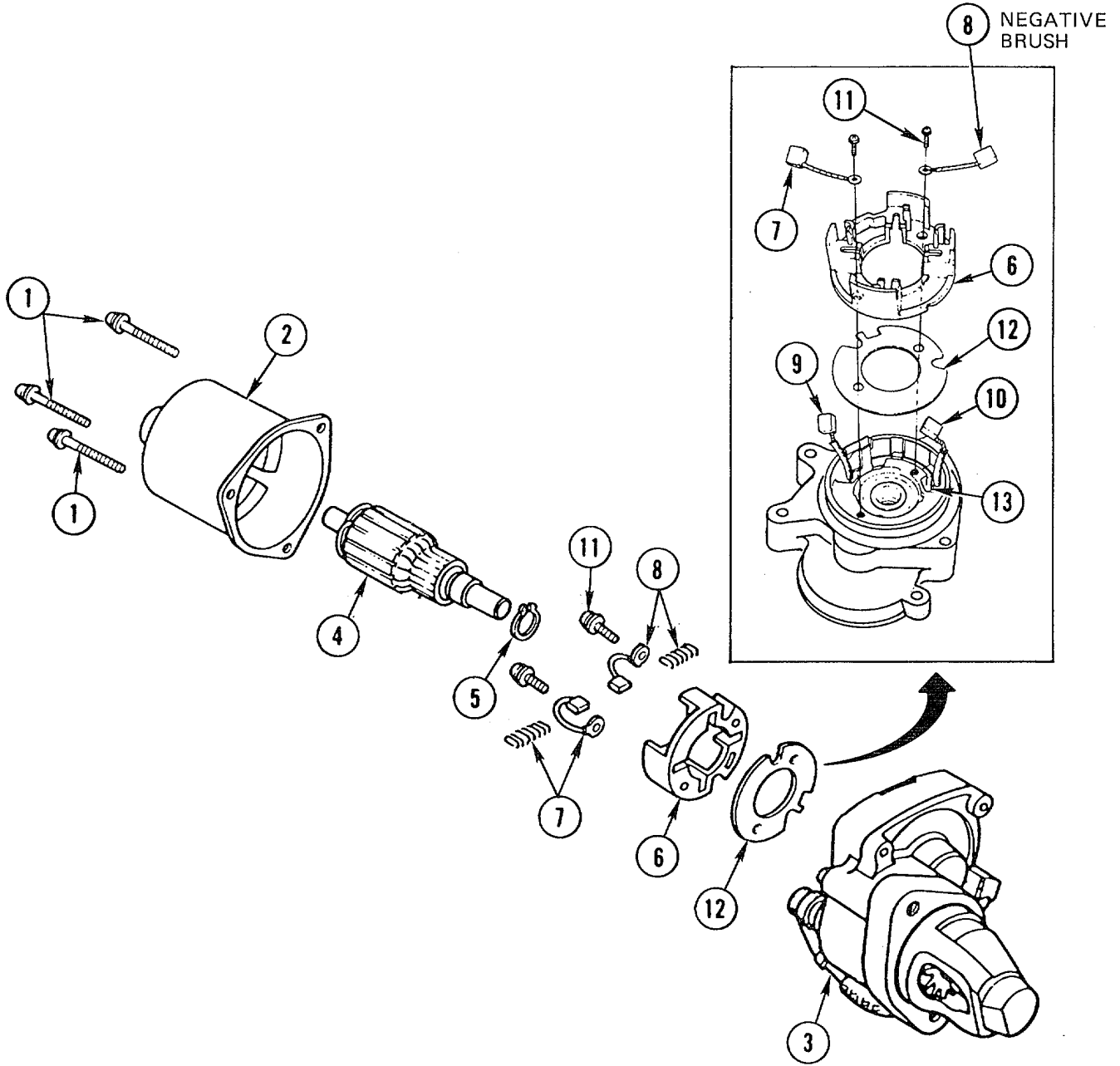

**STARTER MOTOR REPAIR (CONT)**

**C. ASSEMBLY**

- (1) Install two new positive brushes and springs (1 and 2) and insulator (3) in center bracket of driver side housing (4). Secure with two screws (5).
- (2) Install two new negative brushes and springs (6 and 7) in brush holder (8) and secure with two screws (9).
- (3) Replace brush holder (8) into center bracket of driver side housing (4).
- (4) Pushing brushes (1, 2, 6, and 7) apart so brushes do not interfere, install commutator (10) into center bracket of driver side housing (4). Secure with snap ring (11).
- (5) Align commutator housing (12) and driver side housing (4) and install three screws (13).

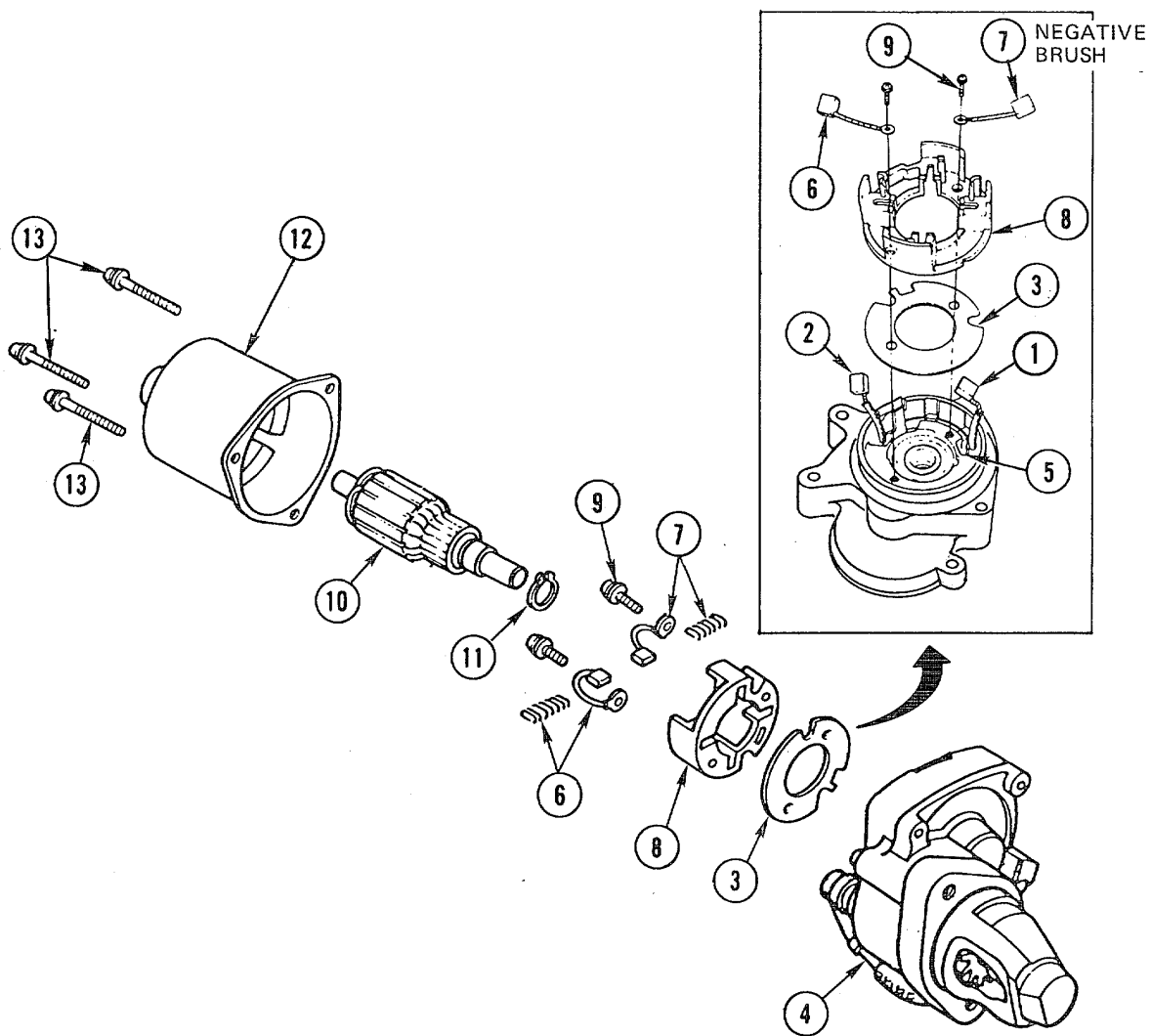

**5-8. ENGINE AND PUMP ASSEMBLY HYDRAULIC PUMP ASSEMBLY REPAIR**

This task covers: Disassembly Inspection Repair Assembly

---

**A. INITIAL SETUP**

**Tools and Special Equipment:**

Tool Kit, 5180-00-177-7033  
 Shop Equipment, 4910-00-754-0654  
 Plastic Hammer/Mallet

**General Safety Instructions:**

**WARNING**

Death or serious injury could result by repeated and/or prolonged breathing and/or skin contact of drycleaning solvent (P-D-680). Use in a well-ventilated area. Do not use near open flame or in excessive heat. The flash point of this solvent is 100°F-138OF (38°C-59°C).

**Materials/Parts:**

Kit, Parts Repair	Appendix E, Item 25
Solvent, Drycleaning, P-D-680	Appendix E, Item 59
File, Emery Stone	Appendix E, Item 7
Fluid, Hydraulic	Appendix E, Item 10

**Equipment Condition :**

<b>Reference</b>	<b>Condition Description</b>
Paragraph 4-27	Hydraulic Pump Removed

---

**ENGINE AND PUMP ASSEMBLY HYDRAULIC PUMP ASSEMBLY REPAIR (CONT)**

---

**B. DISASSEMBLY****WARNING**

Death or serious injury could result by repeated and/or prolonged breathing and/or skin contact of drycleaning solvent (P-D-680). Use in a well-ventilated area. Do not use near open flame or in excessive heat. The flash point of this solvent is 100°F-138°F (38°C-59°C).

**CAUTION**

Keep work area as clean as possible to prevent contamination of pump internal parts. Dirt or grit will damage machined surfaces, resulting in leaks or premature pump failure.

- (1) Remove drive key from pump shaft.
- (2) Clean outside of pump assembly (1) with drycleaning solvent (item 59, Appendix E) and dry thoroughly.
- (3) Place pump assembly (1) in vise, shaft down.
- (4) Remove eight bolts (2).
- (5) Scribe matchmarks at junction of front plate (3), body (4), and back plate (5) to make sure parts will be installed in same location and orientation that they are removed.
- (6) Remove pump assembly (1) from vise.
- (7) Hold pump assembly (1) in hands and pump shaft (6) against wooden block to separate front plate (3) from back plate (5). Body (4) will remain with either front plate (3) or back plate (5).
- (8) Separate sections by tapping protruding end of pump shaft (6) with plastic hammer.
- (9) Remove diaphragm (7) from front plate (3). Discard diaphragm seal.
- (10) Lift backup gasket (8) from front plate (3). Discard backup gasket.
- (11) Lift protector gasket (9) from front plate (3). Discard protector gasket.
- (12) Lift diaphragm V seal (10) from front plate (3). Discard diaphragm V seal.
- (13) Lift two springs (11) and two steel check balls (12) from front plate (3). Discard two springs and two steel check balls.

**NOTE**

Note direction of lip to aid in installation of new lip seal.

(14) Remove lip seal (13) from front plate (3). Discard lip seal.

(15) Separate body (4) from back plate (5) and remove and discard O-ring (14).

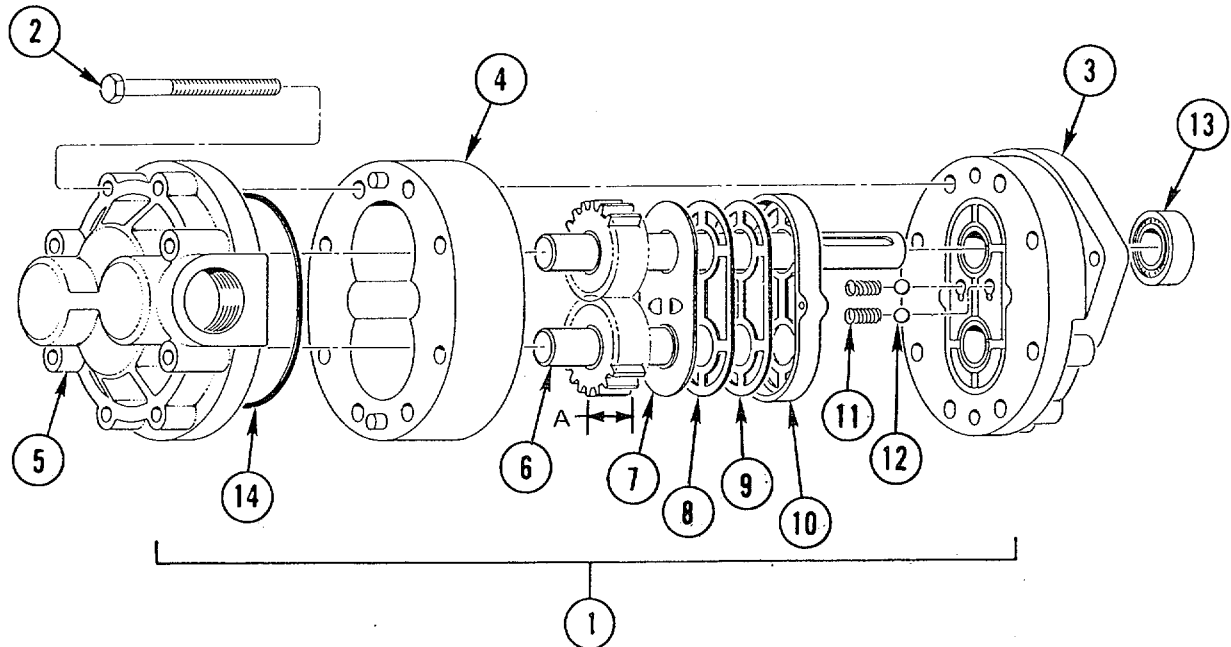

**C. INSPECTION**

- (1) Inspect drive gear shaft for broken keyway.
- (2) Measure diameter of shafts. If shafts measure less than 0.5605 in. (1.4237 cm), replace pump (para 4-27).
- (3) Measure dimension A for scoring and wear. If wear is more than 0.535 in., replace pump (para 4-27).
- (4) Measure inside dimension of bearings in front (3) and back (5) plates. If measurement exceeds 0.5655 in. (1.4364 cm), replace pump (para 4-27).
- (5) Inspect face of back plate (5) for scoring. If wear exceeds 0.0015 in. (0.0038 cm), replace pump (para 4-27).
- (6) Measure inside dimension of gear pockets. If measurement exceeds 1.404 in. (3.566 cm), replace pump (para 4-27).

---

**ENGINE AND PUMP ASSEMBLY HYDRAULIC PUMP ASSEMBLY REPAIR (CONT)**

---

**D. REPAIR**

- (1) Using emery stone file (item 7, Appendix E), remove burrs or sharp edges from shaft end, keyway, gear teeth, and body.
- (2) Other repair is limited to removal and replacement of parts in parts repair kit.

**E. ASSEMBLY**

---

**WARNING**

---

Death or serious injury could result by repeated and/or prolonged breathing and/or skin contact of drycleaning solvent (P-D-680). Use in a well-ventilated area. Do not use near open flame or in excessive heat. The flash point of this solvent is 100°F-138°F (38°C-59°C).

**NOTE**

All parts in parts repair kit should be used to replace parts in pump.

- (1) Thoroughly clean all parts of hydraulic pump with drycleaning solvent (item 59, Appendix E) and dry thoroughly.
- (2) Install new lip seal (1) in front plate (2) in same direction noted during removal.
- (3) Seat lip seal (1) by tapping with plastic hammer.
- (4) Install two new steel check balls (3) and two new springs (4) in front plate (2).
- (5) Place new diaphragm V seal (5) over groove in front plate (2) with lips of V section down and carefully work edges of seal (5) into groove. Press down on seal web until seal is bottomed out.
- (6) Place new protector gasket (6) in grooves over diaphragm V seal (5) and carefully work gasket down into grooves until bottomed out.
- (7) Place new backup gasket (7) over protector gasket (6) and press firmly in place.
- (8) Install new diaphragm (8) with bronze face up. Make sure entire diaphragm fits inside raised rim of diaphragm V seal (5).
- (9) Lubricate remaining pump parts with hydraulic fluid (item 10, Appendix E).
- (10) Slip drive gear assemblies (9) into front plate (2) bearings.
- (11) Align matchmarks and slip body (10) over drive gear assemblies onto front plate (2).

- (12) Install new O-ring (11) on back plate (12).
- (13) Align matchmarks and slide back plate (12) over gear shafts until dowel pins are engaged.
- (14) Install eight bolts (13). Tighten bolts evenly to 35-40 lb-ft (47-54 N.m).
- (15) Rotate shaft (9) by hand or with pliers. Shaft will have small amount of drag but should turn freely after short period of use.
- (16) Install drive key in pump shaft.

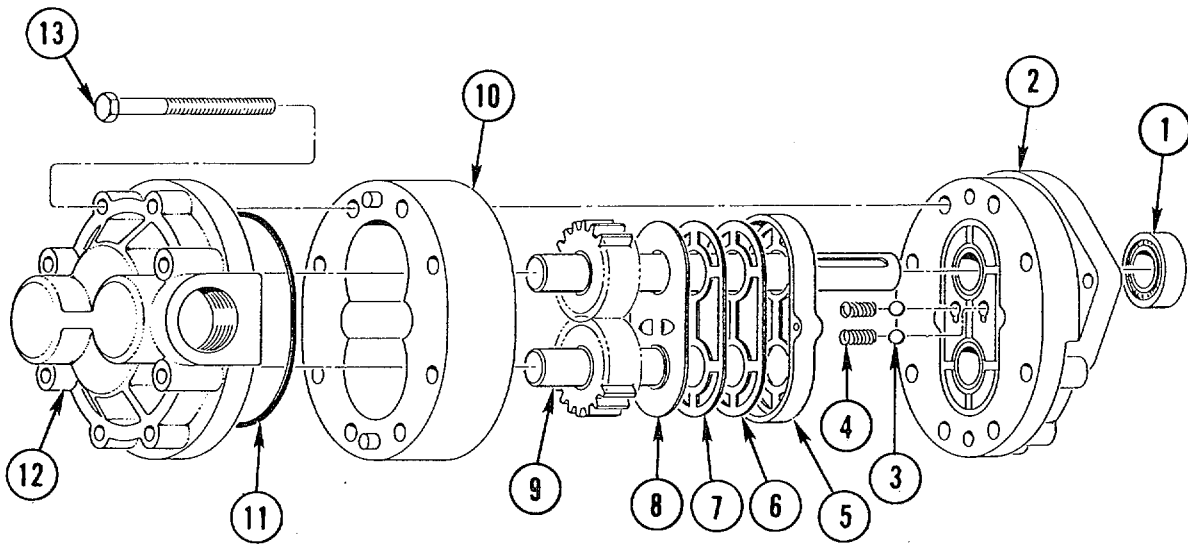

**5-9. SECONDARY HYDRAULIC MANIFOLD ASSEMBLY REPAIR**

This task covers: Disassembly Cleaning Solenoid Repair Flow Regulator Repair Assembly

---

**A. INITIAL SETUP**

**Tools and Special Equipment:**

Tool Kit, 5180-00-177-7033

**Materials/Parts:**

O-Ring	Appendix E, Item 41
Kit, Parts Repair	Appendix E, Item 29
Kit, Parts Repair	Appendix E, Item 28
Solvent, Drycleaning, P-D-680	Appendix E, Item 59
Sealant, Thread	Appendix E, Item 55

**Equipment Condition:**

<b>Reference</b>	<b>Condition Description</b>
Paragraph 4-32	Secondary Hydraulic Manifold Removed

**General Safety Instructions:**

**WARNING**

Death or serious injury could result by repeated and/or prolonged breathing and/or skin contact of drycleaning solvent (P-D-680). Use in a well-ventilated area. Do not use near open flame or in excessive heat. The flash point of this solvent is 100°F-183°F (38°C-59°C).

Compressed air used for cleaning and drying purposes shall not exceed 30 psi. Use only with effective chip guarding and personal protective equipment (goggles/shield, gloves, etc.). Flying debris could cause personal injury debris could cause



**B. DISASSEMBLY**

- (1) Remove flow regulator (1).
- (2) Remove pressure gage (2).
- (3) Remove 12 VDC coil (3) by removing nut (4).
- (4) Remove check valve (5).
- (5) Remove solenoid (6).

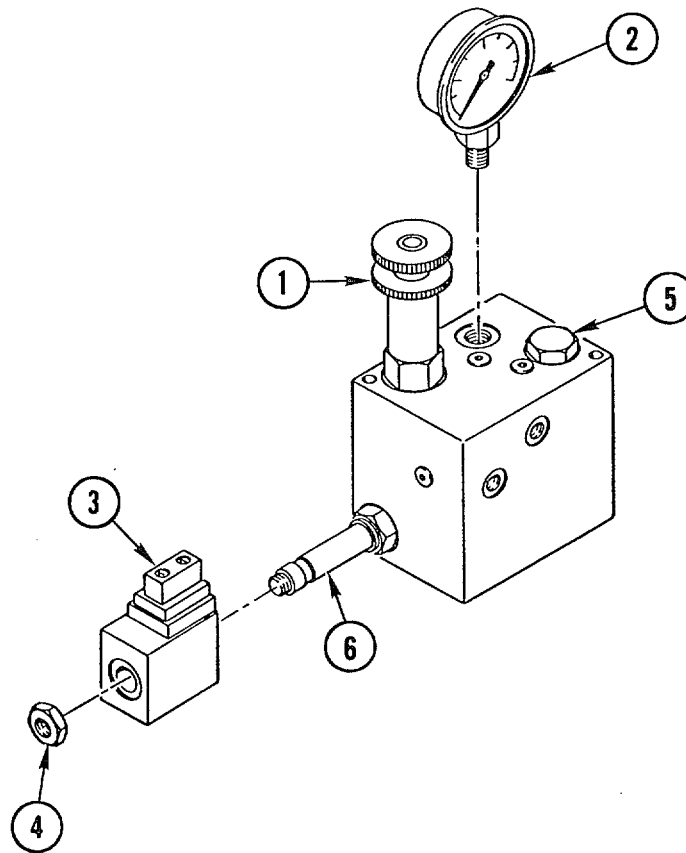

---

**SECONDARY HYDRAULIC MANIFOLD ASSEMBLY REPAIR (CONT)**

---

**C. CLEANING**

---

**WARNING**

---

Death or serious injury could result by repeated and/or prolonged breathing and/or skin contact of drycleaning solvent (P-D-680). Use in a well-ventilated area. Do not use near open flame or in excessive heat. The flash point of this solvent is 100°F-183°F (38°C-59°C).

- (1) Flush out manifold with drycleaning solvent (item 59, Appendix E).

---

**WARNING**

---

Compressed air used for cleaning and drying purposes shall not exceed 30 psi. Use only with effective chip guarding and personal protective equipment (goggles/shield, gloves, etc.). Flying debris could cause personal injury.

- (2) Dry manifold with low-pressure air.
- (3) Clean valves with drycleaning solvent (item 59, Appendix E).

**D. SOLENOID REPAIR**

**NOTE**

Note order of removal to aid in assembly.

- (1) Remove and discard spacers and O-rings (1) from solenoid (2).
- (2) Install new O-rings and spacers (1) from parts repair kit on solenoid (2) in order noted during disassembly.

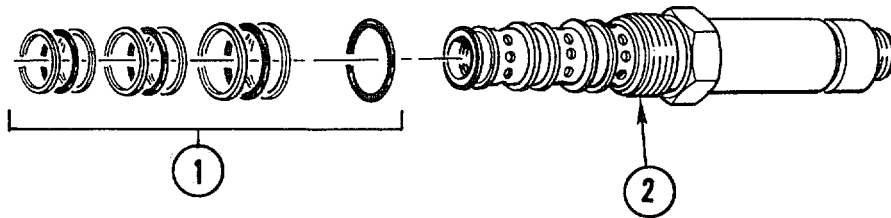

**E. FLOW REGULATOR REPAIR**

**NOTE**

Note order of removal to aid in assembly.

- (1) Remove and discard spacers and O-rings (1) from flow regulator (2).
- (2) Install new O-rings and spacers (1) from parts repair kit on flow regulator (2) in order noted during disassembly.

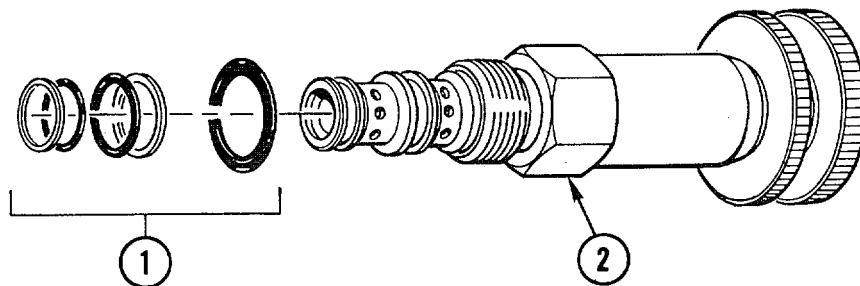

---

**SECONDARY HYDRAULIC MANIFOLD ASSEMBLY REPAIR (CONT)**

---

**F. ASSEMBLY**

- (1) Apply thread sealant (item 55, Appendix E) to pressure gage threads and install pressure gage (1). Wipe off excess sealant.
- (2) Install flow regulator (2).
- (3) Install solenoid (3).
- (4) Install check valve (4).
- (5) Install 12 VDC coil (5) and secure with nut (6).

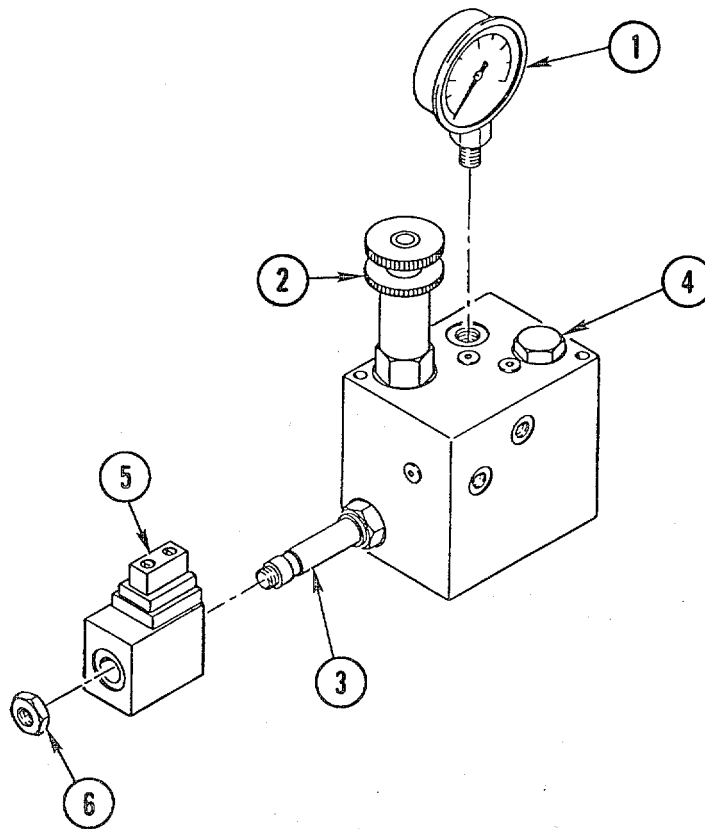

**5-10. PRIMARY HYDRAULIC MANIFOLD ASSEMBLY REPAIR**

This task covers: Disassembly Cleaning Relief Valve Repair Solenoid Repair  
 Flow Regulator Repair Needle Valve Repair Assembly

**A. INITIAL SETUP**

**Tools and Special Equipment:**

Tool Kit, 5180-00-177-7033

**Materials/Parts:**

- Kit, Parts Repair Appendix E, Item 31
- Kit, Parts Repair Appendix E, Item 30
- Kit, Parts Repair Appendix E, Item 29
- Kit, Parts Repair Appendix E, Item 32
- O-Ring Appendix E, Item 43
- Solvent, Drycleaning, Appendix E, Item 59  
P-D-680
- Sealant, Thread Appendix E, Item 55

**Equipment Condition :**

Reference	Condition Description
Paragraph 4-36	Primary Hydraulic Manifold Removed

**General Safety Instructions:**

**WARNING**

Death or serious injury could result by repeated and/or prolonged breathing and/or skin contact of drycleaning and/or skin contact of drycleaning solvent (P-D-680). Use in a well-ventilated area. Do not use near open flame or in excessive heat. The flash point of this solvent is 100°F-183°F (38°C-59°C).

Compressed air used for cleaning and drying purposes shall not exceed 30 psi. Use only with effective chip guarding and personal protective equipment (goggles/shield, gloves, etc.). Flying debris could cause personal injury.

---

**PRIMARY HYDRAULIC MANIFOLD ASSEMBLY REPAIR (CONT)**

---

**B. DISASSEMBLY**

- (1) Remove pressure gage (1).
- (2) Remove and discard O-ring (2).
- (3) Remove nut (3) and solenoid coil (4).
- (4) Remove solenoid (5).
- (5) Remove relief valve (6).
- (6) Remove needle valve (7).
- (7) Remove flow regulator (8).

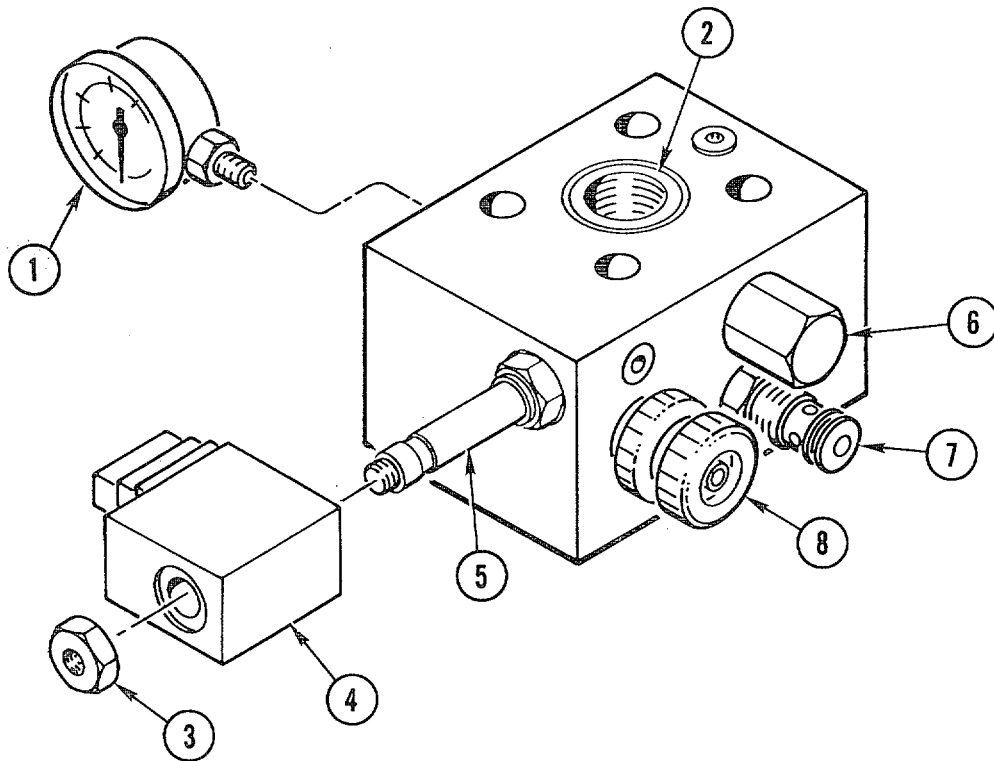

**C. CLEANING****WARNING**

Death or serious injury could result by repeated and/or prolonged breathing and/or skin contact of drycleaning solvent (P-D-680). Use in a well-ventilated area. Do not use near open flame or in excessive heat. The flash point of this solvent is 100°F-183°F (38°C-590C).

- (1) Flush out manifold with drycleaning solvent (item 59, Appendix E).

**WARNING**

Compressed air used for cleaning and drying purposes shall not exceed 30 psi. Use only with effective chip guarding and personal protective equipment (goggles/shield, gloves, etc.). Flying debris could cause personal injury.

- (2) Dry manifold with low-pressure air.
- (3) Clean valves with drycleaning solvent (item 59, Appendix E).

**D. RELIEF VALVE REPAIR****NOTE**

Note order of removal to aid in assembly.

- (1) Remove and discard spacer and O-rings (1) from relief valve (2).
- (2) Install new O-rings and spacer (1) from parts repair kit on relief valve (2) in order noted during disassembly.

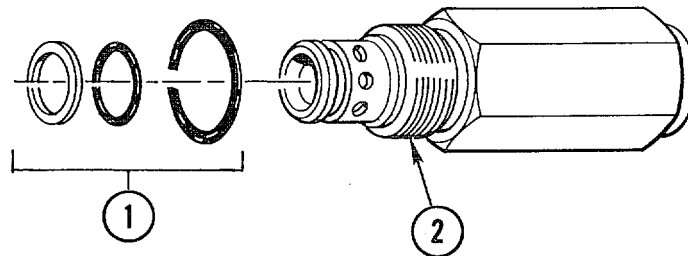

**PRIMARY HYDRAULIC MANIFOLD ASSEMBLY REPAIR (CONT)**

**E. SOLENOID REPAIR**

**NOTE**

Note order of removal to aid in assembly.

- (1) Remove and discard spacer and O-rings (1) from solenoid (2).
- (2) Install new O-rings and spacer (1) from parts repair kit on solenoid (2) in order noted during disassembly.

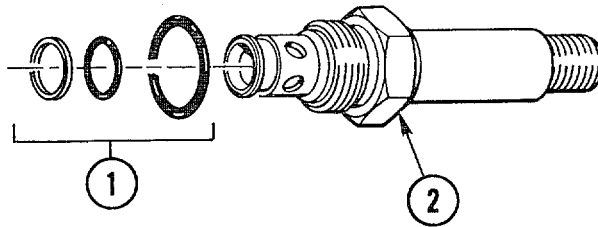

**F. FLOW REGULATOR REPAIR**

**NOTE**

Note order of removal to aid in assembly.

- (1) Remove and discard spacer and O-rings (1) from flow regulator (2).
- (2) Install new O-rings and spacer (1) from parts repair kit on flow regulator (2) in order noted during disassembly.

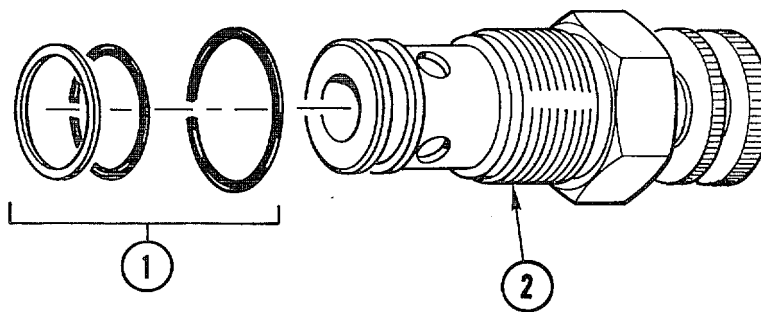



**G. NEEDLE VALVE REPAIR****NOTE**

Note order of removal to aid in assembly.

- (1) Remove and discard spacers and O-rings (1) from needle valve (2).
- (2) Install new spacers and O-rings (1) from parts repair kit on needle valve (2) in order noted during disassembly.

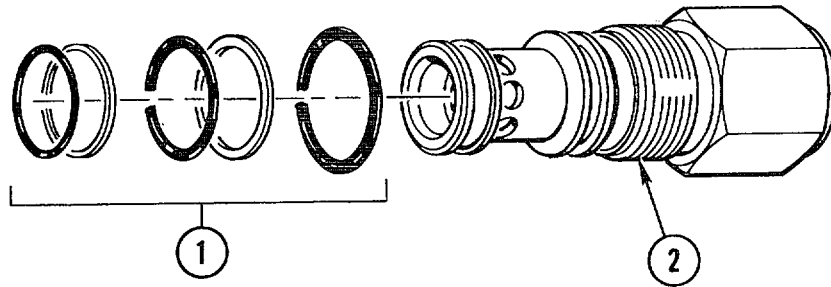

---

**PRIMARY HYDRAULIC MANIFOLD ASSEMBLY REPAIR (CONT)**

---

**H. ASSEMBLY**

- (1) Install flow regulator (1).
- (2) Install needle valve (2).
- (3) Install relief valve (3).
- (4) Install solenoid (4).
- (4) Install solenoid coil (5) and secure with nut (6).
- (5) Install new O-ring (7).
- (6) Apply thread sealant (item 55, Appendix E) to pressure gage threads and install pressure gage (8). Wipe off excess sealant.

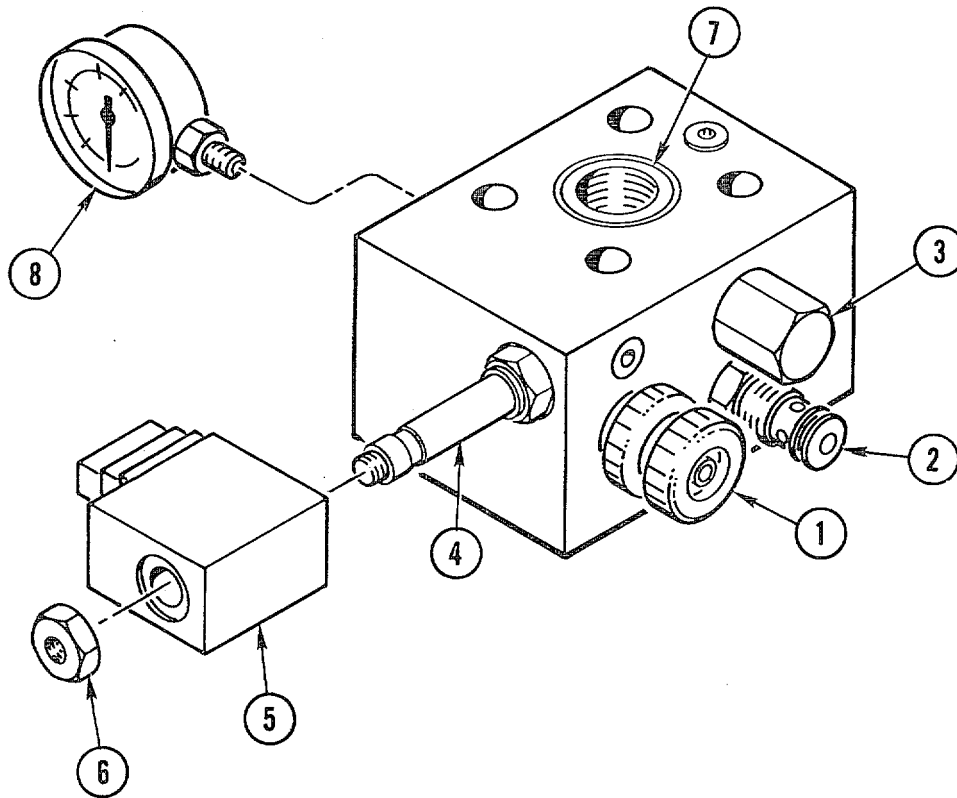

**5-11. HAND CONTROL ASSEMBLY REPAIR**

---

This task covers:      Disassembly      Assembly

---

**A. INITIAL SETUP**

**Tools and Special Equipment:**

Tool Kit, 5180-00-177-7033  
 Soldering Iron  
 Solder Sucker  
 Heat Gun

**Equipment Condition:**

<b>Reference</b>	<b>Condition Description</b>
Paragraph 4-38	Hand Control Assembly Disconnected from Electrical-Safety Cable

**Materials/Parts:**

Tubing, Heat Shrink	Appendix E, Item 63
Wick, Solder	Appendix E, Item 64

---

**HAND CONTROL ASSEMBLY REPAIR (CONT)**

---

**B. DISASSEMBLY****NOTE**

Tag all electrical leads prior to removal to aid in installation.

- (1) Open hand control assembly (1) by removing two screws (2) and pulling back hand control assembly cover (3).
- (2) Remove three nuts (4) and three washers (5) from three toggle switches (6).
- (3) Remove nut (7) and washer (8) from pushbutton switch (9).
- (4) Remove heat shrink tubing from three toggle switches (6), pushbutton switch (9), and three LED indicators (10).
- (5) Remove three toggle switches (6) and pushbutton switch (9) by removing solder from switch solder connections.
- (6) Remove three LED indicators (10) by removing three plastic nuts (11) on outside of hand control assembly cover (3) and removing solder from solder connections.
- (7) Remove connector (12) by removing four screws (13).
- (8) Remove heat shrink tubing from connector (12) and remove solder from connector (12) at solder connection.

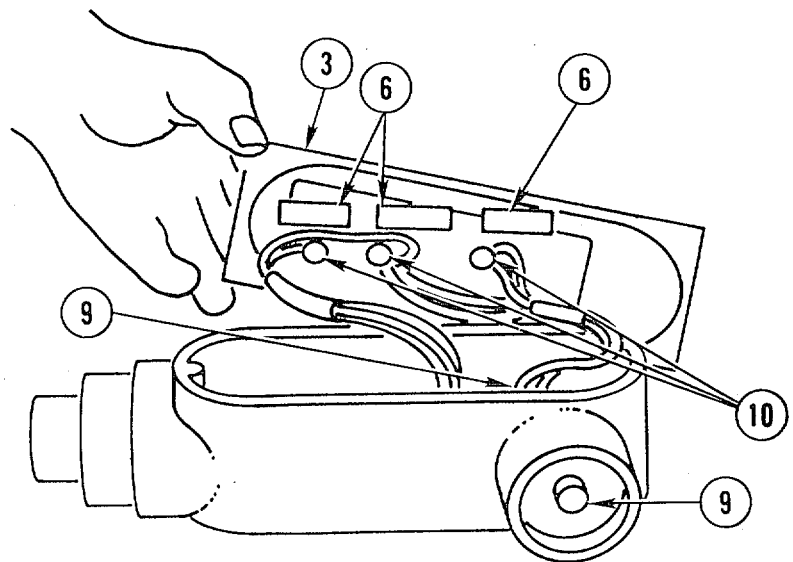
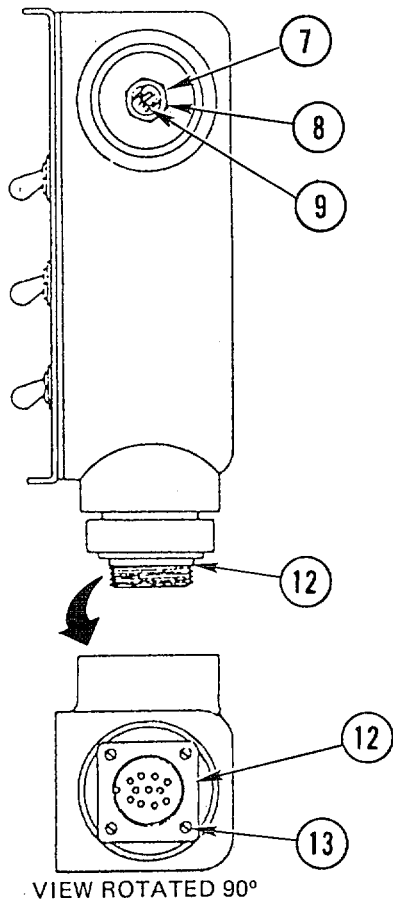
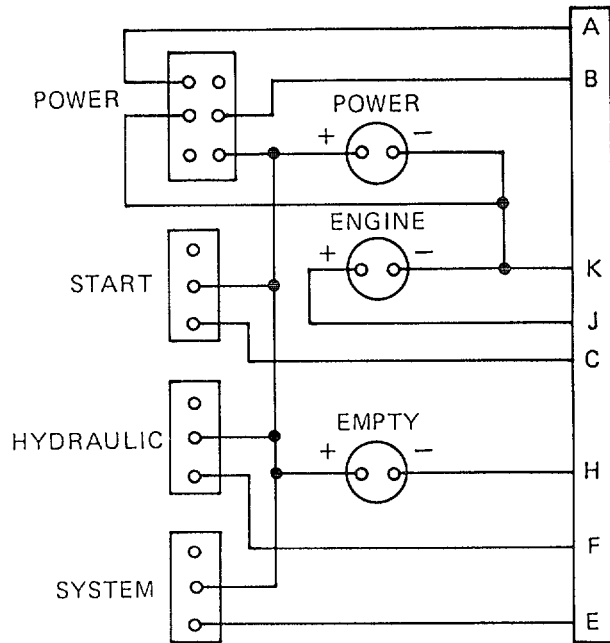
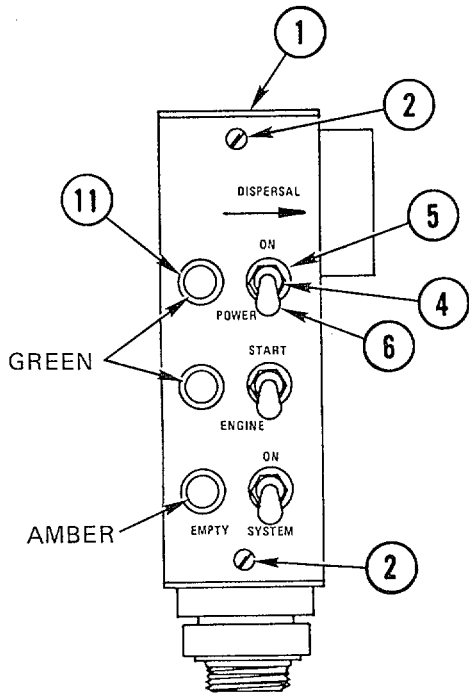

---

**HAND CONTROL ASSEMBLY REPAIR (CONT)**

---

**C. ASSEMBLY**

- (1) Insert pushbutton switch (1) through proper opening in hand control assembly (2) and secure by hand-threading nut (3) with washer (4).
- (2) Hand-thread three nuts (5) and three washers (6) to secure three toggle switches (7).
- (3) Secure three LED indicators (8) with three plastic nuts (9). Tighten all nuts.
- (4) Place 1/2-in. heat shrink tubing (item 63, Appendix E) on each wire and apply flux to solder connections before soldering.
- (5) Solder wires to connector (10).
- (6) Slide heat shrink tubing over each solder connection and apply heat with heat gun.
- (7) Secure connector (10) by installing four screws (11).
- (8) Solder wires to toggle switches (7) and pushbutton switch (1).
- (9) Slide heat shrink tubing over each solder connection and apply heat with heat gun.
- (10) Solder wires to LED indicators (8).
- (11) Slide heat shrink tubing over each solder connection and apply heat with heat gun.
- (12) Secure hand control assembly cover (12) by installing two screws (13).
- (13) Install hand control assembly cover (12) with gasket making sure three toggle switches (7) and three LED indicators (8) are inserted through proper openings.

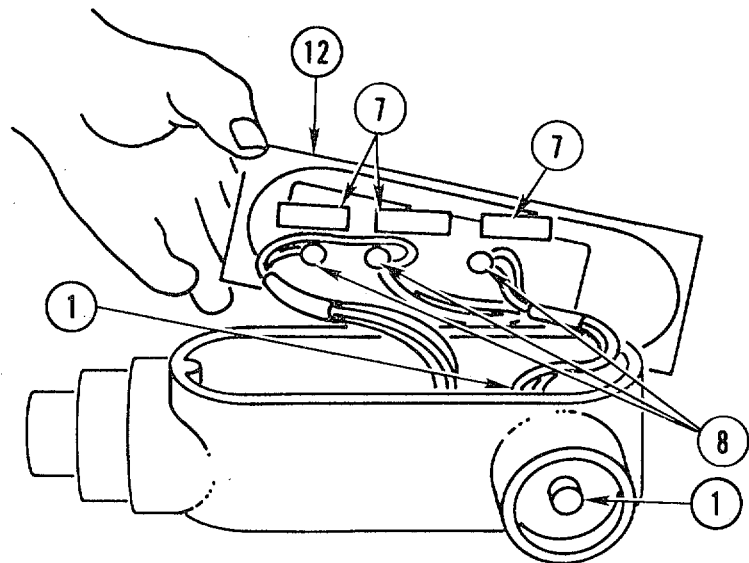
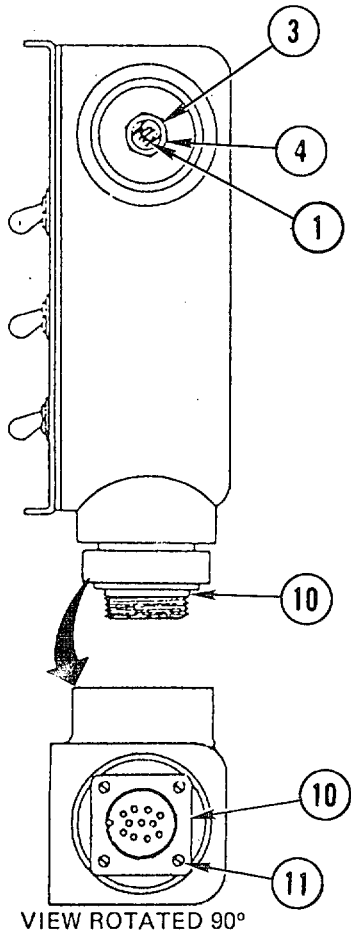
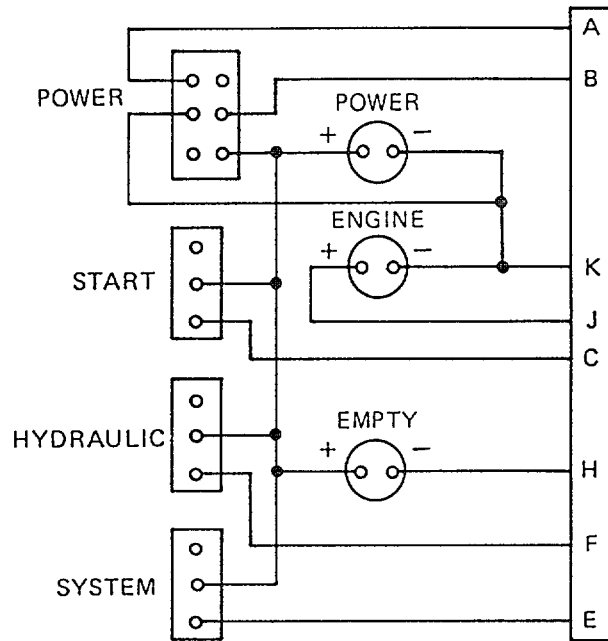
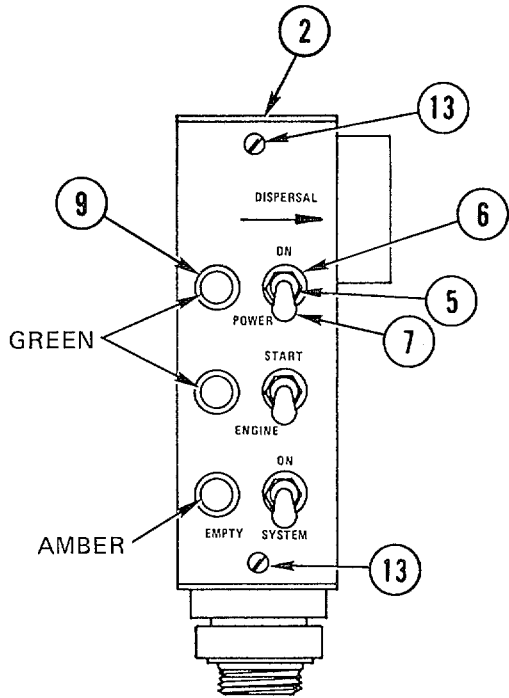

**5-12. PUMP AND CROSSTUBE ASSEMBLY CHEMICAL PUMP REPAIR**

---

This task covers:      Disassembly      Assembly

---

**A. INITIAL SETUP**

**Tools and Special Equipment:**

Tool Kit, 5180-00-177-7033  
 Snap Ring Pliers

**Equipment Condition:**

Reference	Condition Description
Paragraph 4-43	Chemical Pump Removed from Pump and Crosstube Assembly
Paragraph 4-42	Chemical Pump Separated from Motor

**Materials/Parts:**

Kit, Seal      Appendix E, Item 33  
 Loctite      Appendix E, Item 34

---

**B. DISASSEMBLY**

**CAUTION**

Keep work area as clean as possible to prevent contamination of pump internal parts. Dirt or grit will damage machined surfaces, resulting in leaks or premature pump failure.

- (1) Remove eight bolts (1) and eight washers (2) that secure face plate (3) to volute (4). Discard washers.
- (2) Remove face plate (3) and gasket (5). Discard gasket.
- (3) Remove eight bolts (6) and eight washers (7) that secure pump housing (8) to volute (4). Discard washers. Separate volute (4) from housing (8). Remove and discard gasket (9).
- (4) Remove jam nut (10) from impeller shaft (11).
- (5) Unscrew and remove impeller (12).
- (6) Remove seal assembly (13).
- (7) Remove snap ring (14) and press impeller shaft (11) from housing (8).



**NOTE**

Bearing and shaft removes as an assembly.

- (8) Remove snap ring (15) from impeller shaft (11).
- (9) Press bearing (16) off impeller shaft (11).

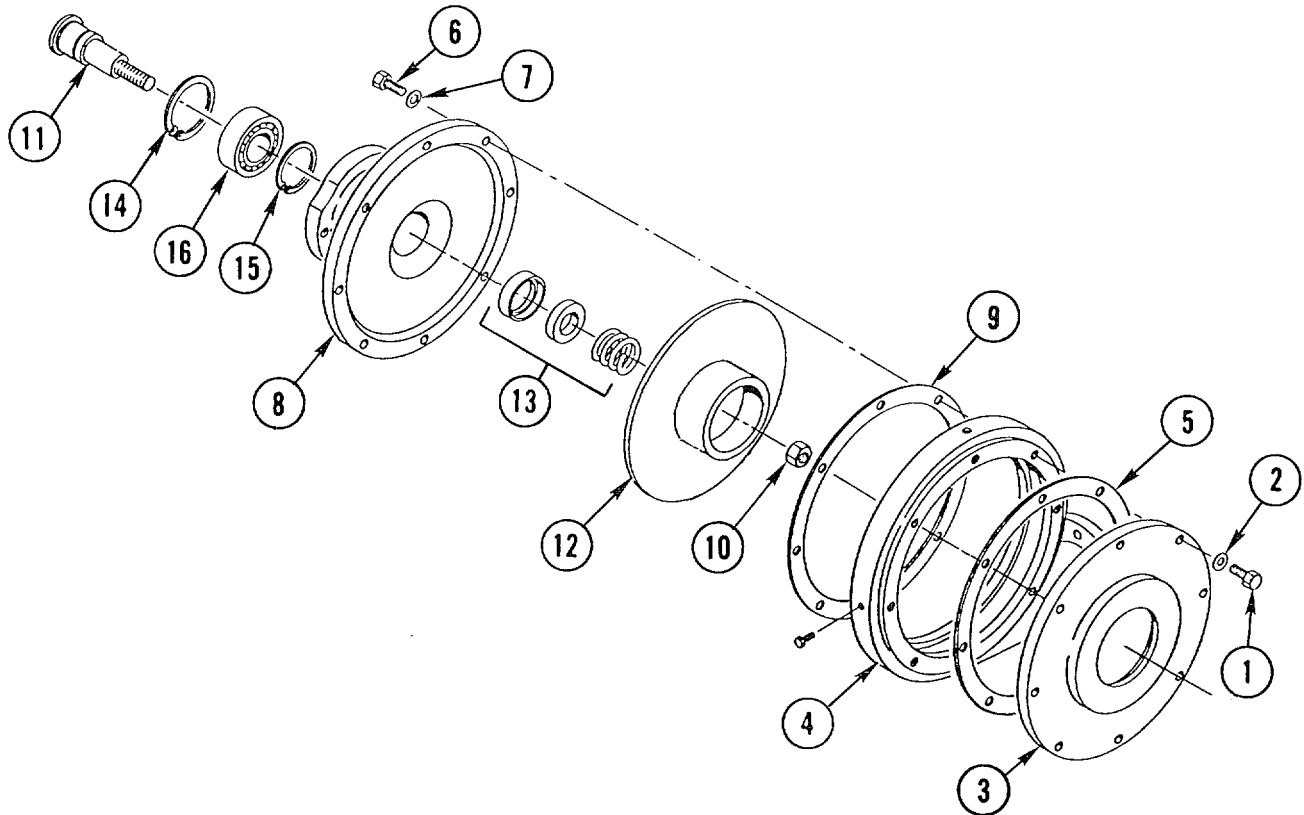

---

**PUMP AND CROSSTUBE ASSEMBLY CHEMICAL PUMP REPAIR (CONT)**

---

**C. ASSEMBLY**

- (1) Install new bearing (1) on impeller shaft (2) and secure with snap ring (3).
- (2) Install impeller shaft (2) and press in pump housing (4).
- (3) Install snap ring (5).
- (4) Install new seal assembly (6) onto impeller shaft (2).
- (5) Coat threads of impeller (7) with Loctite (item 34, Appendix E) or equivalent.
- (6) Install impeller (7) and screw onto impeller shaft (2). Secure with jam nut (8).
- (7) Align new gasket (9) and volute (10) on pump housing (4). Install eight new washers (11) and eight bolts (12) and tighten securely.
- (8) Align new gasket (13) and face plate (14) on volute (10). Install eight new washers (15) and eight bolts (16) and tighten securely.

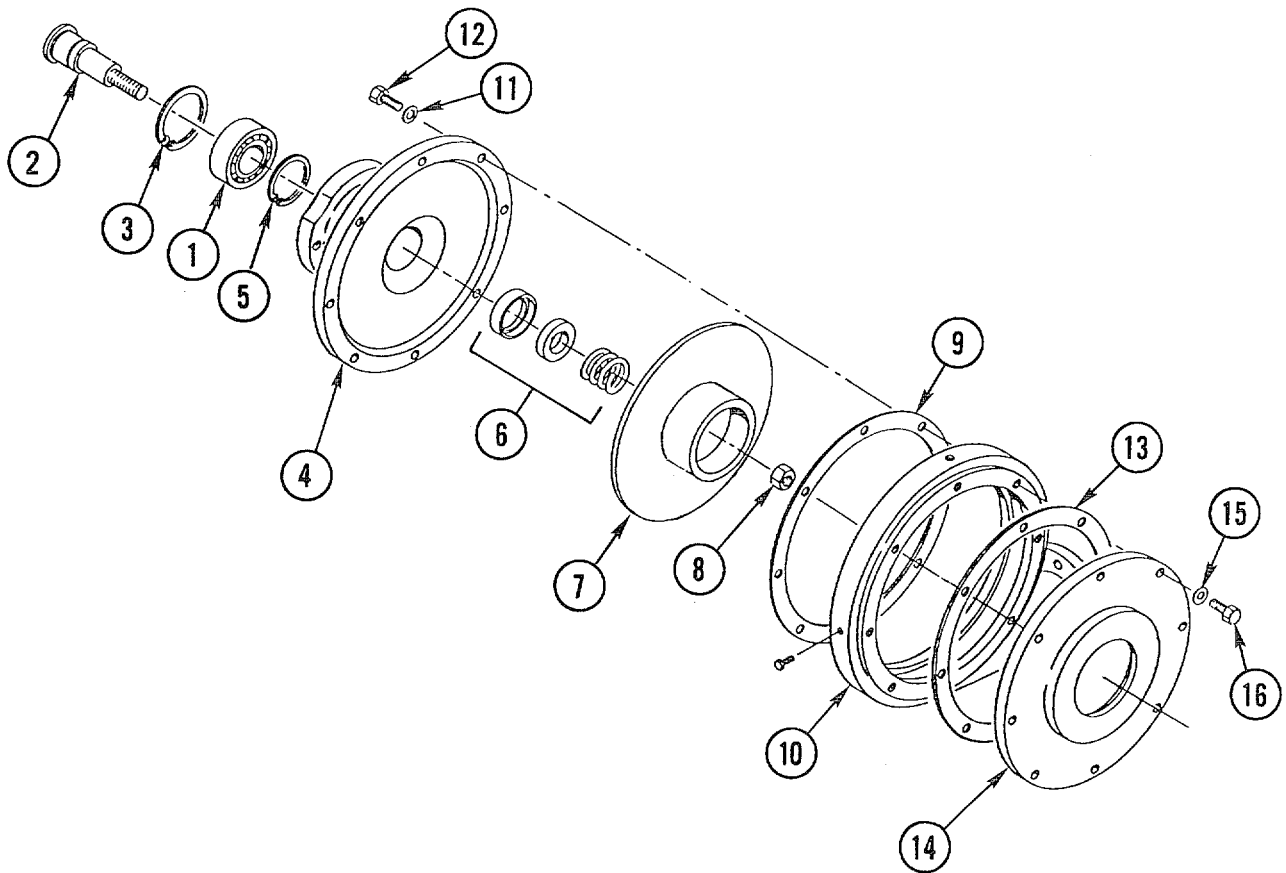

**5-13. HYDRAULIC MOTOR REPAIR**

---

This task covers:	Disassembly	Inspection	Repair	Assembly
-------------------	-------------	------------	--------	----------

---

**A. INITIAL SETUP**

**Tools and Special Equipment:**

Drive Shaft Installation Sleeve  
 Tool Kit, 5180-00-177-7033  
 Shop Equipment, 4910-00-754-0654

**Materials/Parts:**

File, Emery Stone	Appendix E, Item 7
Kit, Parts Repair	Appendix E, Item 26
Oil, SAE 10W-40	Appendix E, Item 40
Lubriplate	Appendix E, Item 35
Solvent, Drycleaning, P-D-680	Appendix E, Item 59

**Equipment Condition:**

Reference	Condition Description
Paragraph 4-44	Motor Removed from Pump and Crosstube Assembly
Paragraph 4-51	Motor Removed from Slinger Assembly

**General Safety Instructions:**

---

**WARNING**

Death or serious injury could result by repeated and/or prolonged breathing and/or skin contact of drycleaning solvent (P-D-680). Use in a well-ventilated area. Do not use near open flame or in excessive heat. The flash point of this solvent is (100°F-138°F (38°C-59°C)).

---

**HYDRAULIC MOTOR REPAIR (CONT)**

---

**B. DISASSEMBLY****WARNING**

Death or serious injury could result by repeated and/or prolonged breathing and/or skin contact of drycleaning solvent P-D-680. Use in a well-ventilated area. Do not use near open flame or in excessive heat. The flash point of this solvent is 100°F-138°F (38°C-59°C).

**NOTE**

Note location and orientation of parts prior to disassembly to aid in assembly. Parts should be installed to same position from which they were removed.

- (1) Clean outside of motor with drycleaning solvent (item 59, Appendix E) and dry thoroughly.
- (2) Scribe matchmarks at junction of body (1) and cover (2) to make sure parts will be installed in same location and orientation that they are removed.
- (3) Remove woodruff key (3) and snap ring (4) from drive gear shaft (5).

**CAUTION**

Use soft-jawed vise and light clamping pressure to avoid damaging motor.

- (4) Secure unit in soft-jawed vise with shaft end down.
- (5) Remove four bolts (6) and four washers (7) that secure pump body (1) to cover (2).
- (6) To separate cover (2) from body (1) hold motor, drive end up, and tap end of drive gear shaft with plastic headed mallet. Do not use metal hammer.

**CAUTION**

Use one hand to support cover from underneath to keep from dropping cover and internal parts when dowels are removed.

**NOTE**

Square cut ring and thrust plate may or may not remain with cover.

Take special note of wear pattern on thrust plate and wear plate. Note that long journal of drive gear is toward drive end of motor.

- (7) If square cut ring (8) and thrust plate (9) remain with body (1), remove square cut ring (8) and lift out thrust plate (9). Discard square cut ring.
- (8) Lift out drive gear shaft (5), drive gear (10), wear plate (11), and pressure loading seal (12). Discard pressure loading seal.

**CAUTION**

Remove shaft seal carefully. Do not damage shaft seal bore or seal leakage will result.

- (9) Remove ball bearings (13).
- (10) Invert motor body with shaft seal (14) up. Remove retainer (15). Remove shaft seal (14) by prying seal out with large screwdriver. Discard shaft seal.

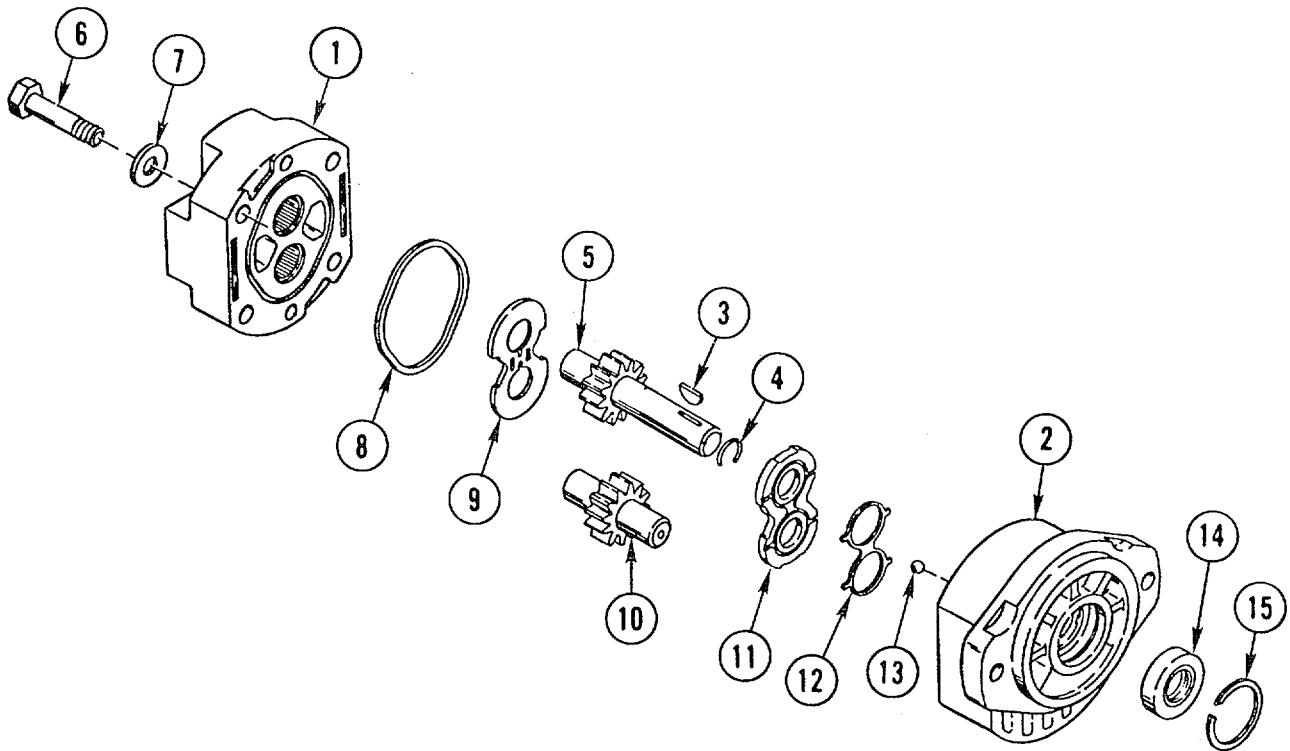

---

**HYDRAULIC MOTOR REPAIR (CONT)**

---

**C. INSPECTION**

- (1) Inspect wear plate and thrust plate for scoring or uneven wear. If scored or worn, replace motor (para 4-44).
- (2) Inspect needle bearings in body and cover. If bearings are skewed, broken, or otherwise damaged, replace motor (para 4-44).
- (3) Inspect gear journals and faces for wear or scoring. If gear journal wear exceeds 0.001 in. (0.00254 cm), replace motor (para 4-44).
- (4) Inspect body for wear or scoring. If gear contact wear on low-pressure (outlet) side exceeds 0.005 in. (0.0127 cm) depth, replace motor (para 4-44).

**D. REPAIR**

- (1) Using emery stone file (item 7, Appendix E), remove burrs or sharp edges from shaft end, keyway, and body.
- (2) Other repair is limited to removal and replacement of parts in parts repair kit.

**E. ASSEMBLY****CAUTION**

Install shaft seal square with face of bore. Do not allow shaft seal to cock during installation or leakage and premature motor failure will result.

**NOTE**

All parts of parts repair kit should be used to replace parts in pump motor.

- (1) Place cover (1), shaft seal (2) bore up, on flat plate in arbor press.
- (2) Press shaft seal (2) below front face of cover (1) 0.155-0.165 in. (0.394-0.419 cm). Pack area between double lip of shaft seal (2) with Lubriplate (item 35, Appendix E) or equivalent.
- (3) Install retainer (3), sharp edge out.
- (4) Invert cover (1) so gear bores are up. Install ball bearing (4). Install new pressure loading seal (5) in seal grooves against bottom of bore surface. Install wear plate (6) in bottom of bore, making sure pressure loading seal (5) is positioned properly in seal grooves and is against bottom of bore surface.
- (5) Lubricate bearings in cover and face of wear plate (6) with SAE 10W-40 oil (item 40, Appendix E).
- (6) Apply Lubriplate (item 35, Appendix E) or equivalent to outer surface of drive shaft installation sleeve.

- (7) Insert sleeve into inside diameter of shaft seal (2) from front of motor until sleeve contacts drive gear bearing. Install drive gear shaft (7). Remove drive shaft installation sleeve.
- (8) Install drive gear shaft (8) with long journal toward front of motor.
- (9) Lubricate rear gear faces and journals with SAE 10W-40 oil (item 40, Appendix E) and install thrust plate (9) with bronze thrust surface contacting gear face.
- (10) Apply Lubriplate (item 35, Appendix E) to body (10) groove and install new square cut ring (11) into groove.

**CAUTION**

Maintain body in vertical position, gear bores up, during cover installation to prevent shifting of thrust plate. Any shift of thrust plate will result in pinching between cover and body when cover bolts are tightened.

- (11) Lubricate cover (1) bearings with SAE 10W-40 oil (item 40, Appendix E). Match matchmarks on cover (1) with matchmarks on body (10) and install cover (1).
- (12) Position motor in arbor press, shaft end down, and press on cover (1) while installing four washers (12) and four bolts (13). If press is not available, install washers (12) and bolts (13) and tighten evenly in cross pattern to avoid pinching parts. When all bolts (13) are installed and cover (1) is tightened down, torque bolts to 34-38 lb-ft (46-51.5 N.m).
- (13) Install snap ring (14) and woodruff key (15) on drive gear shaft (7).
- (14) Using adjustable wrench to turn drive gear shaft (7), verify drive gear shaft (7) turns without evidence of mechanical bind.

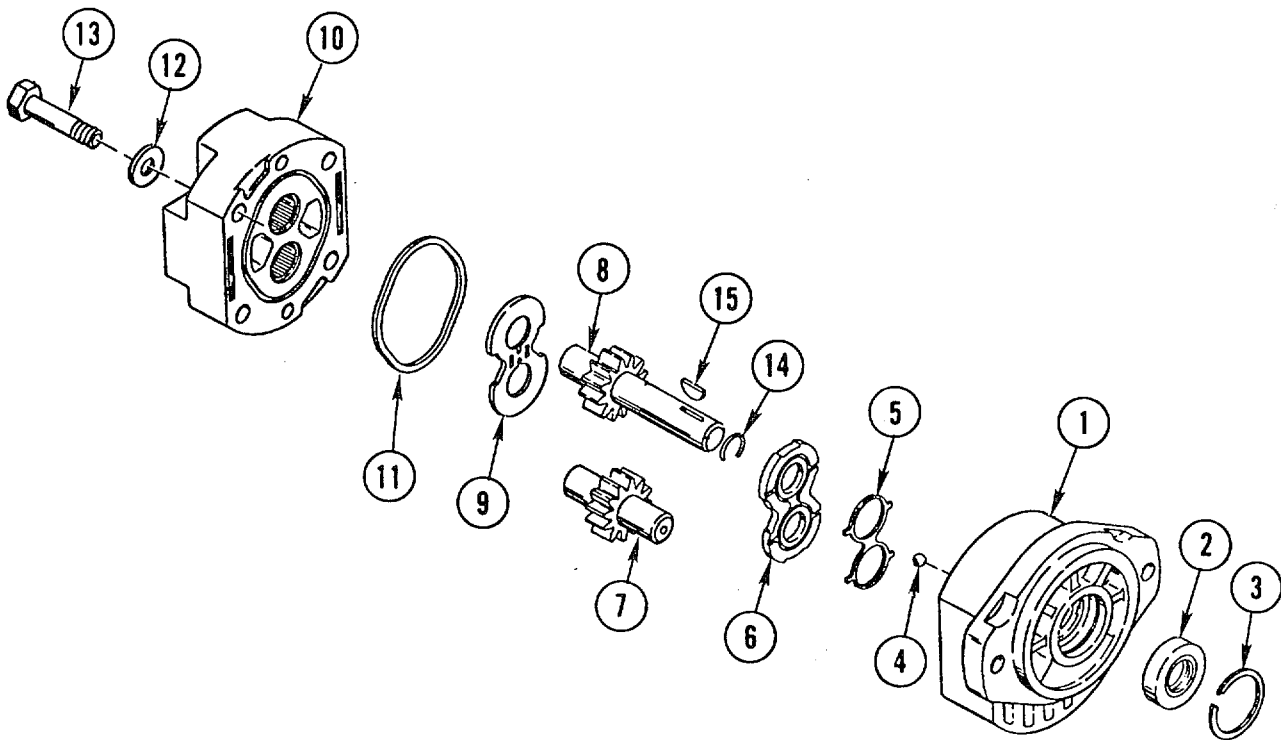

**5-14. PUMP AND CROSSTUBE ASSEMBLY SPRAY SYSTEM CONTROL REPAIR**

---

This task covers:      Disassembly      Assembly

---

**A. INITIAL SETUP**

**Tools and Special Equipment:**

Tool Kit, 5180-00-177-7033

**Equipment Condition:**

**Reference**

Paragraph 4-45

**Condition Description**

Spray System Control  
Removed

**Materials/Parts:**

Kit, Parts Repair

Appendix E, Item 24

---

**B. DISASSEMBLY**

- (1) Remove six screws (1) securing valve body (2) to bracket (3).
- (2) Remove assembly nut (4), end connector (5), O-ring (6), teflon seat (7), ball valve assembly (8), and teflon seat (9). Discard O-ring (6), teflon seat (7), ball valve assembly (8), and teflon seat (9).
- (3) Remove four nuts (10), eight washers (11), and four bolts (12).
- (4) Loosen Allen screws (13) on collar clamp assembly (14) and remove actuator (15).
- (5) Remove collar clamp assembly (14) by pushing turn stem (16) from valve body (2).
- (6) Remove turn stem (16) from valve body (2) and remove and discard O-ring (17).



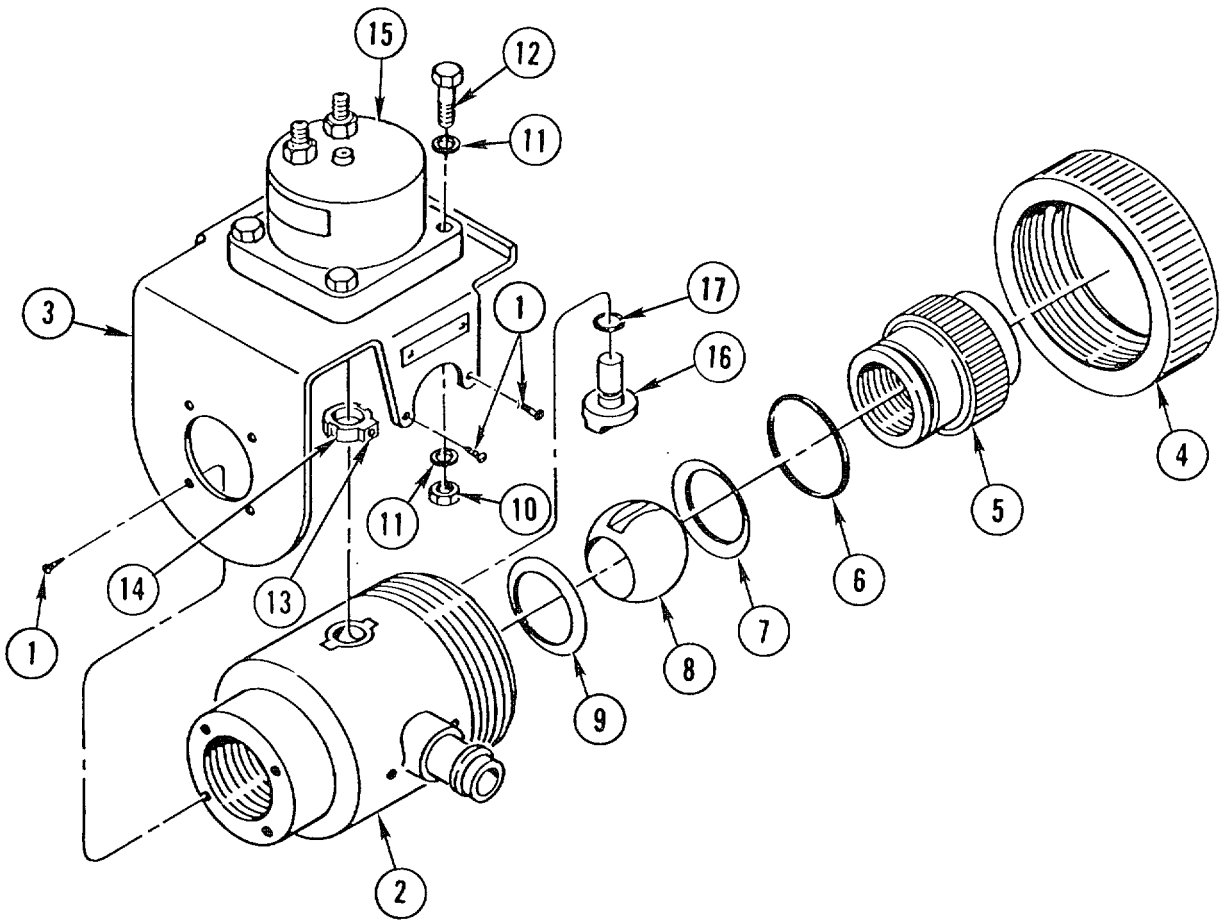

---

**PUMP AND CROSSTUBE ASSEMBLY SPRAY SYSTEM CONTROL REPAIR (CONT)**

---

**C. ASSEMBLY**

- (1) Install new O-ring (1) on turn stem (2).
- (2) Install turn stem (2) in valve body (3) while sliding collar clamp assembly (4) into position between mounting bracket (5) and valve body (3). Push turn stem (2) through collar clamp assembly (4). Tighten Allen screws (6).
- (3) Attach actuator (7) to mounting bracket (5) with four nuts (8), four bolts (9), and eight washers (10). Do not tighten nuts (8).
- (4) Install new teflon seat (11) and new ball valve assembly (12) in valve body (3).

**NOTE**

Ensure turn stem is seated to ball valve assembly for freedom of movement.

- (5) Shine flashlight in inlet end of ball valve. Adjust actuator (7) and ball valve assembly (12) until there is no visible light between teflon seat (11) and ball valve assembly (12) in fully closed position.
- (6) Tighten four nuts (8).
- (7) Install new teflon seat (13), new O-ring (14), end connector (15), and assembly nut (16).
- (8) Install valve body (3) to mounting bracket (5) by installing six screws (17).

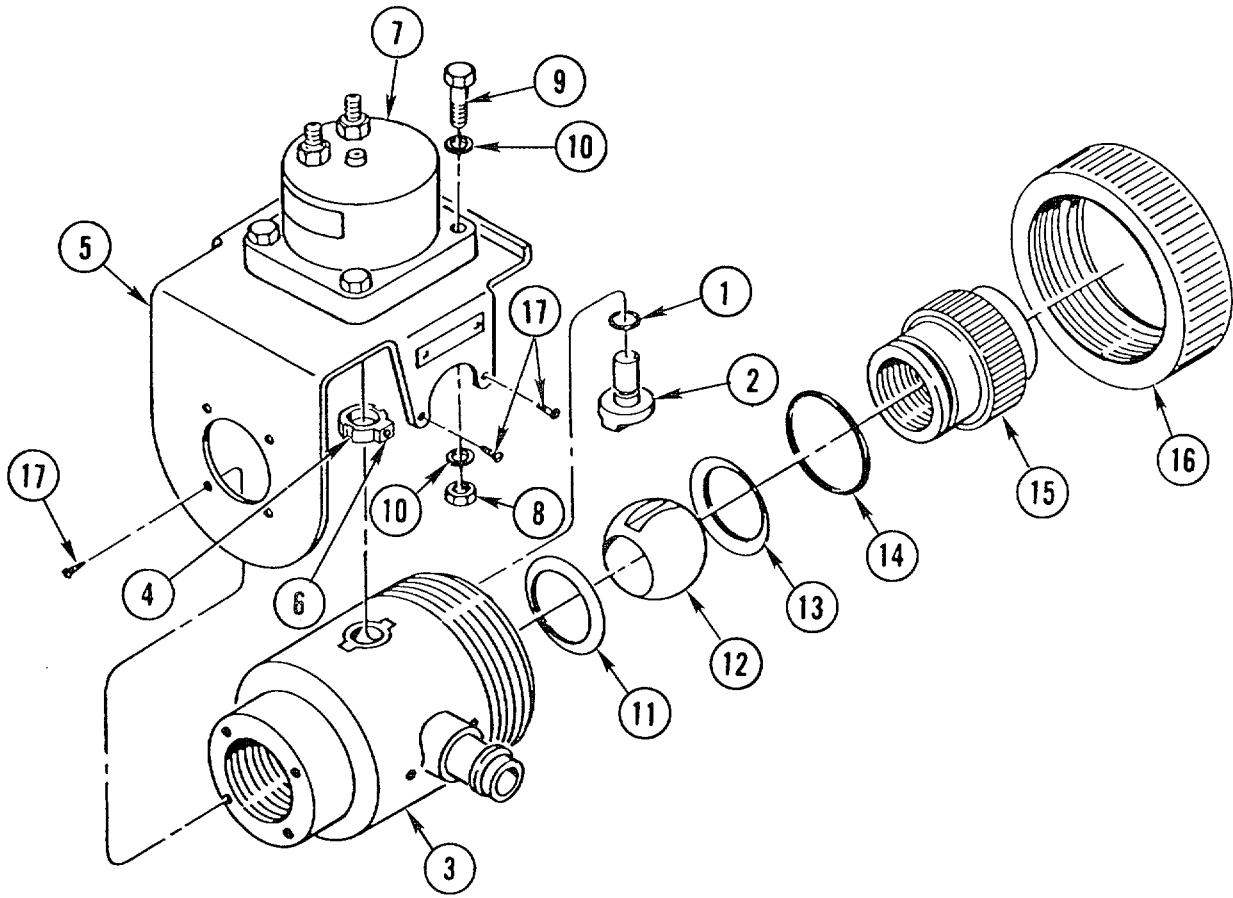

**APPENDIX A  
REFERENCES**

**A-1. SCOPE**

This appendix lists all forms, field manuals, technical manuals, and miscellaneous publications referenced in this manual.

**A-2. FORMS**

Equipment Inspection and Maintenance Worksheet .....	DA Form 2404
Product Quality Deficiency Report .....	SF 368
Recommended Changes to Equipment Technical Manuals .....	DA Form 2028-2
Recommended Changes to Publications and Blank Forms .....	DA Form 2028
Report of Discrepancy.....	SF 364
Transportation Discrepancy Report .....	SF 361
Equipment Control Record .....	DA Form 2408-9

**A-3. TECHNICAL MANUALS**

Clinical Laboratory Procedures: Parasitology .....	TM 8-227-2
Military Entomology Operational Handbook .....	TM 5-632
Painting Instructions for Army Materiel .....	TM 43-0139
Procedures for Destruction of Equipment to Prevent Enemy Use .....	TM 750-244-3
The Army Maintenance Management System (TAMMS) .....	DA Pam 738-750

**A-4. MISCELLANEOUS PUBLICATIONS**

Aerial Disposal of Pesticides .....	AR 40-574
Expendable Items (Except Medical, Class V, Repair Parts, and Heraldic Items) .....	CTA 50-970
Field Hygiene and Sanitation .....	FM 21-10
Hand Portable Fire Extinguishers Approved for Army Use.....	TB 5-4200-200-10
Index of Administrative Publications .....	DA Pam 25-30
Occupational and Environmental Health:	
Hearing Conservation .....	TB-MED-501
Reporting of Transportation Discrepancies in Shipment .....	AR 55-38
Reporting of Item and Packaging Discrepancies .....	AR 735- 11-2
Army Helicopter External Load Operations .....	FM 55-450-1
First Aid for Soldiers .....	FM 21-11
Abbreviations for Use on Drawings, and In Specifications, Standards, and Technical Documents .....	MIL-STD- 12D

## APPENDIX B MAINTENANCE ALLOCATION CHART

### Section I INTRODUCTION

#### B-1. GENERAL

- a. This appendix provides a general explanation of all maintenance and repair functions authorized, at various maintenance levels.
- b. The Maintenance Allocation Chart (MAC) in Section II designates overall authority and responsibility for the performance of maintenance functions on the identified end item or component. The application of the maintenance functions to the end item or component will be consistent with the capacities and capabilities of the designated maintenance levels.
- c. Section III lists the tools and test equipment (both special tools and common tool sets) required for each maintenance function as referenced from Section II.
- d. Section IV contains supplemental instructions and explanatory notes for a particular maintenance function.

#### B-2. MAINTENANCE FUNCTIONS

Maintenance functions will be limited to and defined as follows:

- a. **Inspect.** To determine the serviceability of the Pesticide Dispersion Unit, Multicapability, Helicopter Slung (PDU) by comparing its physical, mechanical, and/or electrical characteristics with established standards through examination (e.g., by sight, sound, or feel).
- b. **Test.** To verify serviceability by measuring the mechanical or electrical characteristics of the PDU and comparing those characteristics with prescribed standards.
- c. **Service.** Operations required periodically to keep the PDU in proper operating condition; i.e., to clean (includes decontaminate, when required), to preserve, to drain, or to paint.
- d. **Adjust.** To maintain or regulate, within prescribed limits, by bringing into proper or exact position, or by setting the operating characteristics to specified parameters.
- e. **Replace.** To remove an unserviceable item and install a serviceable counterpart in its place. Replace is authorized by the MAC and is shown as the 3rd position code of the SMR code.
- f. **Repair.** The application of maintenance services including fault location/troubleshooting, removal/installation, and disassembly/assembly procedures, and maintenance actions to identify troubles and restore serviceability to an item by correcting specific damage, fault, malfunction, or failure in a part, subassembly, module (component or assembly), end item, or system.

**B-3. EXPLANATION OF COLUMNS IN THE MAC, SECTION II**

- a. **Column 1, Group Number.** Column 1 lists functional group code numbers, the purpose of which is to identify maintenance significant components, assemblies, subassemblies, and modules with the next higher assembly. End item group number shall be "00".
- b. **Column 2, Component/Assembly.** Column 2 contains the noun names of components, assemblies, subassemblies, and modules for which maintenance is authorized.
- c. **Column 3, Maintenance Function.** Column 3 lists the functions to be performed on the item listed in Column 2. (For detailed explanation of these functions, see paragraph B-2.)
- d. **Column 4, Maintenance Level.** Column 4 specifies, by the listing of a work-time figure in the appropriate subcolumn(s), the level of maintenance authorized to perform the function listed in Column 3. This figure represents the active time required to perform that maintenance function at the indicated level of maintenance. If the number or complexity of the tasks within the listed maintenance function vary at different levels, appropriate work-time figures will be shown for each level. The work-time figure represents the average time required to restore an item (assembly, subassembly, component, module, end item, or system) to a serviceable condition under typical field operating conditions. This time includes preparation time (including any necessary disassembly/assembly time), troubleshooting/fault location time, and quality assurance/quality control time, in addition to the time required to perform the specific tasks identified for the maintenance functions authorized in the Maintenance Allocation Chart. The symbol designations for the maintenance levels are as follows:

**UNIT**

- C** — Operator or Crew
- O** — Unit Maintenance
- F** — Direct Support Maintenance
- H** — General Support Maintenance

**DEPOT**

- D** — Depot Maintenance

- e. **Column 5, Tools and Equipment.** Column 5 specifies by code, those common tool sets (not individual tools) and special tools, Test Measurement and Diagnostic Equipment (TMDE), and support equipment required to perform the designated function.
- f. **Column 6, Remarks.** This column shall, when applicable, contain a letter code, in alphabetical order, which shall be keyed to the remarks contained in Section IV.

**B-4. EXPLANATION OF COLUMNS IN TOOL AND TEST EQUIPMENT REQUIREMENTS, SECTION III**

- a. **Column 1, Reference Code.** The tool and test equipment code correlates with a code used in the MAC, Section II, Column 5.
- b. **Column 2, Maintenance Level.** The lowest level of maintenance authorized to use the tool or test equipment.
- c. **Column 3, Nomenclature.** Name or identification of the tool or test equipment.
- d. **Column 4, National/NATO Stock Number.** The National/NATO Stock Number (NSN) of the tool or test equipment.
- e. **Column 5, Tool Number.** The manufacturer's part number.

**B-5. EXPLANATION OF COLUMNS IN REMARKS, SECTION IV**

- a. **Column 1, Reference Code.** The letter code recorded in Column 6 of the MAC, Section II.
- b. **Column 2, Remarks.** This column lists information pertinent to the maintenance function being performed as indicated in the MAC, Section II.

**SECTION II. MAINTENANCE ALLOCATION CHART  
FOR  
PESTICIDE DISPERSAL UNIT, MULTICAPABILITY, HELICOPTER SLUNG**

(1) GROUP NUMBER	(2) COMPONENT/ASSEMBLY	(3) MAINTENANCE FUNCTION	(4) MAINTENANCE LEVEL					(5) TOOLS AND EQPT	(6) REMARKS
			C	O	F	H	D		
01	Pesticide Dispersal Unit								
0101	Bucket Assembly	Inspect Adjust Service Replace	0.1	0.2 0.3 2.0				1	
010101	Door Lid Assembly	Inspect Repair Replace	0.3	2.0 1.0				7 1 2	
010102	Tail Fin	Inspect Replace	0.1	0.5				1	
010103	Frame	Inspect	0.1						
010104	Sling Hook Assembly	Inspect Service Replace	0.1 0.2	0.5				2	
0102	Engine and Pump Assembly	Inspect Test Service Replace	0.2	0.2 0.5 2.0				2 1 3	
010201	Key Switchbox Assembly	Repair Replace		1.0	1.0			1 1	
010202	Carburetor	Repair Adjust Replace		1.0 0.2 0.8				2 1 1	
010203	Air Cleaner	Inspect Service Repair Replace	0.1 0.3	0.5 0.8				2 1	
010204	Muffler Assembly	Inspect Service Repair Replace	0.1	1.0 1.0 0.5				1 1	
010205	Spark Plug	Inspect Adjust Replace		0.2 0.2 0.3				2 2	
010206	Oil Fill and Drain Assembly	Inspect Service Repair	0.1 0.2	1.0				2	



**SECTION II. MAINTENANCE ALLOCATION CHART  
FOR  
PESTICIDE DISPERSAL UNIT, MULTICAPABILITY, HELICOPTER SLUNG**

(1) GROUP NUMBER	(2) COMPONENT/ASSEMBLY	(3) MAINTENANCE FUNCTION	(4) MAINTENANCE LEVEL					(5) TOOLS AND EQPT	(6) REMARKS
			C	O	F	H	D		
010207	Starter Motor	Inspect	0.1						
		Test		0.4				2	
		Repair			1.0			3,5	
		Replace			0.5			1	
010208	Hydraulic Pump Assembly	Inspect			1.0				
		Repair			1.0			2	
		Replace		1.0				2	
0103	Gas Tank Assembly	Inspect	0.1	1.0					
		Repair		1.0				2	
		Replace		1.0					
0104	Battery/Hydraulic Assembly	Inspect	0.3						
		Service		0.8					
		Replace		1.2				1	
010401	All Angle Isolator	Inspect		0.3					
		Replace		1.0				1	
010402	Battery Cable	Inspect	0.1						
		Service	0.2					1	
		Replace		1.0					
010403	Secondary Hydraulic Manifold Assembly	Inspect	0.1						
		Service		0.3				1	
		Repair			3.0			2	
		Replace		2.0				1	
010404	Battery Assembly	Inspect	0.2						
		Service	0.3						
		Replace		1.0				1	
010405	Hydraulic Reservoir Primary Manifold Assembly	Inspect	0.1						
		Service		0.2					
		Repair		3.0				1	
		Replace		3.0				1	
010406	Primary Hydraulic Manifold Assembly	Inspect	0.2						
		Repair			3.0			2	
		Replace		2.0				1	
0105	Controls								
010501	Bucket Harness	Inspect	0.5						
		Replace		1.0				2	
010502	Hand Control Assembly/Electrical-Safety Cable Assembly	Inspect	0.1						
		Service		0.1					
		Repair			2.0			2	
		Replace		0.1				2	

**SECTION II. MAINTENANCE ALLOCATION CHART  
FOR  
PESTICIDE DISPERSAL UNIT, MULTICAPABILITY, HELICOPTER SLUNG**

(1) GROUP NUMBER	(2) COMPONENT/ASSEMBLY	(3) MAINTENANCE FUNCTION	(4) MAINTENANCE LEVEL					(5) TOOLS AND EQPT	(6) REMARKS
			C	O	F	H	D		
02	Liquid Dispersal System								
0201	Pump and Crosstube Assembly	Inspect Service Repair Replace	0.4	0.4 2.0 3.0				1 2 2,5	
020101	Level Switch	Inspect Replace		0.2 3.0				1	
020102	Hydraulic Motor and Chemical Pump Assembly	Inspect Replace	0.1	1.0				1	
02010201	Chemical Pump	Replace Repair		0.7	0.7			1	
02010202	Hydraulic Motor	Inspect Replace Repair	0.1	0.7	0.7			1 6	
020103	Spray System Control	Inspect Repair Replace	0.1		1.0			2 2	
020104	Strainer	Inspect Service	0.1 0.3					1	
0202	Low Volume Boom Assembly	Inspect Service Repair Replace	0.5 1.0	1.0 1.0				1	
020201	Spray Nozzles	Inspect Service Repair Replace	0.3	1.0 1.0 1.0					
0203	Ultra-Low Volume Boom Assembly	Inspect Service Repair Replace	0.1	0.5 1.0 1.0				2 1,5	
020301	Rotary Atomizer	Inspect Service Repair	0.1	0.5 0.5				2	
03	Solid Dispersal System								
0301	Slinger/Hopper Assembly	Inspect	0.2						
030101	Motor and Slinger Assembly	Inspect Repair Replace	0.3	1.0 0.5				1 1	

**SECTION II. MAINTENANCE ALLOCATION CHART  
FOR  
PESTICIDE DISPERSAL UNIT, MULTICAPABILITY, HELICOPTER SLUNG**

(1) GROUP NUMBER	(2) COMPONENT/ASSEMBLY	(3) MAINTENANCE FUNCTION	(4) MAINTENANCE LEVEL					(5) TOOLS AND EQPT	(6) REMARKS
			C	O	F	H	D		
03010101	Hydraulic Motor	Repair			0.7			2	
030102	Hopper Assembly	Inspect	0.3	0.3					
		Repair		0.5				1	
		Replace		0.5				1	
04	Dolly Assembly	Inspect		0.1					
		Repair		0.8				1	
		Replace		0.2				1	

**SECTION III. TOOL AND TEST EQUIPMENT REQUIREMENTS  
FOR  
PESTICIDE DISPERSAL UNIT, MULTICAPABILITY, HELICOPTER SLUNG**

TOOL OR TEST EQUIPMENT REF CODE	MAINTENANCE CATEGORY	NOMENCLATURE	NATIONAL/NATO STOCK NUMBER	TOOL NUMBER
1	O,F	Tool Kit, General Mechanics: Automotive	5180-00-177-7033	
2	O,F	Shop Equipment, Automotive Maintenance and Repairs, Organizational Maintenance, Common No. 1, Less Power	4910-00-754-0654	
3	O,F	Shop Equipment, General Purpose Repair, Semi-Trailer Mounting	4940-00-287-4894	
4	O,F	Multimeter	6825-00-999-6282	
5	O,F	Pliers, Snap Ring	5120-00-801-0958	
6	O,F	Riveter, Blind, Hand	5120-00-973-0377	PRG 440

**SECTION IV. REMARKS  
FOR  
PESTICIDE DISPERSAL UNIT, MULTICAPABILITY, HELICOPTER SLUNG**

<b>REFERENCE CODE</b>	<b>REMARKS</b>

## APPENDIX C COMPONENTS OF END ITEM AND BASIC ISSUE ITEMS LISTS

### Section I. INTRODUCTION

#### C-1. SCOPE

This appendix lists Components of End Item (COEI) and Basic Issue Items (BII) for the Pesticide Dispersal Unit, Multicapability, Helicopter Slung (PDU) to help you inventory items required for safe and efficient operation.

#### C-2. GENERAL

The Components of End Item and Basic Issue Items Lists are divided into the following sections:

**a. Section II. Components of End Item.** This listing is for informational purposes only, and is not authority to requisition replacements. These items are part of the end item, but are removed and packaged separately for transportation or shipment. As part of the end item, these items must be with the end item whenever it is issued or transferred between property accounts. Illustrations are furnished to assist you in identifying the items.

**b. Section III. Basic Issue Items.** These are the minimum essential items required to place the PDU in operation, to operate it, and to perform emergency repairs. Although shipped separately packaged, BII must be with the PDU during operation and whenever it is transferred between property accounts. The illustrations will assist you with hard-to-identify items. This manual is your authority to request/requisition replacement BII, based on TOE/MTOE authorization of the end item.

#### C-3. EXPLANATION OF COLUMNS

The following is an explanation of columns found in the tabular listings:

**a. Column (1) -- Illustration Number (ILLUST NUMBER).** This column indicates the number of the illustration in which the item is shown.

**b. Column (2) - National Stock Number.** Indicates the National Stock Number assigned to the item and will be used for requisitioning purposes.

**c. Column (3) - Description.** Indicates the Federal item name and, if required, a minimum description to identify and locate the item. The last line for each item indicates the CAGE (Contractor and Government Entity) Code (in parentheses) followed by the part number.

**d. Column (4) - Usable on Code.** This column indicates the Provisioning Control Code (PCC) that identifies the equipment within the provisioning system.

**e. Column (5) - Unit of Measure (U/M).** Indicates the measure used in performing the actual operational/maintenance function. This measure is expressed by a two-character alphabetical abbreviation (e.g., EA, IN, PR).

**f. Column (6) - Quantity Required (QTY RQR).** Indicates the quantity of the item authorized to be used with the PDU.

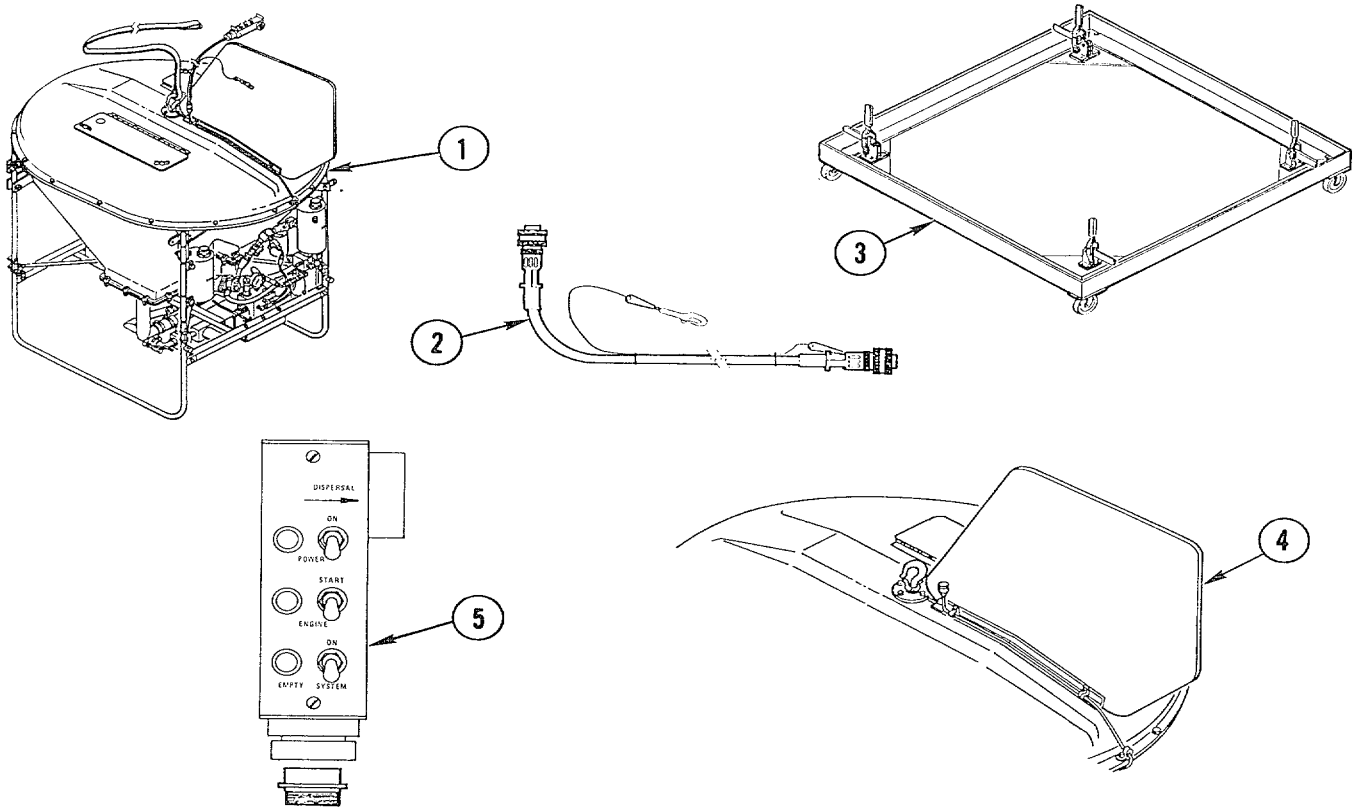

(1) ILLUS NUMBER	(2) NATIONAL STOCK NUMBER	(3) DESCRIPTION	(4) USABLE ON CODE	(5) U/M	(6) QTY. RQR
1	3740-02-262-8707	Pesticide Dispersal Unit, Multicapability, Helicopter Slung (53945) 96800		EA	1
2		Cable, Electrical-Safety (Mount on 96800) (53945) 6629		EA	1
3		Dolly Assembly (Mount on 96800) (53945) 6890		EA	1
4		Fin, Tail (Mount on 96800) (53945) 6089		EA	1
5		Hand Control Assembly (Mount on 96800) (53945) 6670		EA	1

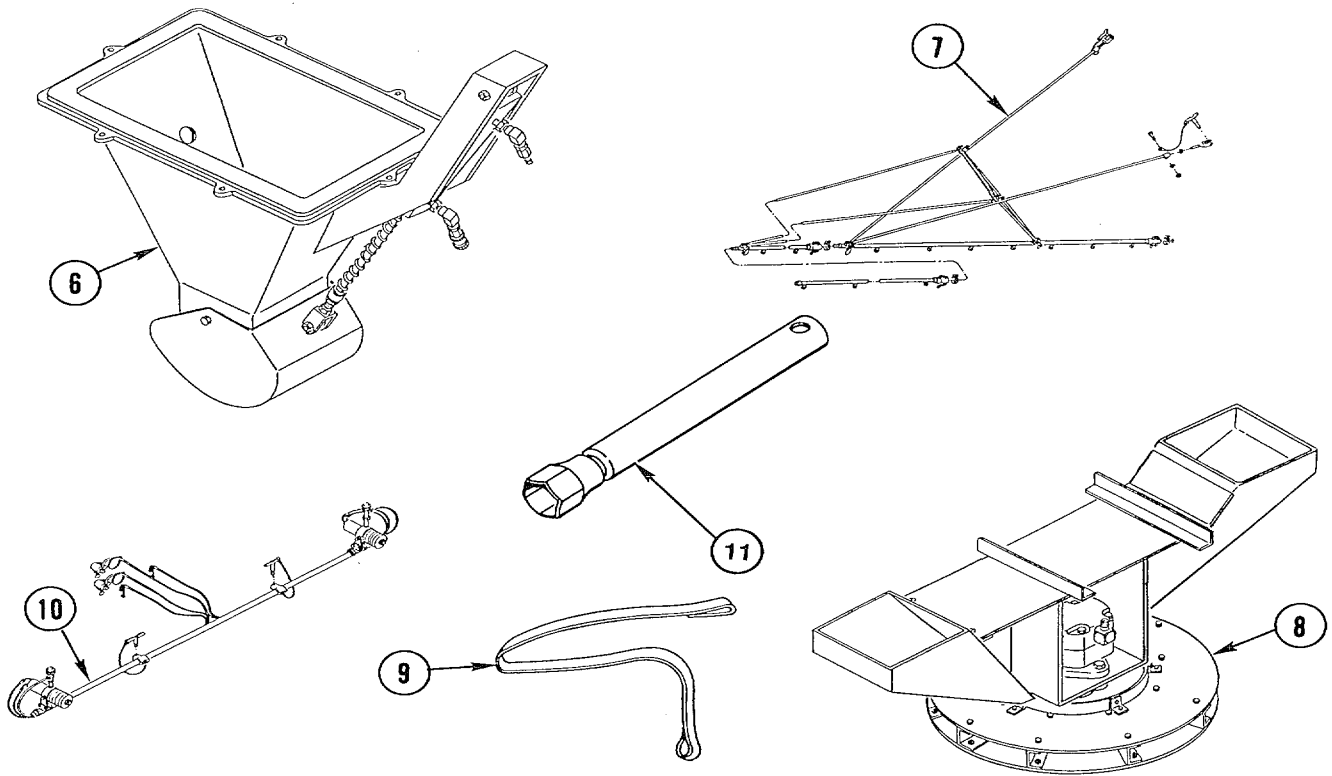

(1) ILLUS NUMBER	(2) NATIONAL STOCK NUMBER	(3) DESCRIPTION	(4) USABLE ON CODE	(5) U/M	(6) QTY. RQR
6		Hopper Assembly (Mount on 96800) (53945) 96735		EA	2
7		LV Boom Assembly (Mount on 96800) (53945) 96821		EA	1
8		Motor and Slinger Assembly (Mount on 96800) (53945) 96680		EA	1
9		Strap, Lifting (Mount on 96800) (53945) 6679		EA	1
10		ULV Boom Assembly (Mount on 96800) (53945) 96710		EA	1
11		Wrench, Spark Plug		EA	1



Section III. BASIC ISSUE ITEMS (BII)

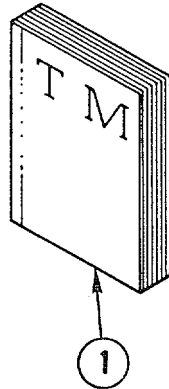

(1) ILLUS NUMBER	(2) NATIONAL STOCK NUMBER	(3) DESCRIPTION	(4) USABLE ON CODE	(5) U/M	(6) QTY. RQR
1		Technical Manual (For 96800) (53945) TM 5-3740-218-13&P		EA	1

**APPENDIX D  
ADDITIONAL AUTHORIZATION LIST**

**D-1. SCOPE**

This appendix lists additional items you are authorized for the support of the Pesticide Dispersal Unit, Multicapability, Helicopter Slung (PDU).

**D-2. GENERAL**

This list identifies items that do not have to accompany the PDU and that do not have to be turned in with it. The items are all authorized to you by CTA, MTOE, TDA, or JTA.

**D-3. EXPLANATION OF LISTING**

National stock numbers, descriptions, and quantities are provided to help you identify and request the additional items you require to support the PDU. The items are listed in alphabetical sequence by item name.

Section II. ADDITIONAL AUTHORIZATION LIST

(1) NATIONAL STOCK NUMBER	(2) DESCRIPTION		(3) U/M	(4) QTY AUTH
	CAGE & PART NUMBER	USABLE ON CODE		
5120-00-240-5364	Drive Ratchet, 3/8-in.		EA	1
5120-00-273-9203	Extension, 3/8-in. x 5-in.		EA	1
	Gage, 0-100 psi		EA	1
5120-00-494-1889	Pliers, C-Clamp, 8-in. O/A/L		EA	1
5120-00-222-8852	Screwdriver, 1/4-in.		EA	1
5120-00-227-6702	Socket (3/8-in. Drive), 3/8-in.		EA	1
5120-00-227-6703	Socket (3/8-in. Drive), 7/16-in.		EA	1
	T-Fitting, 1/4-in.		EA	1
5120-00-227-2342	Wrench, Open End, 3/8-in. x 7/16-in.		EA	1

**APPENDIX E**  
**EXPENDABLE SUPPLIES AND MATERIALS LIST**

**Section I. INTRODUCTION**

**E-1. SCOPE**

This appendix lists expendable supplies and materials you will need to operate and maintain the Pesticide Dispersal Unit, Multicapability, Helicopter Slung. These items are authorized to you by CTA 50-970, Expendable Items (Except Medical, Class V, Repair Parts, and Heraldic Items).

**E-2. EXPLANATION OF COLUMNS**

a. **Column (1) - Item Number.** This number is assigned to the entry in the listing and is referenced in the narrative instructions to identify the material.

b. **Column (2) - Level.** This column identifies the lowest level of maintenance that requires the listed item. Enter as applicable:

- C - Operator/Crew
- O - Unit Maintenance
- F - Direct Support Maintenance

c. **Column (3) - National Stock Number.** This is the National stock number assigned to the item; use it to request or requisition the item.

d. **Column (4) - Description.** Indicates the Federal item name and, if required, a description to identify the item. The last line for each item indicates the CAGE (Contractor and Government Entity) code in parentheses followed by the part number.

e. **Column (5) - Unit of Measure (U/M).** Indicates the measure used in performing the actual maintenance function. This measure is expressed by a two-character alphabetical abbreviation (e.g., EA, IN, PR). If the unit of measure differs from the unit of issue, requisition the lowest unit of issue that will satisfy your requirements.

Section II. EXPENDABLE SUPPLIES AND MATERIALS

(1) ITEM NUMBER	(2) LEVEL	(3) NATIONAL STOCK NUMBER	(4) DESCRIPTION	(5) U/M
1	O		Assembly, Wire Rope (84256) L-8-T6-V	
2	F	7920-00-062-5468	Brush (53945) 31210-ZE3-013	
3	O		Clamp, Cushion (96906) MS21919WDG20	
4	C	7920-00-205-1711	Cloth, Lint-Free Bale	EA
5	C,O		Contact Cement, Barge All-Purpose	
6	O	6810-00-249-9354	Electrolyte	
7	O	File, Emery Stone		
8	O		Filter, 10-Micron (02249) K22001	
9	O	Filter, Drain Tube	(53945) 17367-413-690	
10	O,F	9150-00-698-2382	Fluid, Hydraulic, Shell-Tellus 68 or equivalent	
11	O		Gasket (53945) 539	
12	O		Gasket (53945) 2025	
13	O		Gasket (53945) 2027	
14	O		Gasket (53945) 6601	
15	O		Gasket (53945) 123538	

(1) ITEM NUMBER	(2) LEVEL	(3) NATIONAL STOCK NUMBER	(4) DESCRIPTION	(5) U/M
16	O		Gasket (53945) 15621-896-010	
17	O		Gasket, Lid (53945) 6641	
18	O		Gasket, Motor (65387) 360011	
19	C,O,F	9130-00-160-1818	Gasoline, Regular Automotive	
20	C,O		Grease, Beeco Seal	
21	C	9150-00-190-0804	Grease, General Purpose	
22	O	5325-00-406-5458	Grommet (72794) GP5	
23	F	5325-00-174-9003	Grommet (70485) 452	
24	F		Kit, Parts Repair (53945) 4439	
25	F		Kit, Parts Repair (12008) 24300-902	
26	F		Kit, Parts Repair (12008) 1402635-001	
27	F		Kit, Parts Repair (53945) 152756	
28	F		Kit, Parts Repair (53945) 152757	
29	F		Kit, Parts Repair (53945) 152766	
30	F		Kit, Parts Repair (53945) 152767	
31	F		Kit, Parts Repair (53945) 152768	
32	F		Kit, Parts Repair (53945) 152769	

(1) ITEM NUMBER	(2) LEVEL	(3) NATIONAL STOCK NUMBER	(4) DESCRIPTION	(5) U/M
33	F		Kit, Seal	
34	F	8030-00-981-7005	Loctite (05972) AA15-1	
35	C,O,F	7050-00-961-7663	Lubriplate (Lubricant) (90536) ST40334	
36	C,O	9150-00-186-6668 9150-00-188-9858	Oil, Engine, MIL-L-2104, Type OE/HDO	QT GAL (5 GAL)
37	C,O		Oil, General Purpose	
38	C,O	9150-00-491-7179	Oil, Lubricating	
39	C,O	9150-00-111-0209	Oil, Preservative MIL-L-212-60P-10	
40	O,F	9150-00-186-6705	Oil, SAE 10W-40	
41	F		O-Ring (02697) 2-011-V747-75	
42	O		O-Ring (53945) 128135	
43	F		O-Ring (02697) 2-121-V747-75	
44	F		O-Ring	
45	O	5340-00-052-3839	Pin (96906) MS17985-507	
46	O		Pin, Cotter	
47	F		Plug, Snap, Male (2V131) 82M-157-NB	
48	F		Receptacle, Female (2V131) 82F-157-NBL	
49	O		Rivet, Pop (53945) 114660	
50	O		Seal (53945) 17252-899-000	

(1) ITEM NUMBER	(2) LEVEL	(3) NATIONAL STOCK NUMBER	(4) DESCRIPTION	(5) U/M
51	O		Seal, Bearing (65387) 360015	
52	O		Seal, Front (65387) 360048	
53	O		Seal, Plate (65387) 360050	
54	O	6850-00-914-8374	Sealant, Silicone (0688) PSI-8430-1	
55	O,F	6920-01-239-1562	Sealant, Thread (05972) 87	
56	O,F		Sealer, Pipe Joint	
57	O	8950-00-202-9611	Soda, Baking	
58	O,F	3439-01-074-4983	Solder, Rosin Core	
59	C,O,F	6850-00-664-5685 6850-00-281-1985	Solvent, Drycleaning, P-D-680	QT GAL
60	O,F		Solvent, High Flashpoint	
61	O	8030-00-889-3534	Tape, Teflon, Antiseize	
62	O	5340-01-248-4747	Tie, Cable Pack/100 (39428) 7130K14	
63	O,F	5970-00-032-0291	Tubing, Heat Shrink Pack/Assorted (53945) 107850	
64	O,F	3439-01-031-7173	Wick, Solder (54450) 100	
65			Gasket (53945) 123563	
66			Gasket (53945) 123565	



**APPENDIX F  
UNIT, AND DIRECT SUPPORT MAINTENANCE  
REPAIR PARTS AND SPECIAL TOOLS LIST**

**Section I. INTRODUCTION**

**F-1. SCOPE.** This RPSTL lists and authorizes spares and repair parts; special tools; special test, measurement, and diagnostic equipment (TMDE); and other special support equipment required for performance of unit and direct support maintenance of the Pesticide Dispersal Unit, Multicapability, Helicopter Slung. It authorizes the requisitioning, issue, and disposition of spares, repair parts and special tools as indicated by the source, maintenance and recoverability (SMR) codes.

**F-2. GENERAL.** In addition to this section, Introduction, this Repair Parts and Special Tools List is divided into the following sections:

**a. Section II. Repair Parts List.** A list of spares and repair parts authorized by this RPSTL for use in the performance of maintenance. This list also includes parts which must be removed for replacement of the authorized parts. Parts lists are composed of functional groups in ascending alphanumeric sequence, with the parts in each group listed in ascending figure and item number sequence. Bulk materials are listed in item name sequence. Repair parts kits are listed separately in their own functional group within Section II. Repair parts for repairable special tools are also listed in this section. Items are shown in the associated illustration(s)/figure(s).

**b. Section III. Special Tools List.** A list of special tools, special TMDE, and other special support equipment authorized by this RPSTL (as indicated by Basis of Issue (BOI) information in DESCRIPTION AND USABLE ON CODE column) for the performance of maintenance.

**c. Section IV. Cross-references Indexes.** A list, in National Item Identification Number (NIIN) sequence, of all National stock numbered items appearing in the listing, followed by a list in alphanumeric sequence of all part numbers appearing in the listings. National stock numbers and part numbers are cross referenced to each illustration figure and item number appearance. The figure and item number index lists figure and item number in alphanumeric sequence and cross references NSN, CAGEC and part number.

**F-3. EXPLANATION OF COLUMNS (SECTION II AND SECTION III).**

**a. ITEM NO. (Column (1)).** Indicates the number used to identify items called out in the illustration.

**b. SMR Code (Column (2)).** The Source, Maintenance, and Recoverability (SMR) code is a 5-position code containing supply/requisitioning information, maintenance category authorization criteria, and disposition instruction, as shown in the following breakout:

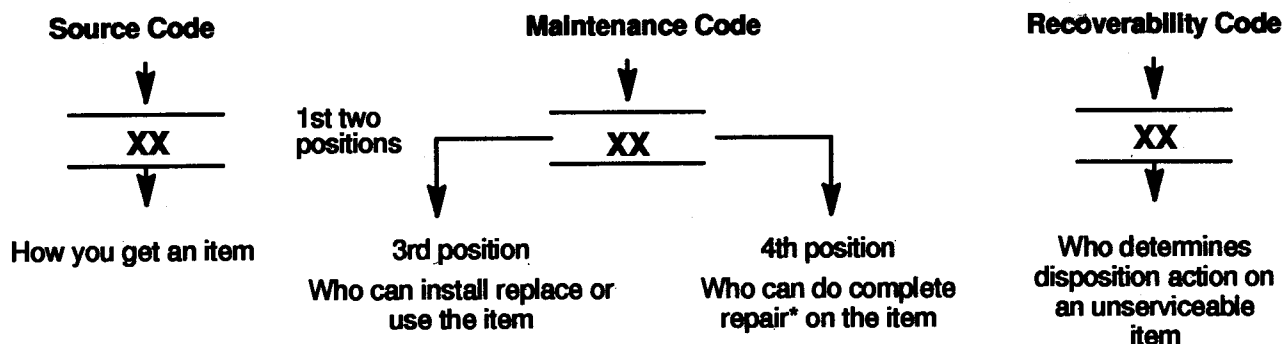

\* Complete Rear: Maintenance capacity, capability, and authority to perform all corrective maintenance tasks of the "Repair" function in a use/user environment in order to restore serviceability to a failed item.

**(1) Source Code.** The source code tells you how you get an item needed for maintenance, repair, or overhaul of an end item/equipment. Explanations of source codes follow.

<b>Code</b>	<b>Explanation</b>
PA PB PC** PD PE PF PG	<p>Stocked items; use the applicable NSN to request/requisition items with these source codes. They are authorized to the category indicated by the code entered in the 3rd position of the SMR code.</p> <p>**NOTE: Items coded PC are subject to deterioration.</p>
KD KF KB	

**Explanation**

MO (Made at org AVUM level) MF (Made at DS/AVUM level) MH (Made at GS level) ML (Made at Specialized Repair Activity (SRA)) MD (Made at Depot)	<p>Items with these codes are not to be requested/requisitioned individually. They must be made from bulk material which is identified by the part number in the DESCRIPTION and USABLE ON CODE (UOC) column and listed in the Bulk Material group of the repair parts list in the RPSTL. If the item is authorized to you by the 3rd position code of the SMR code, but the source code indicates it is made at a higher level, order the item from the higher level of maintenance.</p>
AO (Assembled by org AVUM Level) AF (Assembled by DS/AVUM Level) AH (Assembled by GS Category) AL (Assembled by SRA) AD (Assembled by Depot)	

<b>Code</b>	<b>Explanation</b>
-------------	--------------------

- |    |  |
|----|--|
| XA | - - Do not requisition an "XA"-coded item. Order its next higher assembly. (Also, refer to the NOTE below.)                                    |
| XB | - - If an "XB" item is not available from salvage, order it using the FSCM and part number given.  |
| XC | - - Installation drawing, diagram, instruction sheet, field service drawing, that is identified by manufacturer's part number.                 |
| XD | - - Item is not stocked. Order an "XD"-coded item through normal supply channels using the FSCM and part number given, if no NSN is available. |

**NOTE**

Cannibalization or controlled exchange, when authorized, may be used as a source of supply for items with the above source codes, except for those source coded "XA" or those aircraft support items restricted by requirements of AR 750-1

**(2) Maintenance Code.** Maintenance codes tell you the level(s) of maintenance authorized to USE and REPAIR support items. The maintenance codes are entered in the third and fourth positions of the SMR code as follows:

- (a) The maintenance code entered in the third position tells you the lowest maintenance level authorized to remove, replace, and use an item. The maintenance code entered in the third position will indicate authorization to the following levels of maintenance.

<b>Code</b>	<b>Application/Explanation</b>
C -	Crew or operator maintenance done within the organization or aviation unit maintenance.
O -	Organizational or aviation unit category can remove, replace, and use the item.
F -	Direct support or aviation intermediate level can remove, replace, and use the item.
H -	General support level can remove, replace, and use the item.
L -	Specialized repair activity can remove, replace, and use the item.
D -	Depot level can remove, replace, and use the item.

- (b) The maintenance code entered in the fourth position tells whether or not the item is to be repaired and identifies the lowest maintenance level with the capability to do complete repair (i.e., perform all authorized repair functions). NOTE: Some limited repair may be done on the item at a lower level of maintenance, if authorized by the Maintenance Allocation Chart (MAC) and SMR codes. This position will contain one of the following maintenance codes.

<b>Code</b>	<b>Application/Explanation</b>
O -	Organizational or (aviation unit) is the lowest level that can do complete repair of the item.
F -	Direct support or aviation intermediate level is the lowest level that can do complete repair of the item.
H -	General Support is the lowest level that can do complete repair of the item.
L -	Specialized repair activity is the lowest level that can do complete repair of the item.
D -	Depot is the lowest level that can do complete repair of the item.
Z -	Nonreparable. No repair is authorized.
B -	No repair is authorized. (No parts or special tools are authorized for the maintenance of a "B" coded item). However, the item may be reconditioned by adjusting, lubricating, etc., at the user level.

**(3) Recoverability Code.** Recoverability codes are assigned to items to indicate the disposition action on unserviceable items. The recoverability code is entered in the fifth position of the SMR Code as follows:

**Recoverability  
Codes**

**Application/Explanation**

- Z - Nonreparable item. When unserviceable, condemn and dispose of the item at the level of maintenance shown in 3rd position of SMR Code.
- O - Repairable item. When not economically repairable, condemn and dispose of the item at organizational or aviation unit level.
- F - Repairable item. When uneconomically repairable, condemn and dispose of the item at the direct support or aviation intermediate level.
- H - Repairable item. When uneconomically repairable, condemn and dispose of the item at the general support level.
- D - Repairable item. When beyond lower level repair capability, return to depot. Condemnation and disposal of item not authorized below depot level.
- L - Repairable item. Condemnation and disposal not authorized below specialized repair activity (SRA).
- A - Item requires special handling or condemnation procedures because of specific reasons (e.g., precious metal content, high dollar value, critical material, or hazardous material). Refer to appropriate manuals/directives for specific instructions.

**c. CAGEC (Column (3)).** The Commercial and Government Entity Code (CAGEC) is a 5-digit numeric code which is used to identify the manufacturer, distributor, or Government agency, etc. that supplies the item.

**d. PART NUMBER (Column (4)).** Indicates the primary number used by the manufacturer, (individual, company, firm, corporation, or Government activity), which controls the design and characteristics of the item by means of its engineering drawings, specifications, standards, and inspection requirements to identify an item or range of items.

**NOTE**

When you use an NSN to requisition an item, the item you receive may have a different part number from the part ordered.

**e. DESCRIPTION AND USABLE ON CODE (UOC) (Column (5)).** This column includes the following information:

- (1) The Federal item name and, when required, a minimum description to identify the item.
- (2) The physical security classification of the item is indicated by the parenthetical entry, e.g., Phy Sec C1 (C)-Confidential, Phy Sec CI (S)-Secret, Phy Sec CI (T)-Top-Secret.
- (3) Items that are included in kits and sets are listed below the name of the kit or set.
- (4) Spare/repair parts that make up an assembled item are listed immediately following the assembled item line entry.
- (5) Part numbers of bulk materials are referenced in this column in the line entry for the item to be manufactured/fabricated.
- (6) When the item is not used with all serial numbers of the same model, the effective serial numbers are shown on the last line(s) of the description (before UOC).
- (7) The usable on code, when applicable (reference paragraph 5, Special Information).

- (8) In the Special Tools List Section, the basis of issue (BOI) appears as the last line(s) in the entry for each special tool, special TMDE, and other special support equipment. When density of equipment supported exceeds density spread indicated in the basis of issue, the total authorization is increased proportionately.
- (9) The statement "END OF FIGURE" appears just below the last item description in Column (5) for a given figure in both Section II and Section III.
- (10) The indenture, shown as dots appearing before the repair part, indicates that the item is a repair part of the next higher assembly.

f. **QTY (Column (6)).** The QTY (quantity per figure) column indicates the quantity of the item used in the breakout shown on the illustration figure, which is prepared for a functional group, subfunctional group, or an assembly. A "V" appearing in the column in lieu of a quantity indicates that the quantity is variable and may vary from application to application.

**F-4. EXPLANATION OF COWMNS (SECTION IV).**

**a. NATIONAL STOCK NUMBER (NSN) INDEX.**

- (1) **STOCK NUMBER Column.** This column lists the NSN in national item identification number (NIIN) sequence. The NIIN consists of the last nine digits of the NSN, i.e.

NSN
5305-01-574-1467
NIIN

When using this column to locate an item, ignore the first four digits of the NSN. However, the complete NSN should be used when ordering items by stock number.

- (2) **FIG. Column.** This column lists the number of the figure where the item is identified/located. The figures are in numerical order in Section II and Section III.
- (3) **ITEM Column.** The item number identifies the item associated with the figure listed in the adjacent FIG. column. This item is also identified by the NSN listed on the same line.

b. **PART NUMBER INDEX.** Part numbers in this index are listed in ascending alphanumeric sequence (i. e., vertical arrangement of letter and number combinations which place the first letter or digit of each group in order A through Z, followed by the numbers 0 through 9, and each following letter or digit in like order).

- (1) **CAGEC column.** The Commercial and Government Entity Code (CAGEC) is a 5-digit numeric code used to identify the manufacturer, distributor, or Government agency that supplies the item.
- (2) **PART NUMBER Column.** Indicates the primary number used by the manufacturer (individual, firm, corporation, or Government activity), which controls the design and characteristics of the item by means of its engineering drawings, specifications, standards, and inspection requirements to identify an item or range of items.
- (3) **STOCK NUMBER Column.** This column lists the NSN for the associated part number and manufacturer identified in the PART NUMBER and FSCM columns to the left.
- (4) **FIG. Column.** This column lists the number of the figure where the item is identified/located in Sections II and III.

- (5) **ITEM Column**. The item number is that number assigned to the item as it appears in the figure referenced in the adjacent figure number column.

**c. FIGURE AND ITEM NUMBER INDEX.**

- (1) **FIG. Column**. This column lists the number of the figure where the item is identified/located in Section II and Section III.
- (2) **ITEM Column**. The item number is that number assigned to the item as it appears in the figure referenced in the adjacent figure number column.
- (3) **STOCK NUMBER Column**. This column lists the NSN for the item.
- (4) **FSCM Column**. The Federal Supply Code for Manufacturer (FSCM) is a 5-digit numeric code used to identify the manufacturer, distributor, or Government agency/activity that supplies the item.
- (5) **PART NUMBER Column**. Indicates the primary number used by the manufacturer (individual, firm, corporation, or Government activity), which controls the design and characteristics of the item by means of its engineering drawings, specifications, standards, and inspection requirements to identify an item or range of items.

**F-5. SPECIAL INFORMATION.**

**a. USABLE ON CODE.** The usable on code appears in the lower left corner of the Description column heading. Usable on codes are shown as "UOC:.." in the Description Column (justified left) on the last line of the applicable item description/nomenclature. Uncoded items are applicable to all models.

**b. ASSOCIATED PUBLICATIONS.** The publications listed below pertain to the Lubricating and Servicing Unit and its components.

**F-6. HOW TO LOCATE REPAIR PARTS.**

**a. When National Stock Numbers or Part Numbers are NOT Known.**

- (1) **First.** Using the table of contents, determine the assembly or subassembly group to which the item belongs. This is necessary since figures are prepared for assembly groups and subassembly groups, and listings are divided into the same groups.
- (2) **Second.** Find the figure covering the assembly group or subassembly group to which the item belongs.
- (3) **Third.** Identify the item on the figure and note the item number.
- (4) **Fourth.** Refer to the Repair Parts List for the figure to find the part number for the item number noted on the figure.

**b. When National Stock Number or Part Number is Known:**

- (1) **First.** Using the of National Stock Number and Part Numbers, find the pertinent National Stock Number or Part Number. The NSN index is in National Item Identification Number (NIIN) sequence (see c-4a.(1)). The part numbers in the Part Number index are listed in ascending alphanumeric sequence (see paragraph c-4.b). Both indexes cross-reference you to the illustration figure and item number of the item you are looking for.
- (2) **Second.** After finding the figure and item number, verify that the item is the one you are looking for, then locate the item number in the repair parts list for the figure.

**F-7. ABBREVIATIONS.** Abbreviations used in this manual are listed in MIL-STD-12.

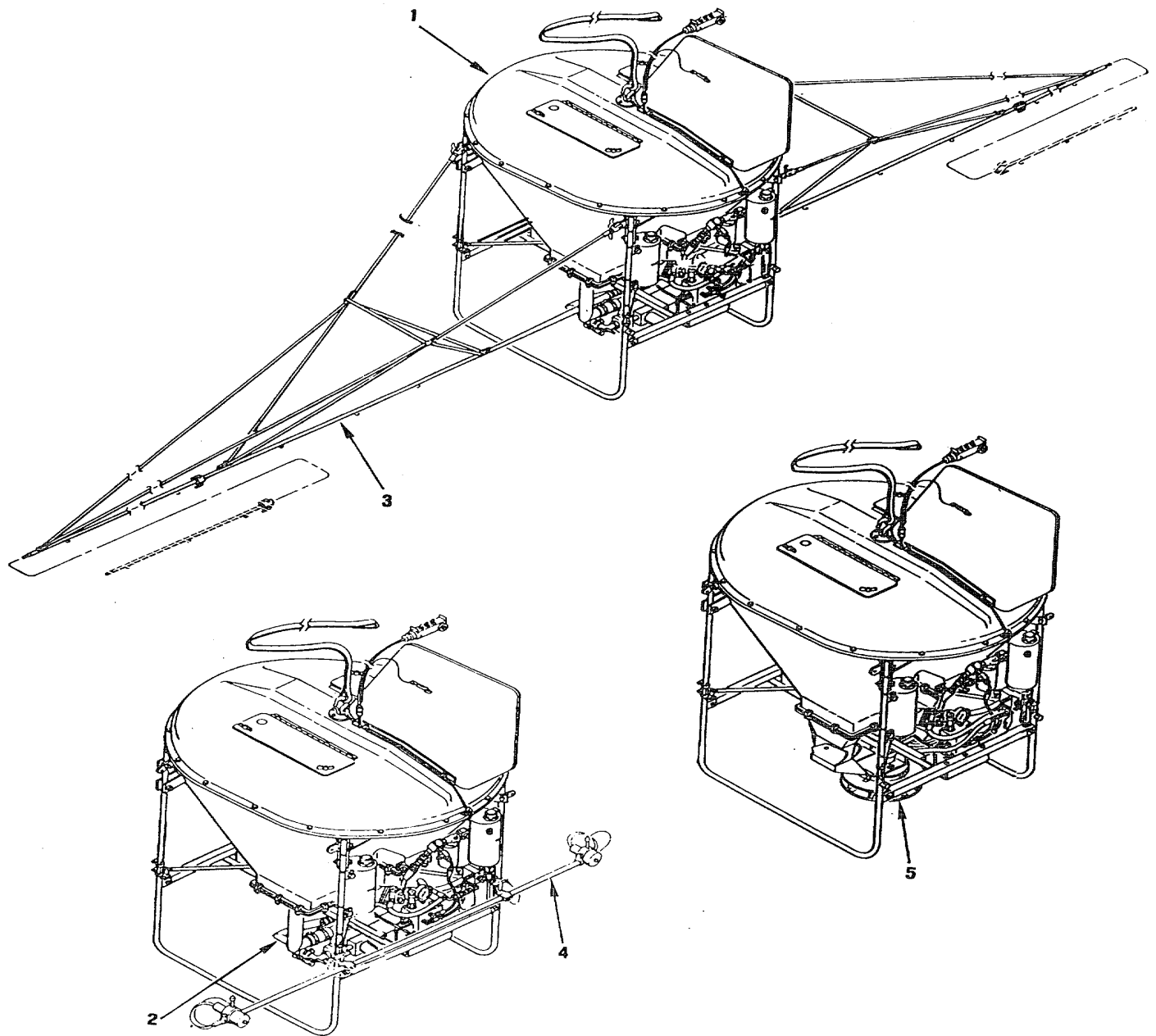

Figure F-1. Pesticide Dispersal Unit

Change 1 (F-7 blank)/F-8

SECTION II				(5)	(6)
(1) ITEM NO	(2) SMR CODE	(3) CAGEC	(4) PART NUMBER	DESCRIPTION AND USABLE ON CODES(UOC)	QTY
GROUP 01 PESTICIDE DISPERSAL UNIT					
FIG. 1 PESTICIDE DISPERSAL UNIT					
1	XBOFF	53945	96801	BUCKET ASSY SEE FIG 2 FOR BREAKDOWN.	1
2	XBOFF	53945	96714	.PUMP & CROSSTUBE SEE FIG 16 FOR..... BREAKDOWN.....	1
3	XBOOO	53945	96821	O/B,BOOM ASSY/LIQ SEE FIG 19 FOR ..... BREAKDOWN.....	1
4	XBOOO	53945	96710	ULV BOOM ASSY SEE FIG 21 FOR..... BREAKDOWN.....	1
5	XBOFF	53945	96830	SLINGER/HOPPER ASSY SEE FIGS. 23, ..... 24, 25 AND 26 FOR BREAKDOWN.....	1

END OF FIGURE



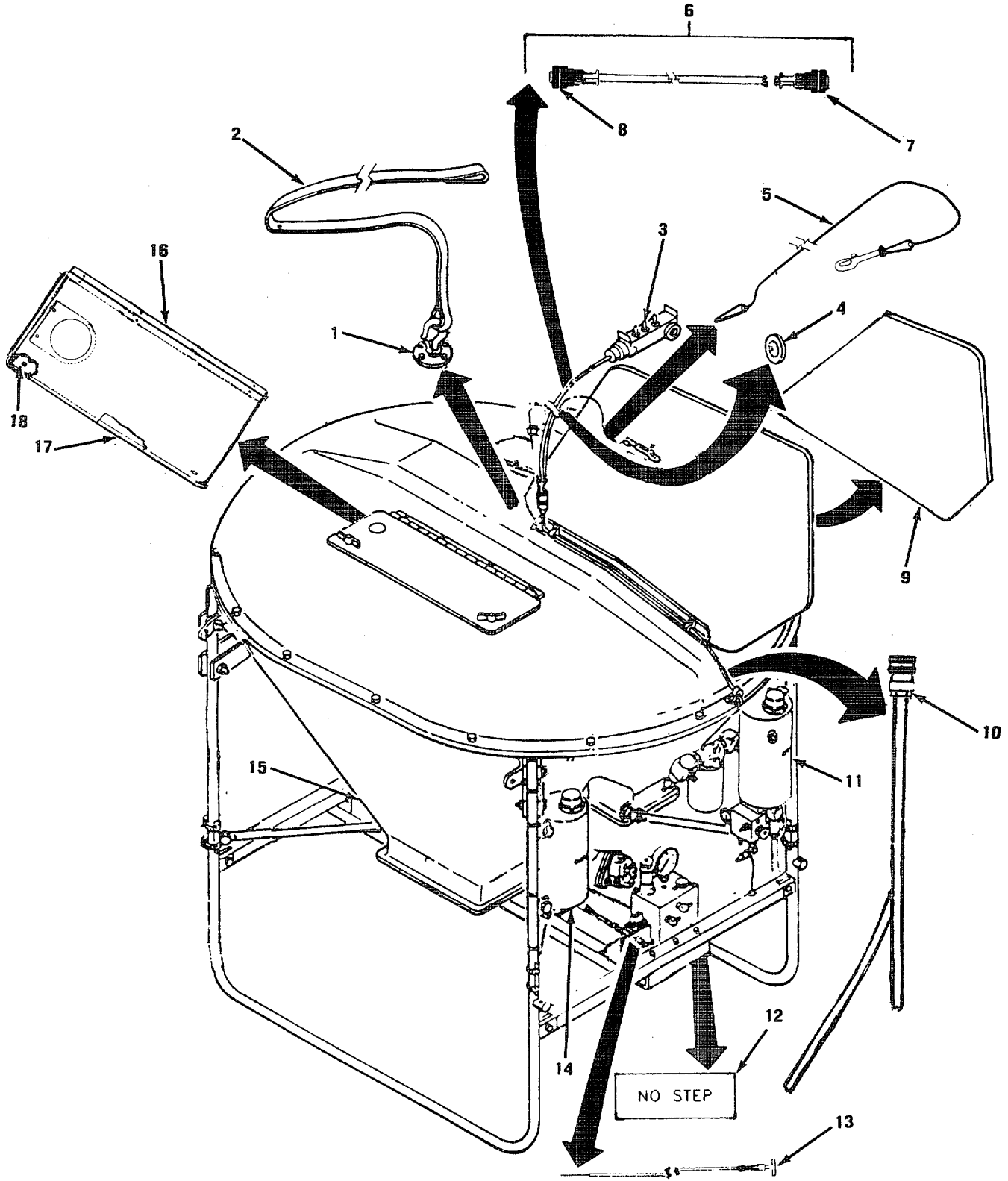

Figure F- 2. Bucket Assembly

F-10 Change 1

SECTION II					
(1)	(2)	(3)	(4)	(5)	(6)
ITEM	SMR		PART		
NO	CODE	CAGEC	NUMBER	DESCRIPTION AND USABLE ON CODES(UOC)	QTY
GROUP 01 PESTICIDE DISPERSAL UNIT					
FIG. 2 BUCKET ASSEMBLY					
1	XBOZZ	53945	102900	SLING LOCK,HOOK.....	1
2	PAOZZ	53945	6679	..STRAP,WEBBING .....	1
3	PAOFZ	53945	6670	. CONTROL-INDICATOR SEE FIG 15 FOR .....	1
				BREAKDOWN.....	
4	XBOZZ	53945	107540	.. TIE,CABLE.....	8
5	PAOZZ	53945	6730	..WIREROPE ASSEMBLY,.....	1
6	XBOZZ	53945	6628	..CABLE ASSY.....	1
7	XBOZZ	96906	MS3106A20-33S	...CONNECTOR .....	1
8	XAOZZ	96906	MS3101A20-33P	...CONNECTOR .....	1
9	XBOZZ	53945	6089	..FIN,TAIL.....	1
10	XDOZZ	53945	6122	..BUCKET HARNESS.....	1
11	XDOFF	53945	96781	..HYD RSVR/MANF ASSY SEE FIG 5 AND .....	1
				10 FOR BREAKDOWN.....	
12	XDOZZ	53945	156110	..STICKER,NO-STEP .....	2
13	PAOZZ	53945	6602	..CONTROL ASSEMBLY,PU .....	1
14	XDOOO	53945	96771	..TANK ASSY,FUEL SEE FIG 6 FOR .....	1
				BREAKDOWN.....	
15	XDOFF	53945	96808	..BATTERY/HYD ASSY SEE FIG 13 FOR .....	1
				BREAKDOWN.....	
16	XDOOO	53945	96806	..DOOR,LID ASSY .....	2
17	XBOZZ	53945	6641	...GASKET,LID .....	2
18	XDOZZ	72794	GP5	... GROMMET,NONMETALLIC.....	4

END OF FIGURE

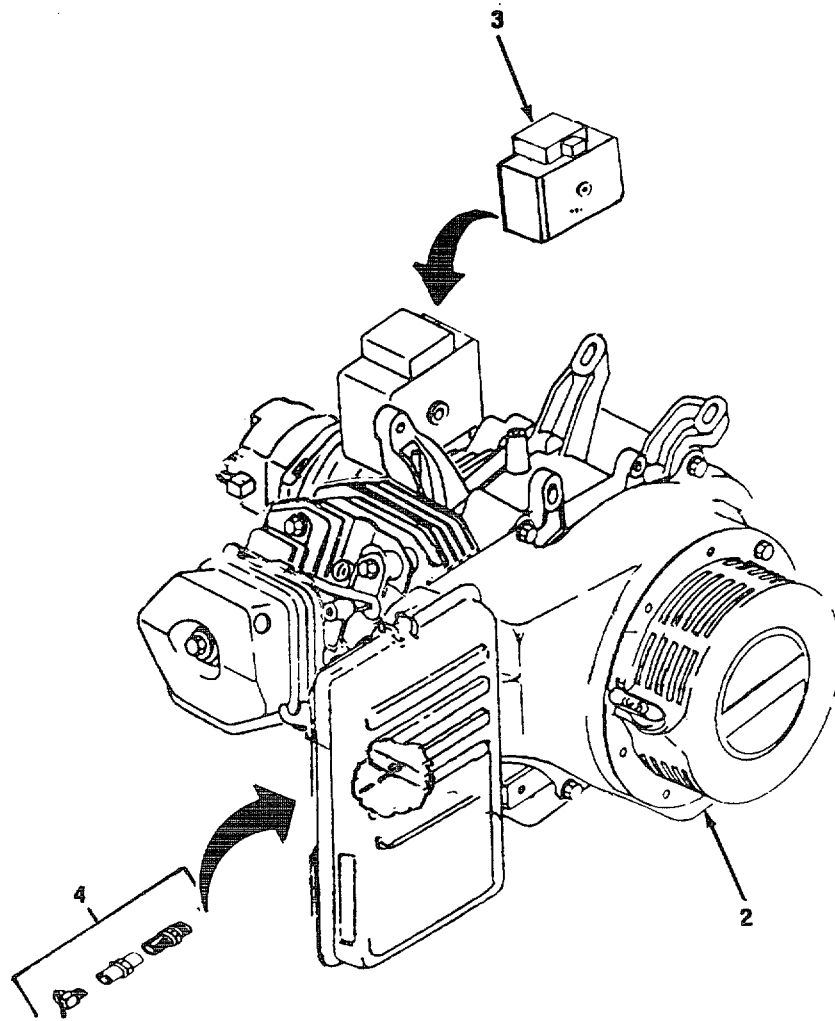
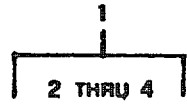

Figure F-3. Engine and Pump Assembly

F-12 Change 1

SECTION II

(1) ITEM NO	(2) SMR CODE	(3) CAGEC	(4) PART NUMBER	(5) DESCRIPTION AND USABLE ON CODES(UOC)	(6) QTY
GROUP 01 PESTICIDE DISPERSAL UNIT					
FIG. 3 ENGINE AND PUMP ASSEMBLY					
1	XDOFF	53945	96724	.ENGINE & PUMP ASSY .....	1
2	XBOFF	53945	94647	..ENGINE,MODIFIED .....	1
3	XBOFF	53945	6124	..KEY SW BOX ASSY .....	1
4	XBOZZ	53945	DC607-4	..DRAIN COCK .....	1

END OF FIGURE

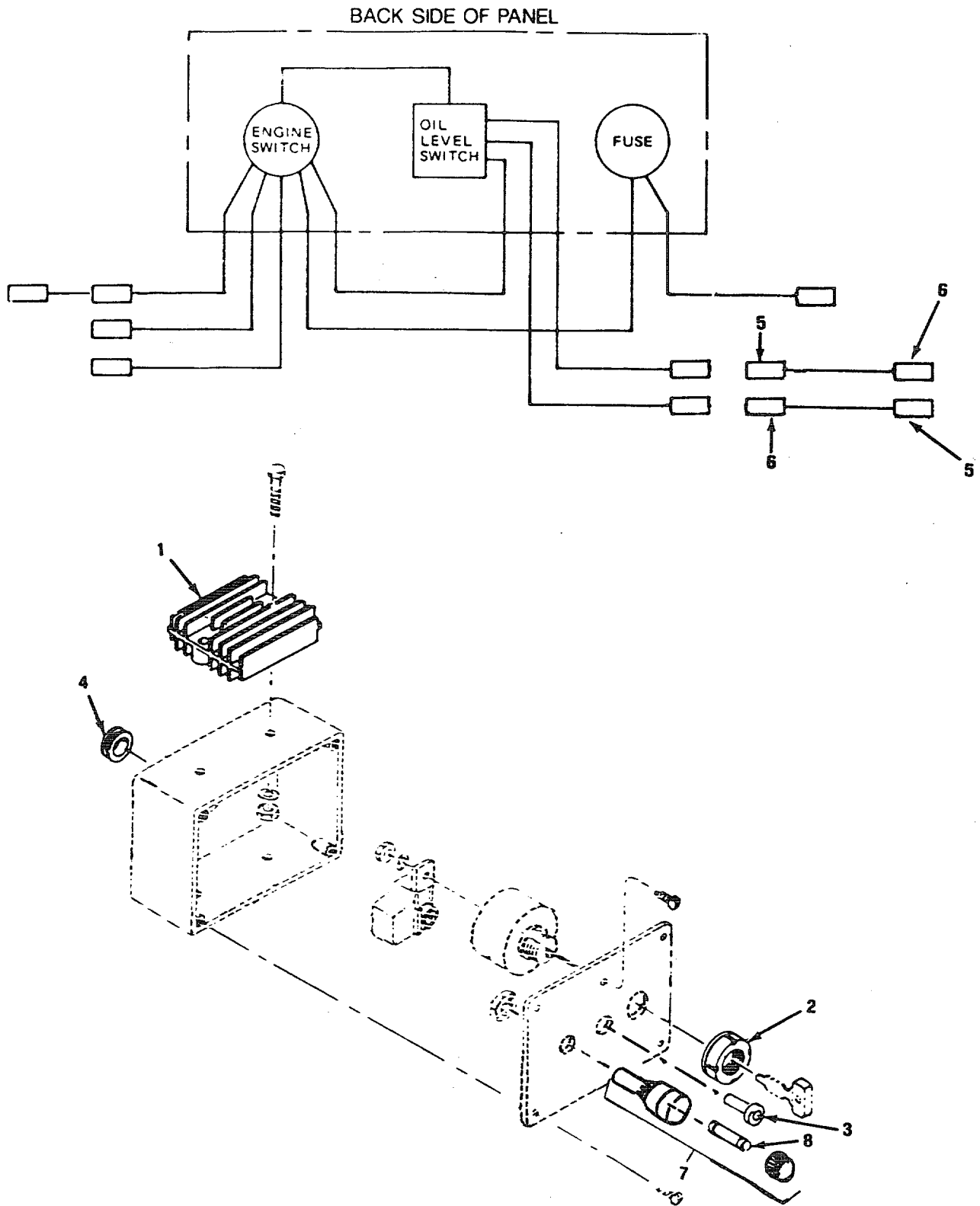

Figure F-4. Key Switchbox Assembly

SECTION II

(1) ITEM NO	(2) SMR CODE	(3) CAGEC	(4) PART NUMBER	(5) DESCRIPTION AND USABLE ON CODES(UOC)	(6) QTY
GROUP 01 PESTICIDE DISPERSAL UNIT					
FIG. 4 KEY SWITCHBOX ASSEMBLY					
1	XBFZZ	53945	6114	.. RECTIFIER ASSEMBLY.....	1
2	XBFZZ	53945	6117	...SWITCH,ENGINE KEY .....	1
3	PBFZZ	53945	6118	.. .SWITCH,PRESSURE.....	1
4	XBFZZ	70485	452	... GROMMET .....	1
5	XBFZZ	2V131	82F-157-NBL	...RECEPTACLE,FEMALE.....	2
6	XBFZZ	2V131	82M-157-NB	...PLUG,SNAP,MALE .....	2
7	XBFZZ	71400	342	...FUSEHOLDER .....	1
8	PBOZZ	81349	F02A32V15A	...FUSE,CARTRIDGE .....	1

END OF FIGURE

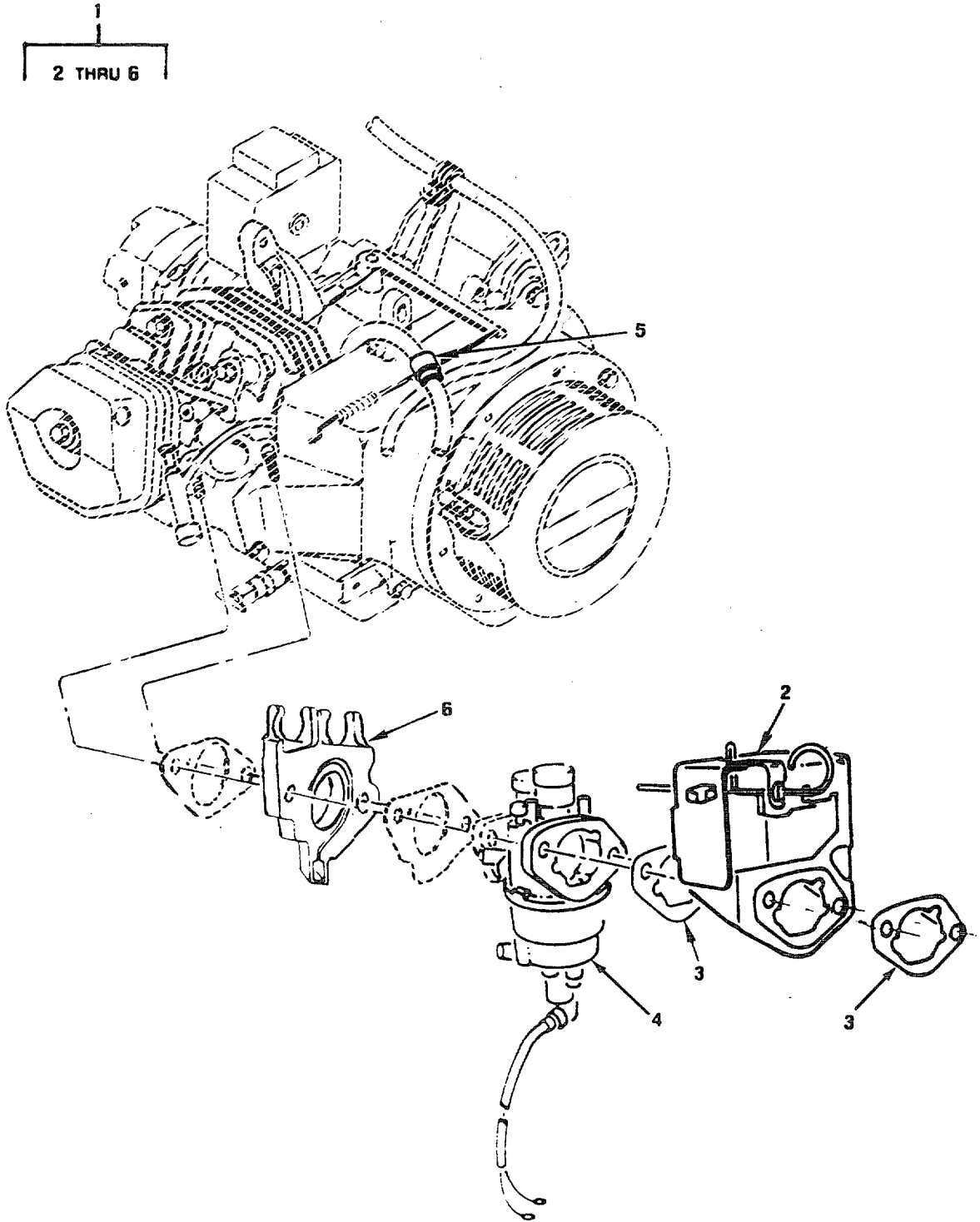

Figure F- 5. Carburetor Assembly

F-16 Change 1

SECTION II

(1) ITEM NO	(2) SMR CODE	(3) CAGEC	(4) PART NUMBER	(5) DESCRIPTION AND USABLE ON CODES(UOC)	(6) QTY
GROUP 01 PESTICIDE DISPERSAL UNIT					
FIG. 5 CARBURETOR ASSEMBLY					
1	PAOFZ	53945	7136	...CARBURETOR,FLOAT .....	1
2	XBFZZ	53945	123536	....STAY ASSY,SOLENOID .....	1
3	XBFZZ	53945	123538	... .GASKET.....	2
4	XBFZZ	53945	123522	....CHOKE,CARB ASSY .....	1
5	XBFZZ	53945	123539	.... VALVE,CHECK,DASHPOT.....	1
6	XBFZZ	53945	123541	.... INSULATOR,CARB .....	1

END OF FIGURE



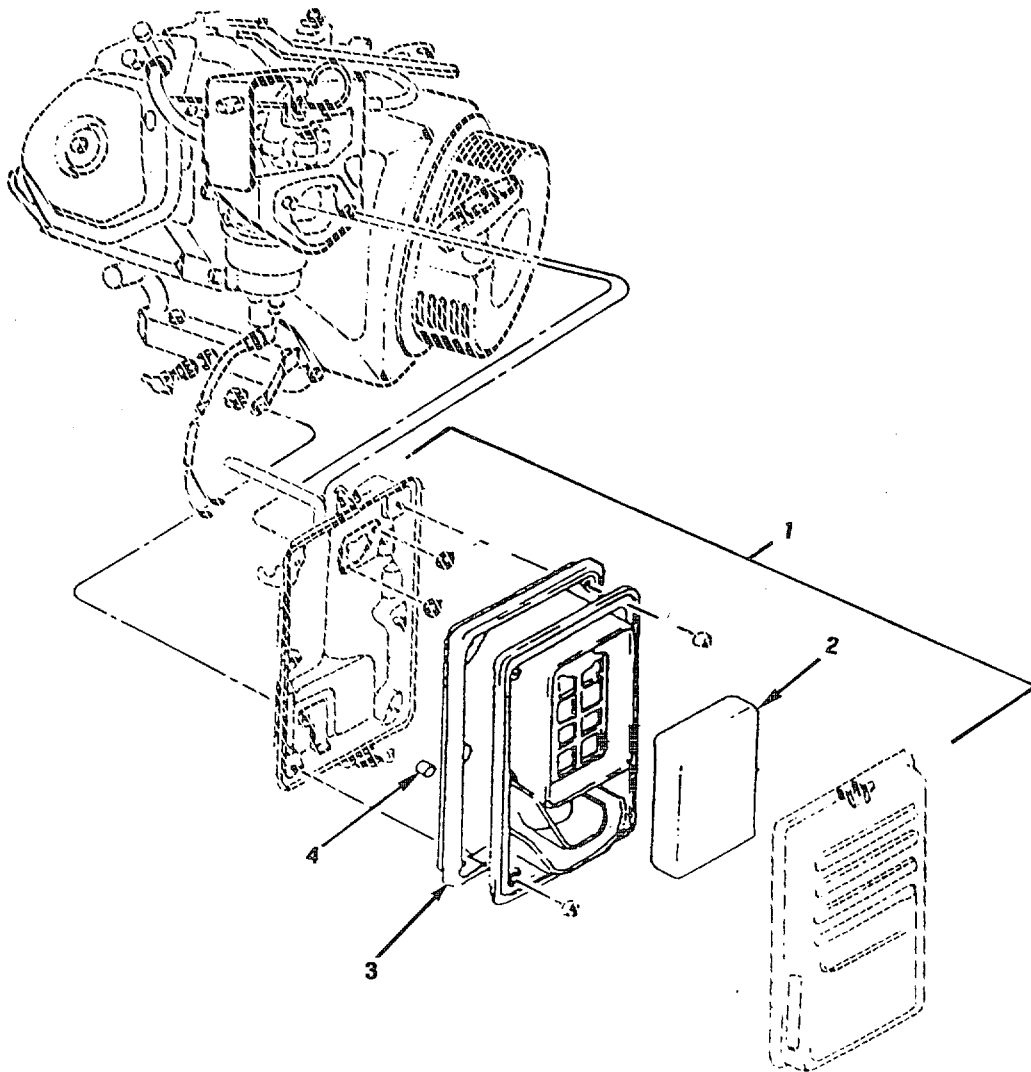

Figure F-6. Air Cleaner

F-18 Change 1

SECTION II

(1)	(2)	(3)	(4)	(5)	(6)
ITEM	SMR		PART		
NO	CODE	CAGEC	NUMBER	DESCRIPTION AND USABLE ON CODES(UOC)	QTY

GROUP 01 PESTICIDE DISPERSAL UNIT

FIG. 6 AIR CLEANER

FIG.

1	XBOOO	53945	7149	...AIR CLEANER ASSY .....	1
2	PAOZZ	52905	123525	...FILTER ELEMENT,INTA .....	1
3	PAOZZ	52905	123532	...GASKET.....	1
4	PAOZZ	52905	123533	...TUBING,NONMETALLIC .....	1

END OF FIGURE

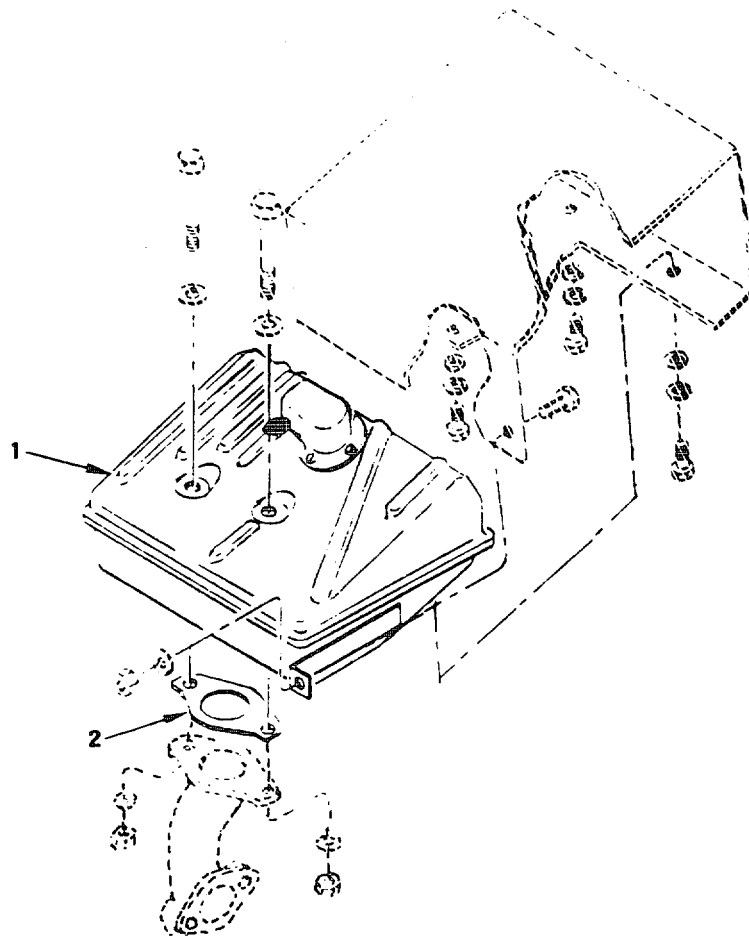
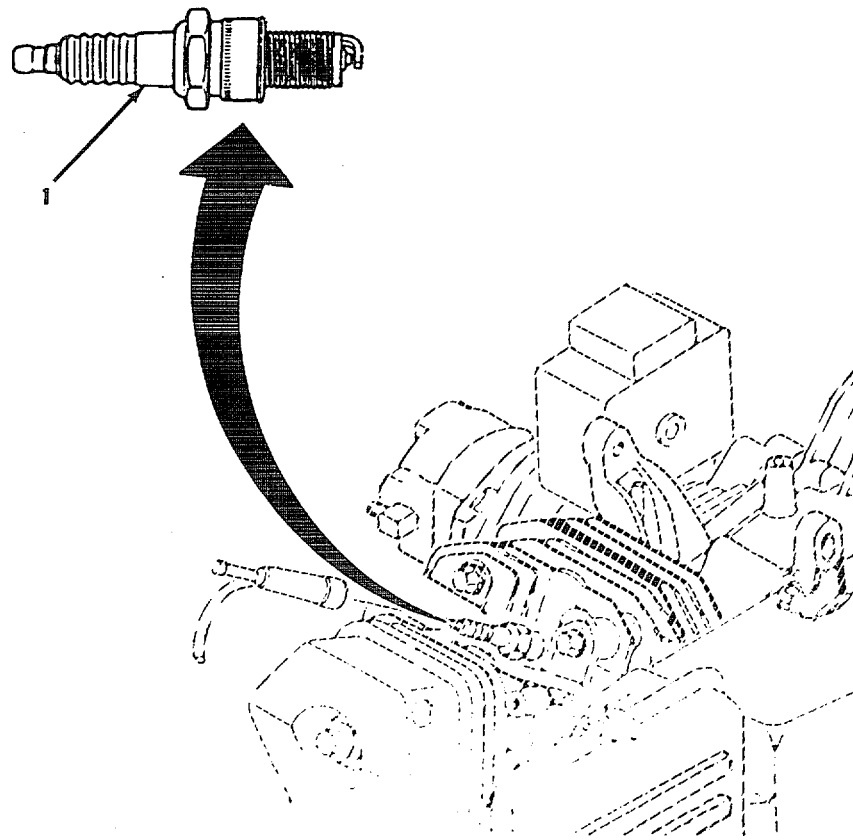

Figure F-7. Muffler Assembly

F-20 Change 1

SECTION II				(5)	(6)
(1)	(2)	(3)	(4)		
ITEM	SMR		PART	DESCRIPTION AND USABLE ON CODES(UOC)	QTY
NO	CODE	CAGEC	NUMBER		
				GROUP 01 PESTICIDE DISPERSAL UNIT	
				FIG. 7 MUFFLER ASSEMBLY	
1	XBOOO	53945	96603	...MUFFLER ASSY .....	1
2	XBOZZ	53945	6601	....GASKET,MUFFLER .....	1

END OF FIGURE



**Figure F-8. Spark Plug**

**F-22 Change 1**

SECTION II

(1) ITEM NO	(2) SMR CODE	(3) CAGEC	(4) PART NUMBER	(5) DESCRIPTION AND USABLE ON CODES(UOC)	(6) QTY
-------------------	--------------------	--------------	-----------------------	---	------------

GROUP 01 PESTICIDE DISPERSAL UNIT

FIG. 8 SPARK PLUG

1	PAOZZ	52970 64		....SPARK PLUG .....	1
---	-------	----------	--	----------------------	---

END OF FIGURE

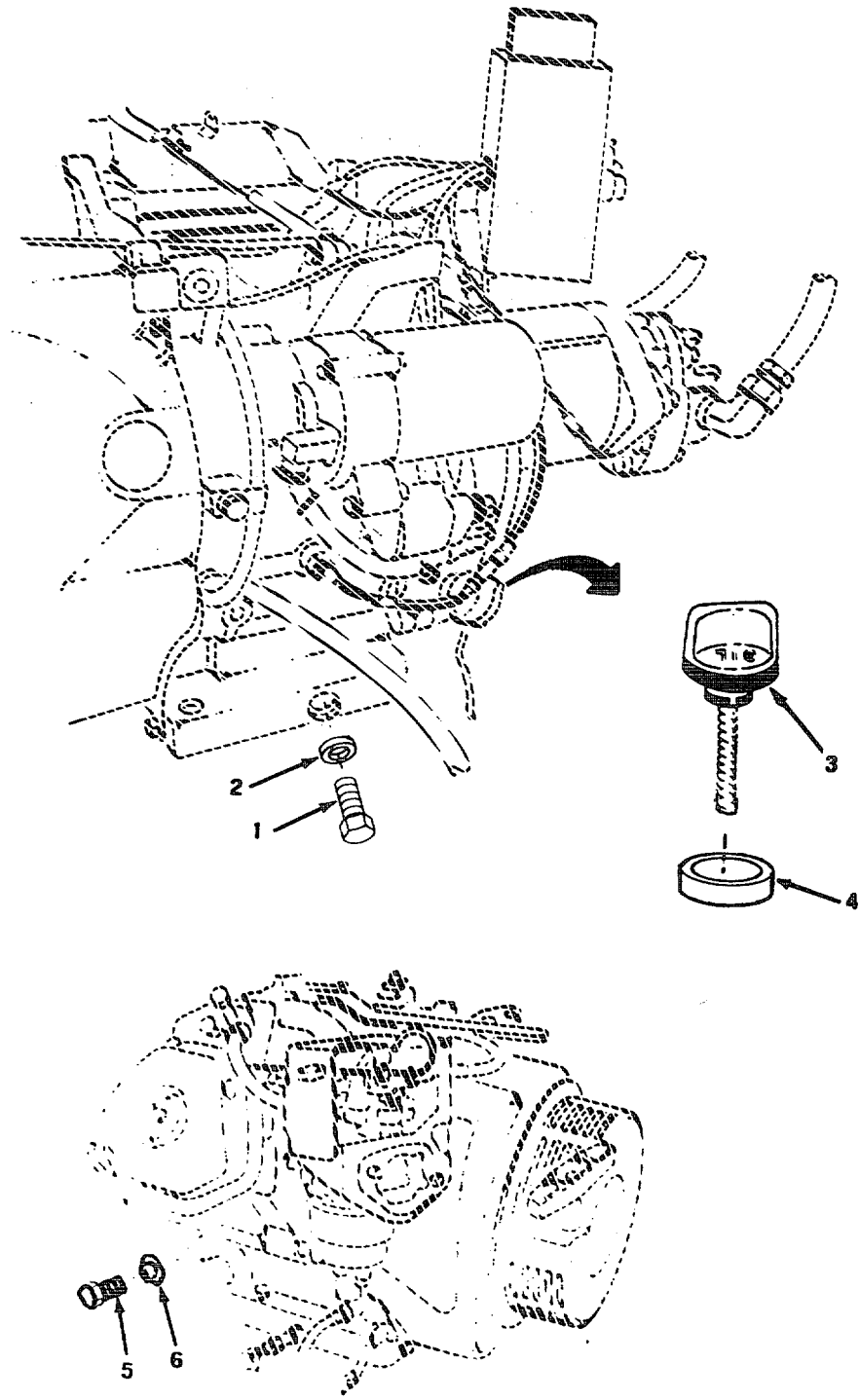

Figure F-9. Oil Fill and Drain Assembly

F-24 Change 1

SECTION II

TM 5-3740-218-13&P

(1) ITEM NO	(2) SMR CODE	(3) CAGEC	(4) PART NUMBER	(5) DESCRIPTION AND USABLE ON CODES(UOC)	(6) QTY
-------------------	--------------------	--------------	-----------------------	---	------------

GROUP 01 PESTICIDE DISPERSAL UNIT

FIG. 9 OIL FILL AND DRAIN ASSEMBLY

1	XBOZZ	53945	123556	PLUG, DRAIN .....	2
2	XBOZZ	53945	123555	WASHER, DRAIN PLUG .....	2
3	XBOZZ	53945	123557	CAP, OIL FILLER .....	1
4	XAOZZ	53945	15625-ZE1-000	GASKET, OIL CAP .....	1
5	XBOZZ	53945	123558	CAP, OIL HOLE .....	1
6	XBOZZ	53945	123559	GASKET, OIL CAP .....	1

END OF FIGURE



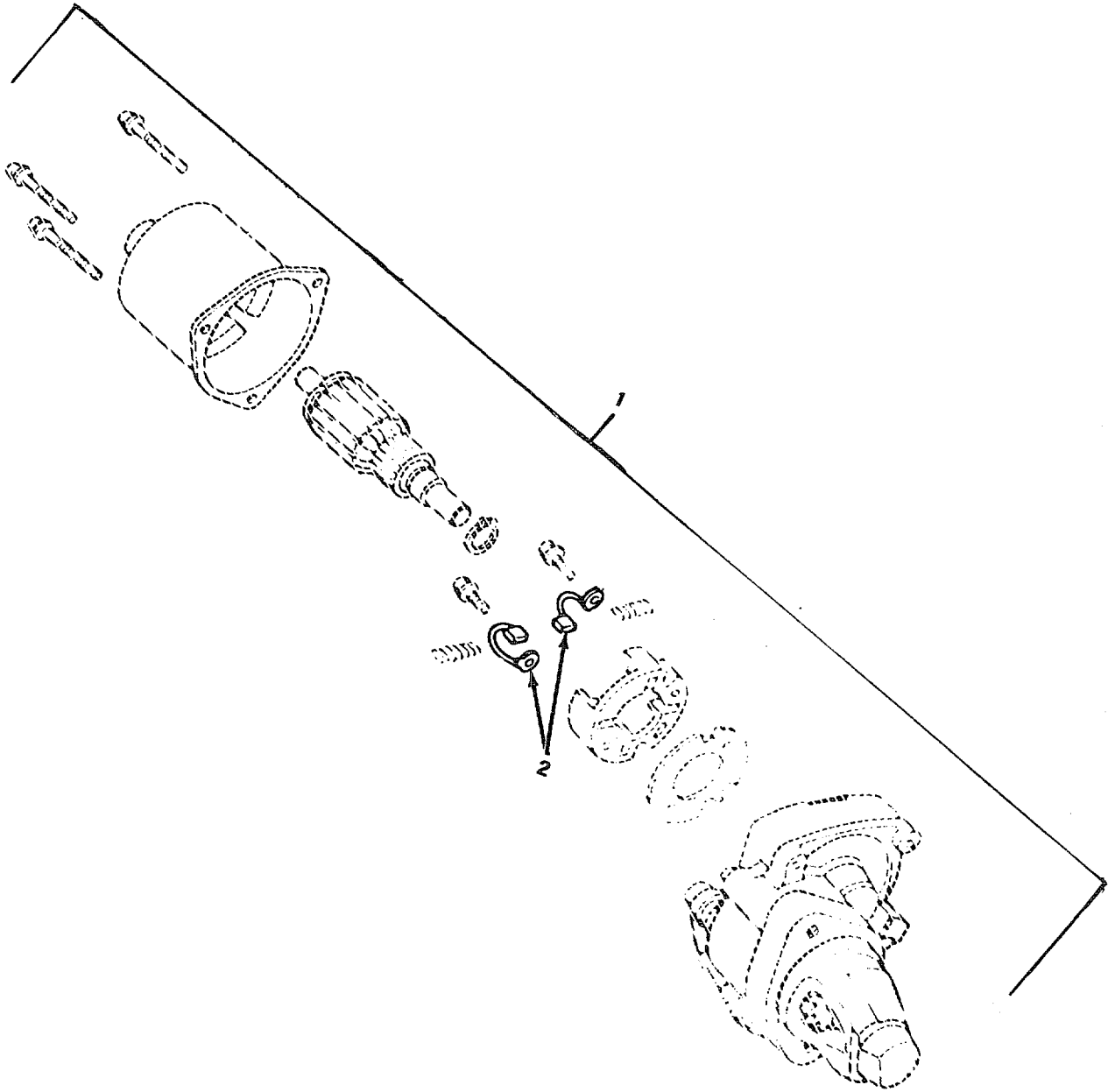

Figure F-10. Starter Motor

Change 1

F-26

SECTION II TM 5-3740-218-13&P

(1) ITEM NO	(2) SMR CODE	(3) CAGEC	(4) PART NUMBER	(5) DESCRIPTION AND USABLE ON CODES(UOC)	(6) QTY
-------------------	--------------------	--------------	-----------------------	---	------------

GROUP 01 PESTICIDE DISPERSAL UNIT

FIG. 10 STARTER MOTOR

1	PAOFZ	S0208	31210-ZE3-013	STARTER, ENGINE, ELEC .....	1
2	XBFZZ	53945	123562	BRUSH, STARTER .....	1

END OF FIGURE

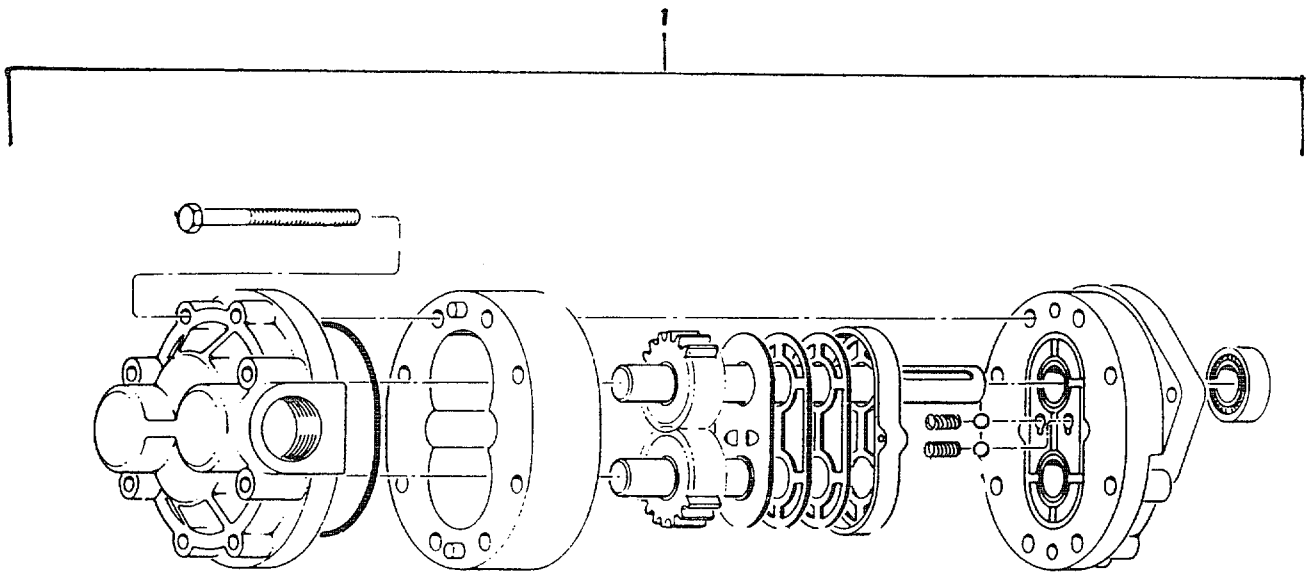

Figure F-11. Hydraulic Pump Assembly

SECTION II TM 5-3740-218-13&P

(1)	(2)	(3)	(4)	(5)	(6)
ITEM	SMR	CAGEC	PART	DESCRIPTION AND USABLE ON CODES(UOC)	QTY
NO	CODE		NUMBER		

GROUP 01 PESTICIDE DISPERSAL UNIT

FIG. 11 HYDRAULIC PUMP ASSEMBLY

1	PAOFZ	12008	B24303-RBAJ	PUMP, ROTARY .....	1
	XBOZZ	12008	24300-902	PARTS REPAIR KIT .....	1

END OF FIGURE

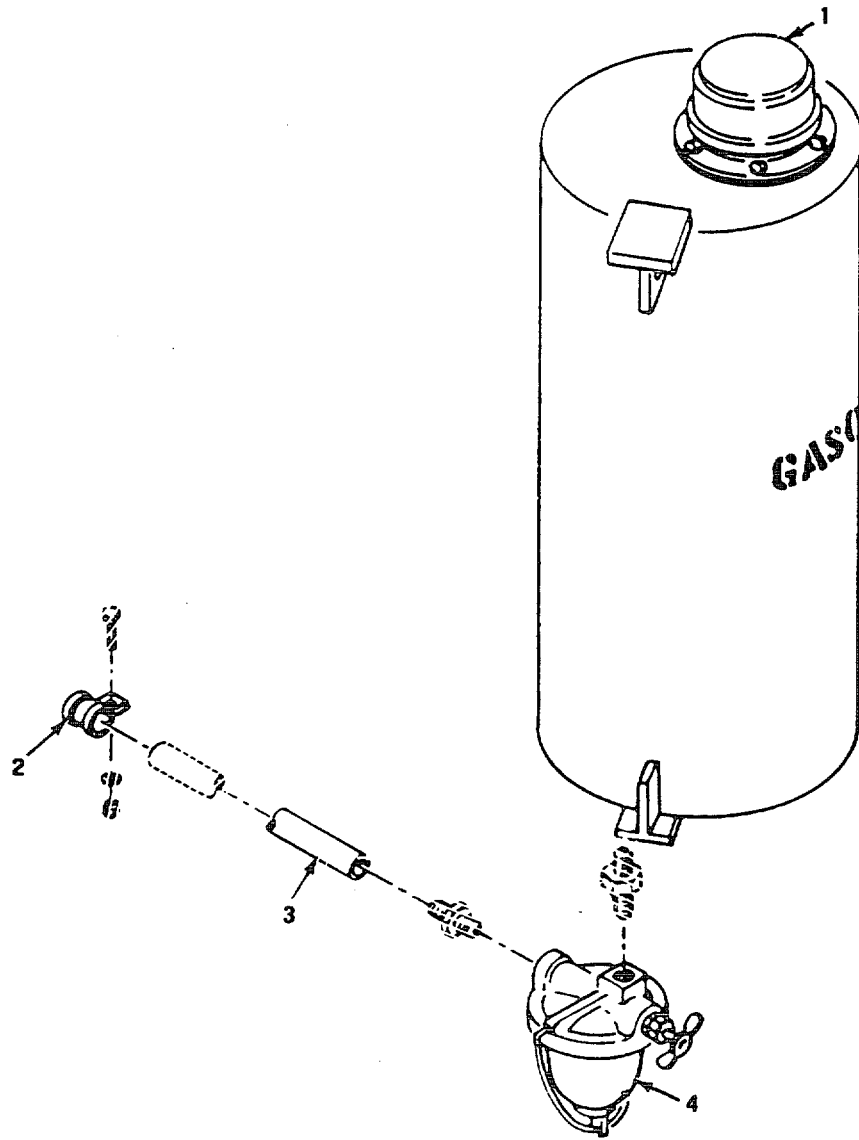

Figure F-12. Gas Tank Assembly

SECTION II

TM 5-3740-218-13&P

(1) ITEM NO	(2) SMR CODE	(3) CAGEC	(4) PART NUMBER	(5) DESCRIPTION AND USABLE ON CODES(UOC)	(6) QTY
GROUP 01 PESTICIDE DISPERSAL UNIT					
FIG. 12 GAS TANK ASSEMBLY					
1	XBOZZ	55524	AB10103	FILLER, BREATHER .....	1
2	XBOZZ	96906	MS21919WD68	CLAMP, HOSE .....	1
3	XBOZZ	53945	126005	HOSE, PUSH-ON .....	1
4	PAOZZ	30327	192J	STRAINER, SEDIMENT .....	1

END OF FIGURE

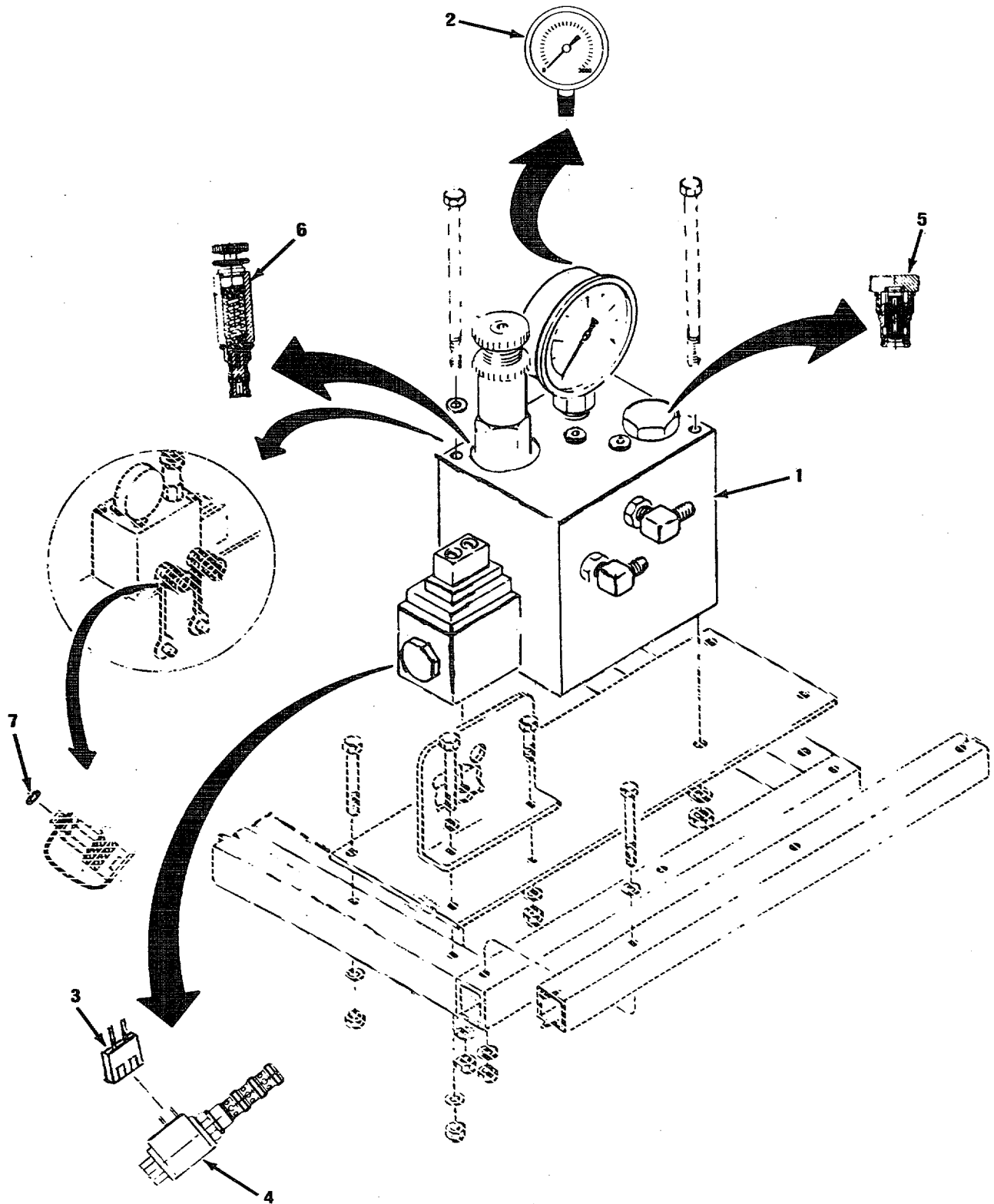

Figure F-13. Battery/Hydraulic Assembly (Sheet 1 of 2)

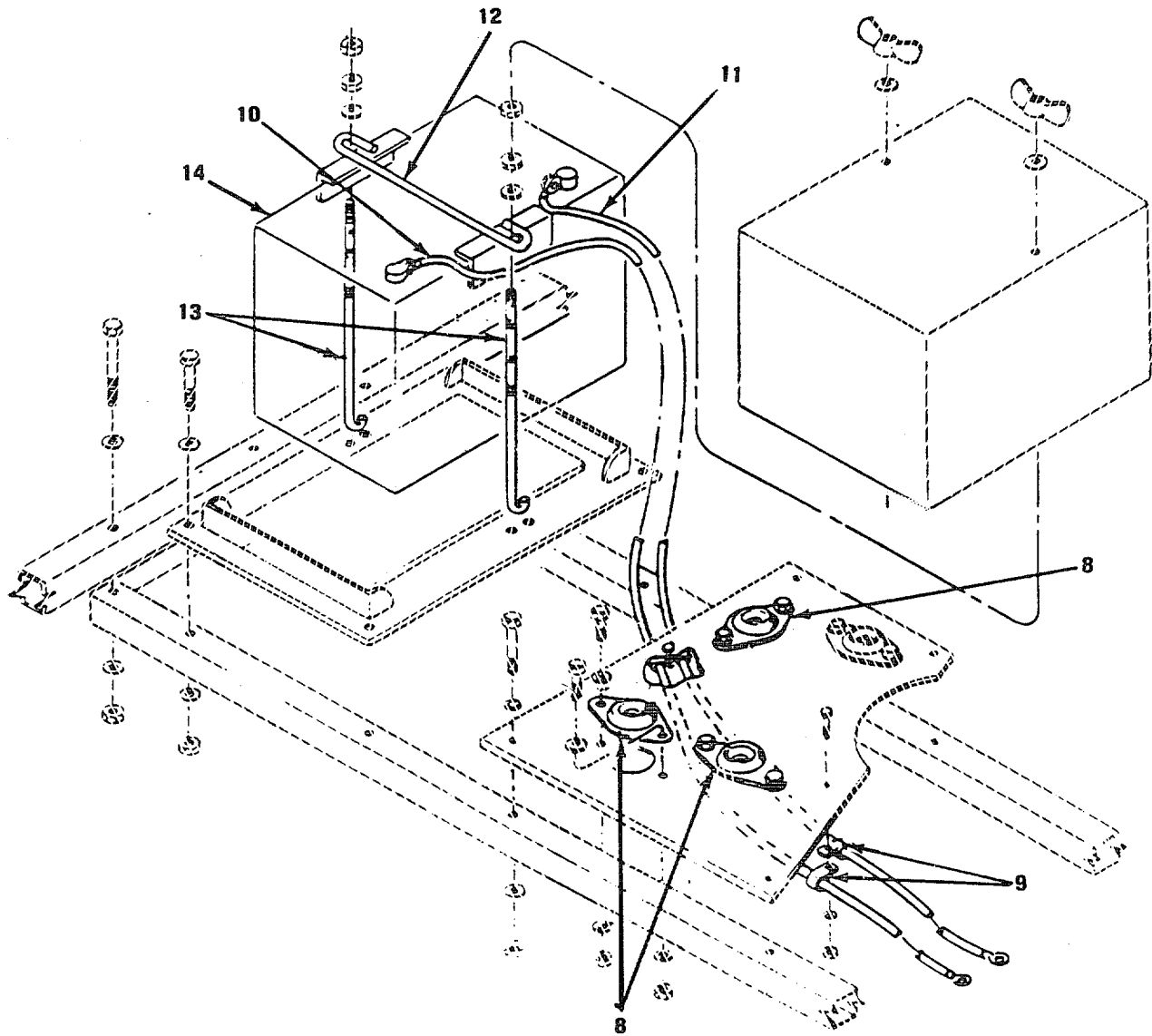

Figure F-13. Battery/Hydraulic Assembly (Sheet 2 of 2)



SECTION II

TM 5-3740-218-13&P

(1) ITEM NO	(2) SMR CODE	(3) CAGEC	(4) PART NUMBER	(5) DESCRIPTION AND USABLE ON CODES(UOC)	(6) QTY
GROUP 01 PESTICIDE DISPERSAL UNIT					
FIG. 13 BATTERY/HYDRAULIC ASSEMBLY					
	XCOOO	53945	6802	.BASIC HYD, SCHEMATIC .....	1
1	PBOFZ	52905	6837	..BLOCK ASSEMBLY, HYDR .....	1
2	XBFZZ	53945	125100	.. .GAUGE, PRESSURE .....	1
3	PBFZZ	52905	152748	...COIL, ELECTRICAL .....	1
4	PBFFZ	53945	152753	... VALVE, SOLENOID .....	1
5	XBFZZ	53945	152755	...VALVE, CHECK .....	1
6	XBFFF	53945	152754	.. .VALVE, PRESSURE .....	1
7	XBFZZ	02697	2-011-V747-75	... O-RING .....	4
8	XBOZZ	81860	505-3-NS	..ISOLATOR, ALL-ANGLE .....	4
9	XBOZZ	96906	MS21919WDG6	..CLAMP, LOOP .....	4
10	XBOZZ	53945	6109	..CABLE, BATTERY, POS .....	1
11	XBOZZ	53945	6111	..CABLE, BATTERY, NEG .....	1
12	XBOZZ	6V397	BHCP	..CROSS BAR, HOLD-DOWN .....	1
13	XBOZZ	6V397	BHB121-J	..BOLT, HOLD-DOWN .....	2
14	PBOZZ	53945	107745	..BATTERY, STORAGE .....	1
	PAFZZ	52905	152757	...PARTS KIT, SOLENOID .....	1
	PAFZZ	53945	152756	...PARTS KIT, SAFETY RE .....	1

END OF FIGURE

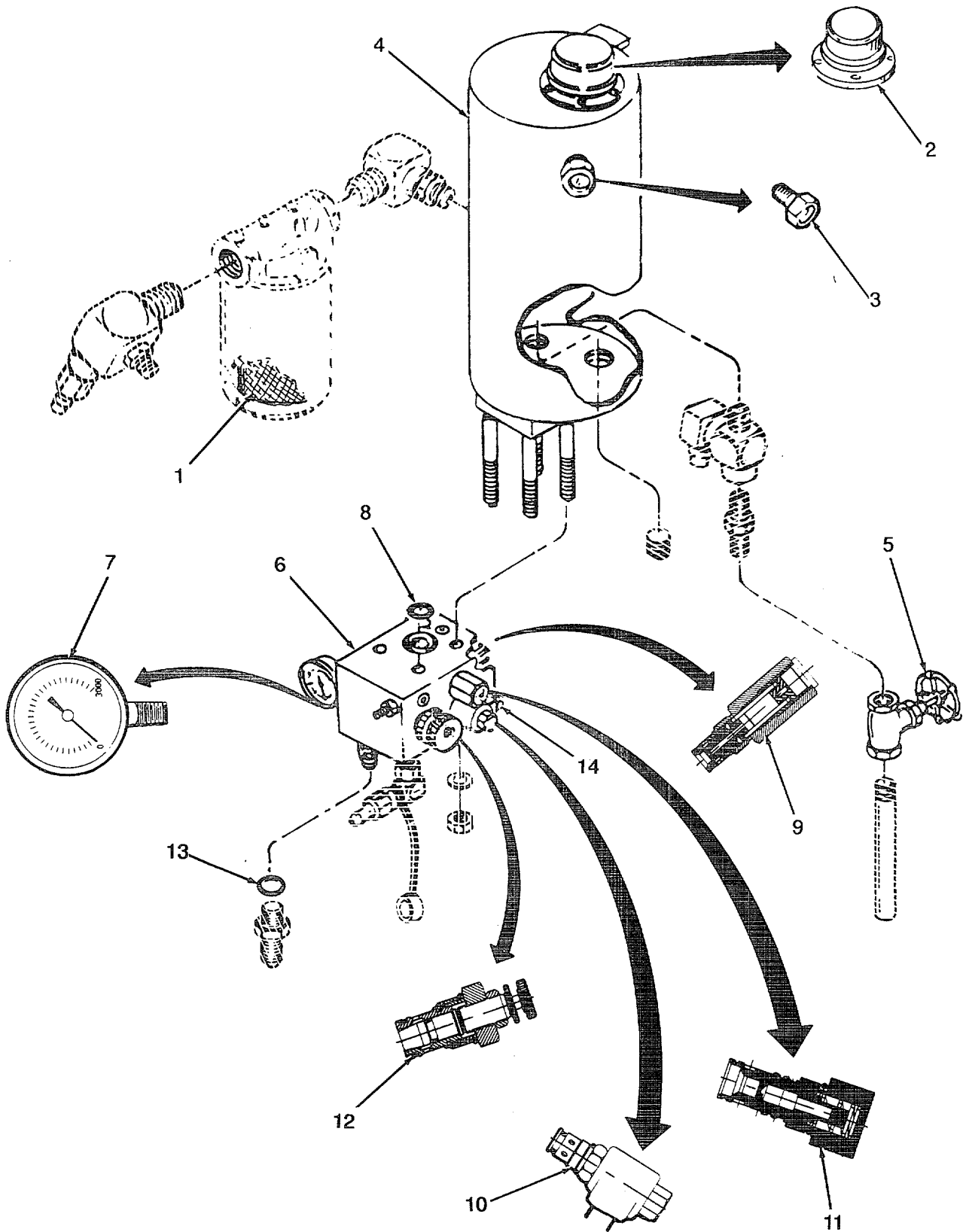

Figure F-14. Hydraulic Reservoir and Primer Manifold Assembly

SECTION II

TM 5-3740-218-13&P

(1) ITEM NO	(2) SMR CODE	(3) CAGEC	(4) PART NUMBER	(5) DESCRIPTION AND USABLE ON CODES(UOC)	(6) QTY
GROUP 01 PESTICIDE DISPERSAL UNIT					
FIG. 14 HYDRAULIC RESERVOIR AND PRIMARY MANIFOLD ASSEMBLY					
1	PAOZZ	02249	K22001	..FILTER ELEMENT, FLUI .....	1
2	XBOZZ	12008	AB1O10-3(F-EZY)	..FILLER, BREATHER .....	1
3	XDOZZ	12008	L5P151-5	..SIGHT GAUGE, RSVR .....	1
4	XDOZZ	53945	96780	..RESERVOIR, HYD .....	1
5	XBOZZ	53945	152210	..GATE VALVE, BRASS .....	1
6	PBOFF	53945	5758	..MANIFOLD ASSEMBLY, H .....	1
7	XBFZZ	53945	4622	...GAUGE, PRESSURE .....	1
8	XBFZZ	02697	2-121 V747-75	... O-RING .....	1
9	PBFFZ	53945	152762	...VALVE, SAFETY RELIEF .....	1
10	PBFFF	53945	152764	...VALVE, SOLENOID .....	1
11	PBFFF	53945	152763	...VALVE, REGULATING, FL .....	1
12	PBFZZ	53945	152765	...VALVE, GLOBE .....	1
13	XBOZZ	53945	128135	..O-RING .....	1
14	PBOZZ	53945	152771	..COIL, ELECTRICAL .....	1
	XBFZZ	53945	152768	...PARTS REPAIR KIT RELIEF VALVE.. .....	1
	XBFZZ	53945	152767	...PARTS REPAIR KIT SOLENOID VALVE. ....	1
	XBFZZ	53945	152766	... PARTS REPAIR KIT FLOW VALVE .....	1
	XBFZZ	53945	152769	...PARTS REPAIR KIT REPAIR KIT FOR ALL THREE VALVES .....	1

END OF FIGURE

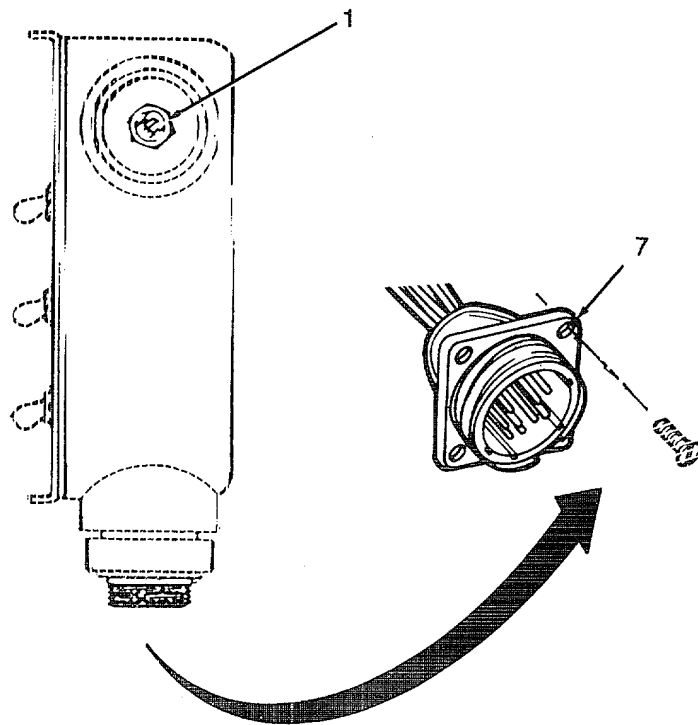
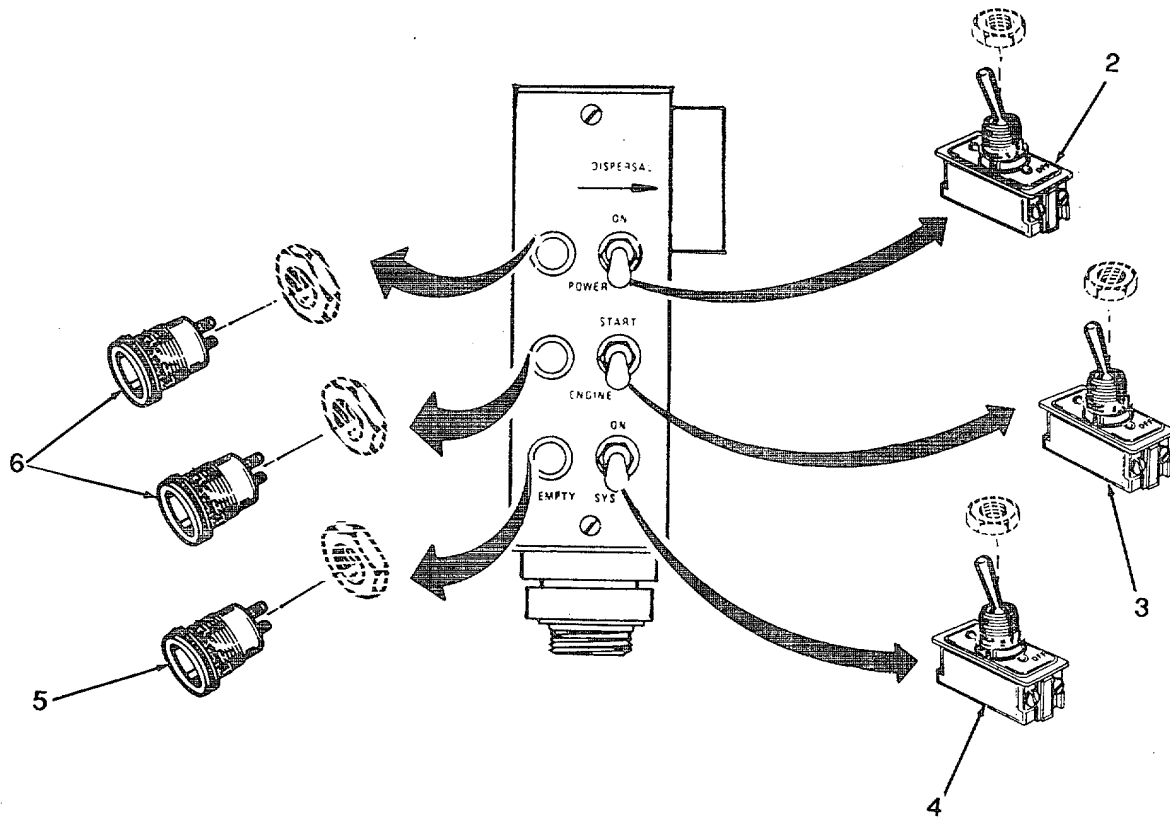

Figure F-15. Hand Control Assembly

SECTION II

TM 5-3740-218-13&P

(1)	(2)	(3)	(4)	(5)	(6)
ITEM	SMR		PART		
NO	CODE	CAGEC	NUMBER	DESCRIPTION AND USABLE ON CODES(UOC)	QTY

GROUP 01 PESTICIDE DISPERSAL UNIT

FIG. 15 HAND CONTROL ASSEMBLY

1	XBFZZ	81640	W301	SWITCH, PUSHBUTTON .....	1
2	XBFZZ	96906	MS25307-232	SWITCH, TOGGLE .....	1
3	XBFZZ	96906	MS25306-262	SWITCH, TOGGLE .....	1
4	XBFZZ	96906	MS25306-222	SWITCH, TOGGLE .....	1
5	XBFZZ	60886	AP2M211-A	LED, YELLOW .....	1
6	XDFZZ	60886	AP2M211-G	LED, GREEN .....	1
7	XDFZZ	96906	MS3452W20-33P	CONNECTOR, RCPT .....	1

END OF FIGURE

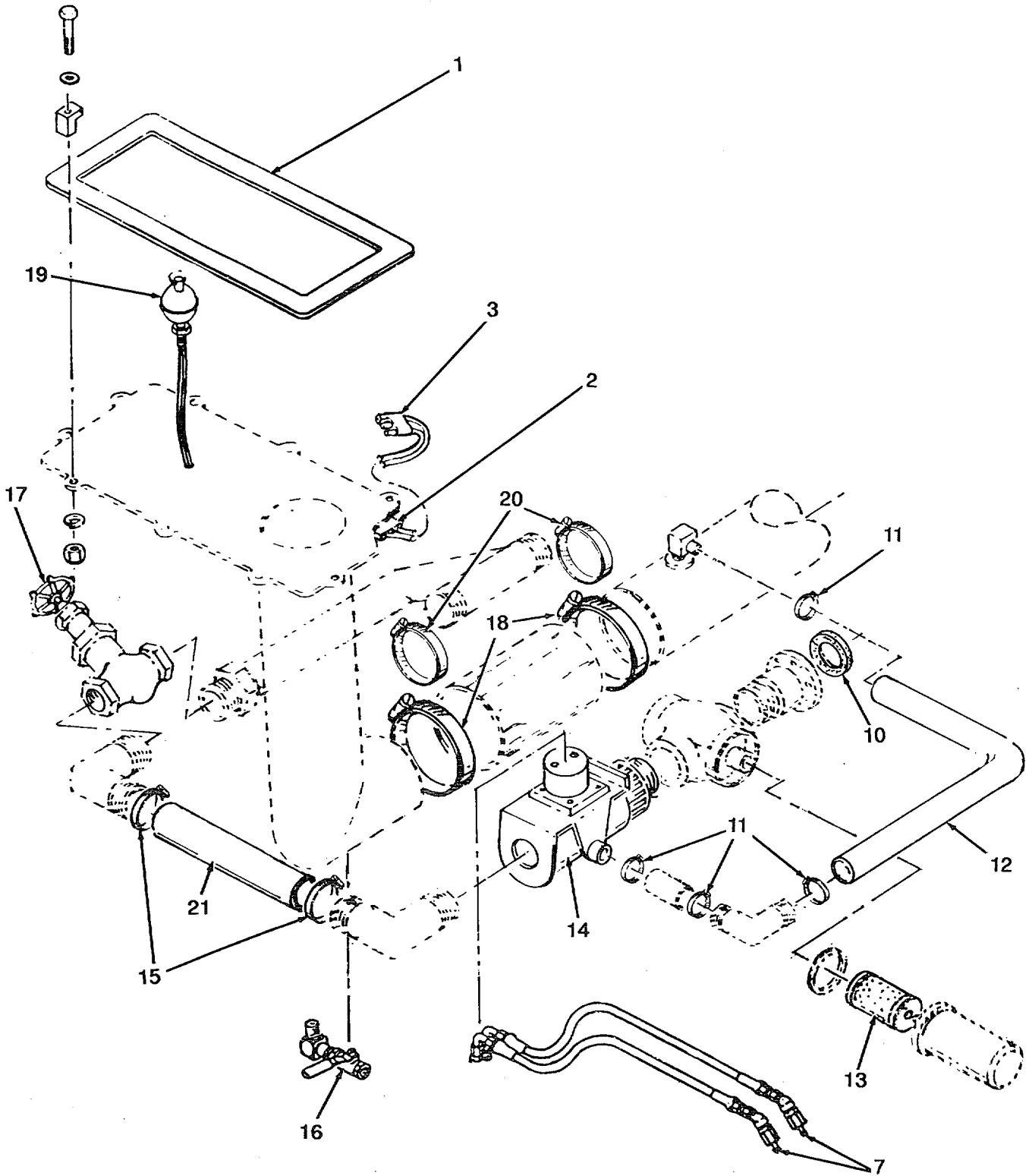

Figure F-16. Pump and Crosstube Assembly (Sheet 1 of 2)

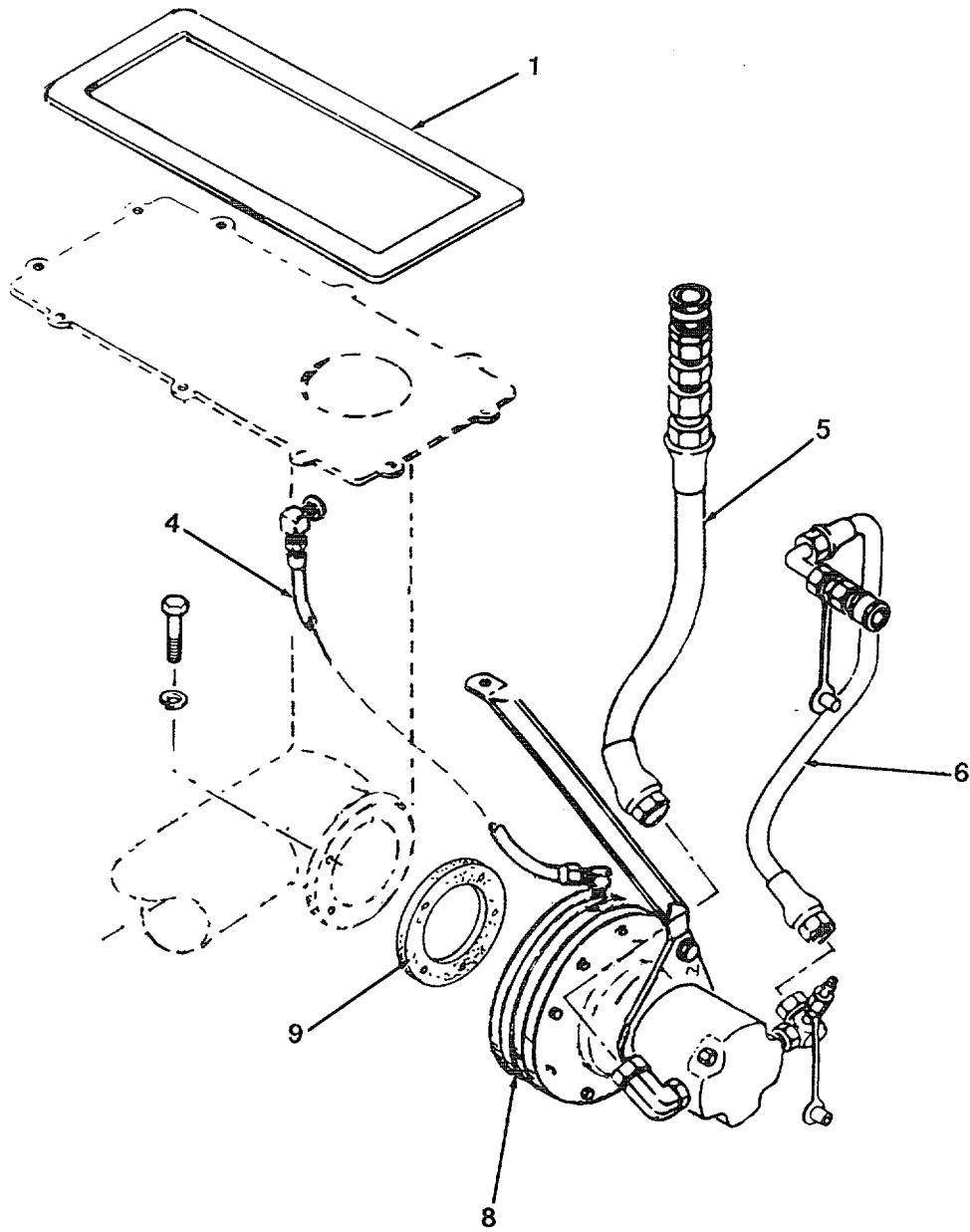

Figure F-16. Pump and Crosstube Assembly (Sheet 2 of 2)

Change 1

F-42

SECTION II

TM 5-3740-218-13&P

(1) ITEM NO	(2) SMR CODE	(3) CAGEC	(4) PART NUMBER	(5) DESCRIPTION AND USABLE ON CODES(UOC)	(6) QTY
GROUP 02 LIQUID DISPERSAL SYSTEM					
FIG. 16 PUMP AND CROSSTUBE ASSEMBLY					
	XCOOO	53945	96812	HYDRAULIC SPRAY SCH .....	1
1	PBOZZ	53945	539	.GASKET .....	2
2	PAOZZ	96906	MS3367-4-9	.STRAP, TIEDOWN, ELECT .....	1
3	PAOZZ	53945	6108	.WIRING HARNESS .....	1
4	PBOZZ	53945	9056	.HOSE ASSEMBLY, NONME .....	1
5	PBOZZ	53945	9811	.HOSE ASSEMBLY, NONME .....	1
6	PBOZZ	53945	6650	.HOSE ASSEMBLY, NONME .....	1
7	PBOZZ	53945	6649	.HOSE ASSEMBLY, NONME .....	2
8	PBOFZ	53945	94645	.MOTOR-PUMP, HYDRAULI SEE FIG 17 .....	1
				FOR BREAKDOWN .....	
9	PBOZZ	53945	2025	.GASKET .....	1
10	PBOZZ	53945	2027	.GASKET .....	1
11	XBOZZ	81646	115240	.CLAMP, HOSE .....	4
12	XBOZZ	20282	0500-210	TUBING .....	1
13	PAOZZ	52905	151214	.STRAINER ELEMENT, SE .....	1
14	PBOFZ	53945	6718	.VALVE, BALL .....	1
15	XBOZZ	81646	6828	.CLAMP, HOSE .....	2
16	XBOZZ	16327	5X716	.BALL, VALVE .....	1
17	PAOZZ	53945	152240	.VALVE, GATE .....	1
18	PBOZZ	53945	3342	.CLAMP KIT, HOSE .....	1
19	PAOZZ	52905	104000	.SWITCH, LIQUID LEVEL .....	1
20	XBOZZ	81646	6824	.CLAMP, HOSE .....	2
21	XBOZZ	53945	126285	.TUBING .....	1

END OF FIGURE





SECTION II TM 5-3740-218-13&P

(1) ITEM NO	(2) SMR CODE	(3) CAGEC	(4) PART NUMBER	(5) DESCRIPTION AND USABLE ON CODES(UOC)	(6) QTY
-------------------	--------------------	--------------	-----------------------	---	------------

GROUP 02 LIQUID DISPERSAL SYSTEM

FIG. 17 HYDRAULIC MOTOR AND CHEMICAL PUMP ASSEMBLY

1	PAOFF	12008	MC15S6AH23B	MOTOR, HYDRAULIC .....	1
2	PAOFZ	53945	2815	PUMP, CENTRIFUGAL .....	1
3	PAFZZ	53945	112720	WASHER, SEAL .....	16
4	PAFZZ	53945	2029	GASKET PART OF KIT P/N x928150 .....	2
5	PAFZZ	52905	C-2055	IMPELLER, FAN, CENTRI .....	1
6	PAFZZ	52905	A-2155	SEAL ASSEMBLY, SHAFT PART OF KIT P/N 928150.....	1
7	PAFZZ	79136	55505(ND)	BEARING, SLEEVE PART OF KIT P/N 928150.....	1
			928150	PARTS KIT, BEARING R .....	1
				BEARING, SLEEVE ( 1) 17-7	
				GASKET ( 2) 17-4	
				SEAL ASSEMBLY, SHAFT( 1) 17-6	
	PAFZZ	52905	127190-1402-635	.PARTS KIT, RECIPROCA .....	1

END OF FIGURE

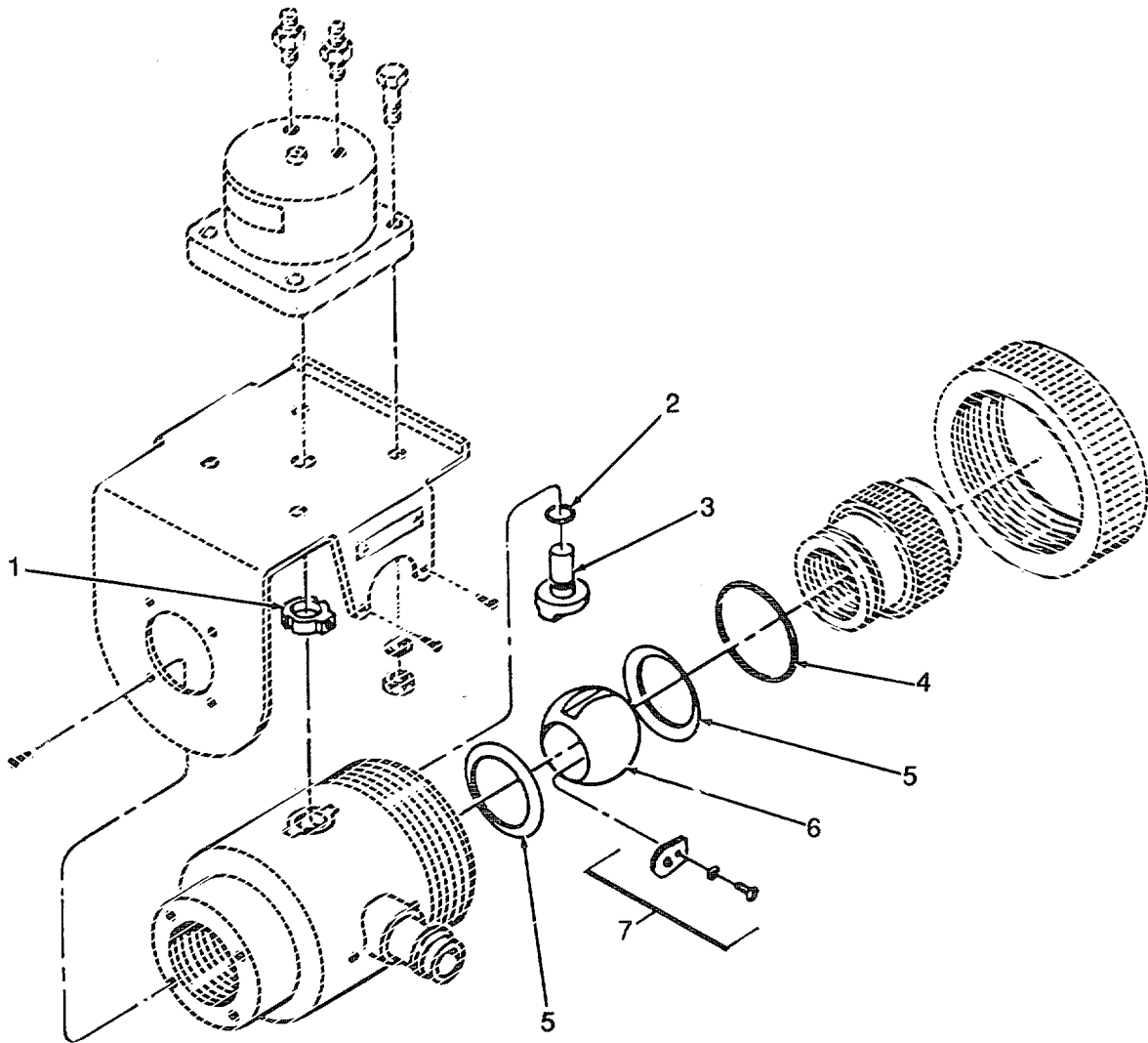

Figure F-18. Spray System Control

Change 1

F-46

SECTION II

TM 5-3740-218-13&P

(1) ITEM NO	(2) SMR CODE	(3) CAGEC	(4) PART NUMBER	(5) DESCRIPTION AND USABLE ON CODES(UOC)	(6) QTY
-------------------	--------------------	--------------	-----------------------	---	------------

GROUP 02 LIQUID DISPERSAL SYSTEM

FIG. 18 SPRAY SYSTEM CONTROL

1	XBFZZ	53945	103040	..SHAFT COLLAR, ALUM .....	1
2	XBFZZ	02697	113	..O-RING PART OF KIT P/N 4439 .....	1
3	XBFZZ	53945	B-5692	..TURN STEM .....	1
4	XBFZZ	53945	152291	..O-RING PART OF KIT P/N 4439 .....	1
5	XBFZZ	53945	152295	..SEAT, TEFLON PART OF KIT P/N 4439.....	2
6	XBFZZ	53945	4421	..BALL, MODIFICATION PART OF KIT P/N 4439 .....	1
7	XBFZZ	53945	4436	..DIAPHRAGM ASSY PART OF KIT P/N 4439 .....	1
	PBFZZ	53945	4439	..PARTS KIT, VALVE .....	1
				BALL, MODIFICATION ( 1) 18-6	
				DIAPHRAGM ASSY ( 1) 18-7	
				O-RING ( 1) 18-2	
				O-RING ( 1) 18-4	
				SEAT, TEFLON ( 2) 18-5	

END OF FIGURE

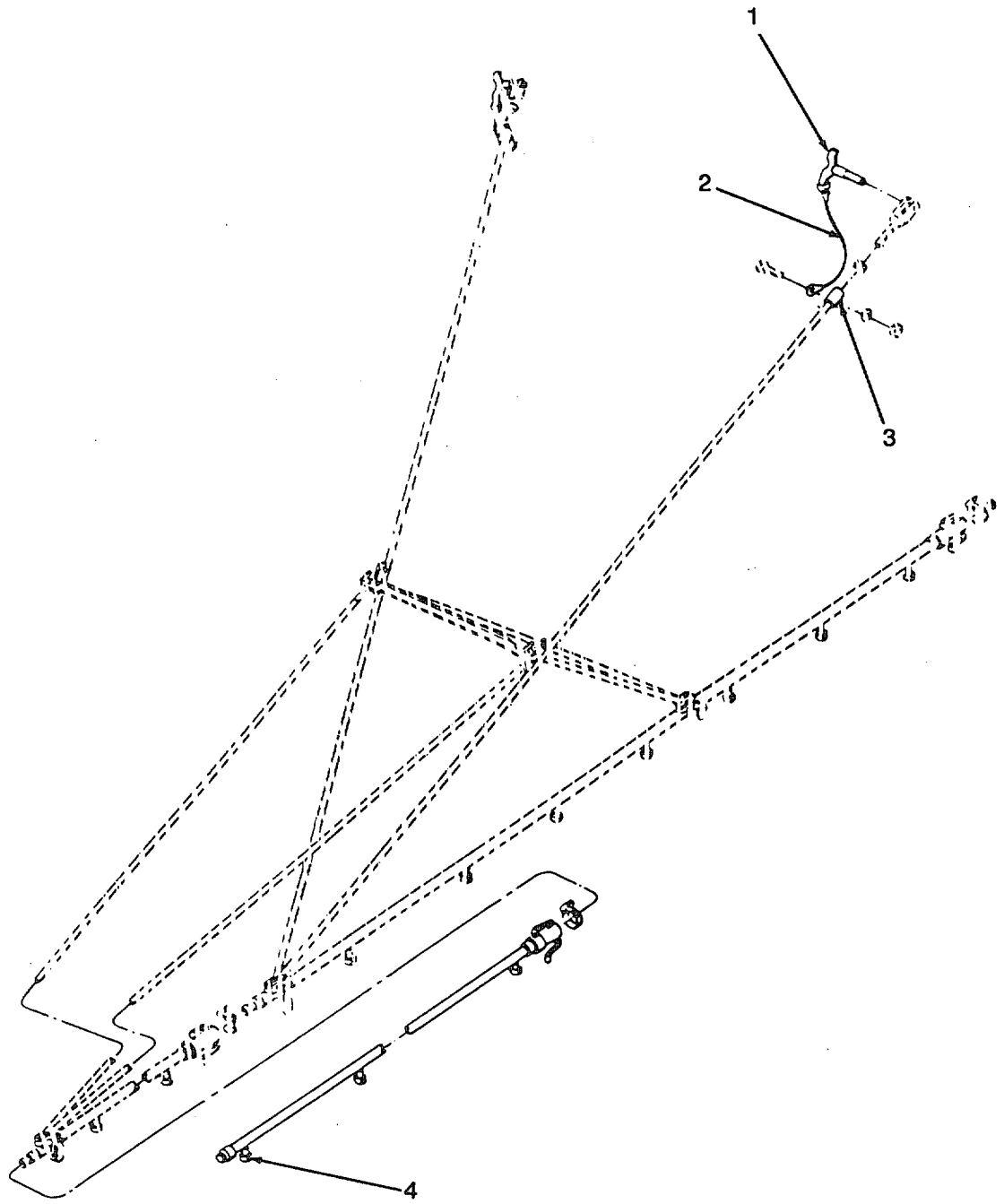

Figure F-19. Low Volume Boom Assembly

Change 1

F-48

## SECTION II

TM10-4320-303-23P

(1) ITEM NO	(2) SMR CODE	(3) CAGEC	(4) PART NUMBER	(5) DESCRIPTION AND USABLE ON CODES(UOC)	(6) QTY
				GROUP 02 LIQUID DISPERSAL SYSTEM	
				FIG. 19 LOW VOLUME BOOM ASSEMBLY	
1	XBOZZ	96906	MS17985-507	.PIN, QUICK RELEASE .....	14
2	XBOZZ	84256	L-8-T6-V	.WIRE ROPE ASSY .....	14
3	XBOZZ	96906	MS21919WDG20	.CLAMP, LOOP .....	6
4	PAOOZ	82247	QJT8360-NYB	.NOZZLE, SPRAY, FLUID- .....	34

END OF FIGURE

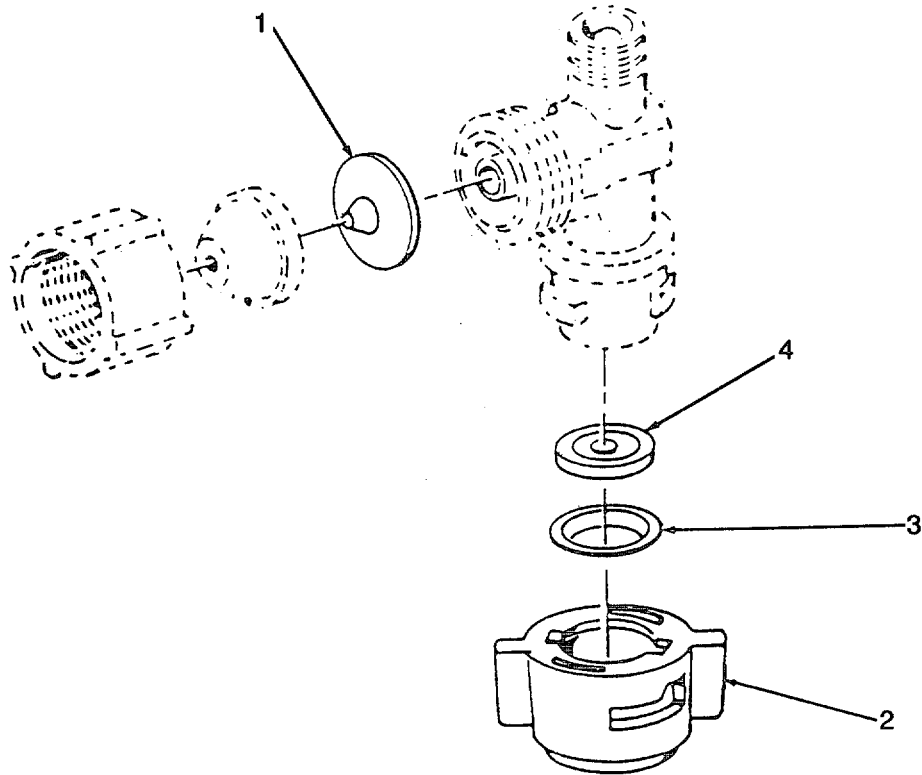

Figure F-20. Low Volume Nozzle Assembly

Change 1 F-50

## SECTION II

TM5-3740-218-13&amp;P

(1) ITEM NO	(2) SMR CODE	(3) CAGEC	(4) PART NUMBER	(5) DESCRIPTION AND USABLE ON CODES(UOC)	(6) QTY
				GROUP 02	
				LIQUID DISPERSAL SYSTEM	
				FIG. 20	
				LOW VOLUME NOZZLE ASSEMBLY	
1	XBOZZ	82247	4620V1	..DIAPHRAGM, RELIEF .....	1
2	PBOZZ	52905	151883	..CAP, PROTECTIVE, DUST .....	1
3	XBOZZ	82247	D4	..DISC, SPRAYING .....	1
4	PBOZZ	52905	151927	..SEAL, NONMETALLIC, AN .....	1

END OF FIGURE



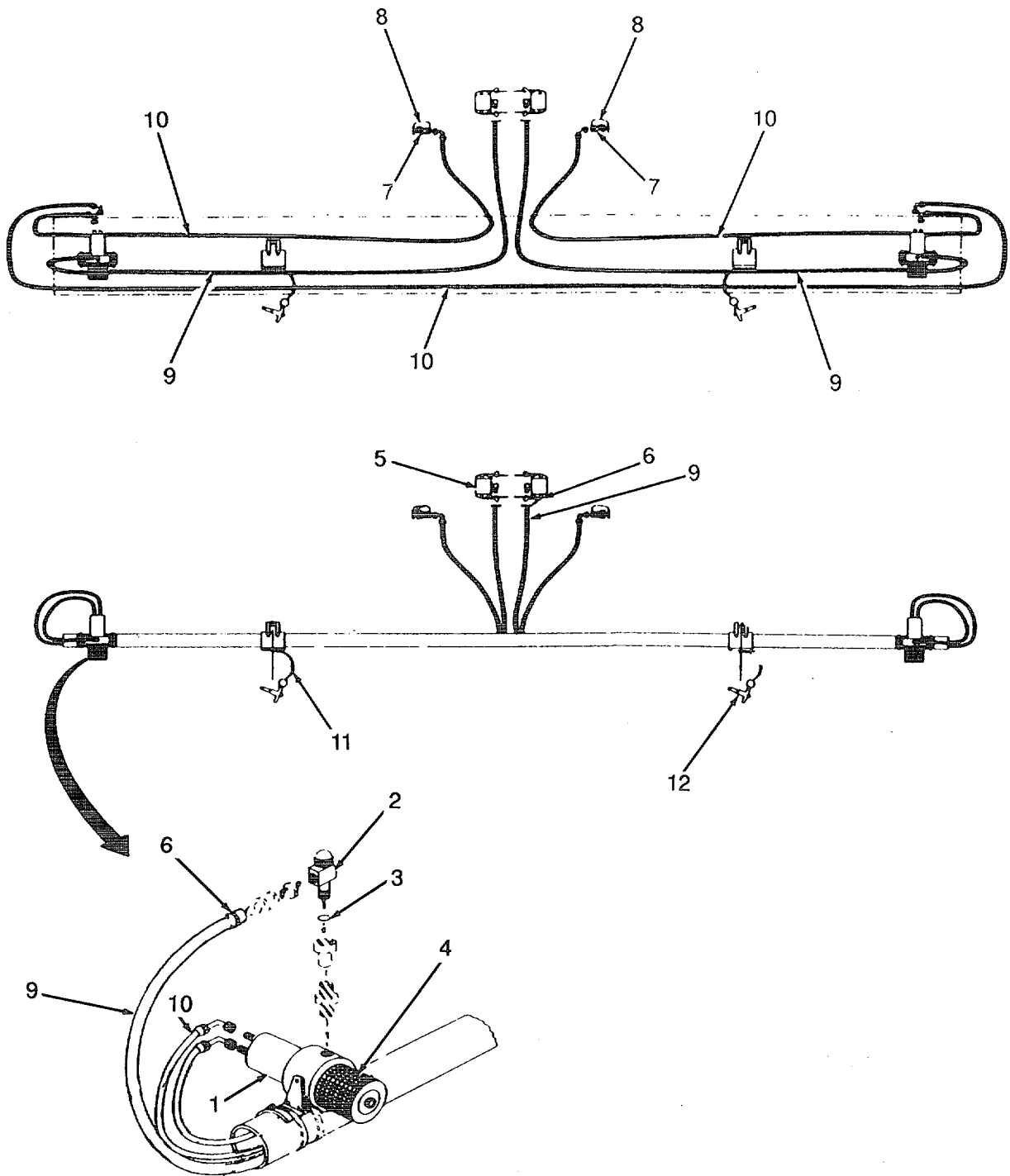

Figure F-21. Ultra-Low Volume Boom Assembly

Change 1 F-52

## SECTION II

TM10-4320-303-23P

(1) ITEM NO	(2) SMR CODE	(3) CAGEC	(4) PART NUMBER	(5) DESCRIPTION AND USABLE ON CODES(UOC)	(6) QTY
				GROUP 02 LIQUID DISPERSAL SYSTEM	
				FIG. 21 ULTRA-LOW VOLUME BOOM ASSEMBLY	
	XCOOO	53945	96822	HYDRAULIC ULV SPRAY .....	1
1	PAOOO	52905	157020	.ATOMIZER .....	2
2	PBOZZ	52905	151400	.DIAPHRAGM, VALVE, SPE .....	2
3	PBOZZ	82247	D4	.DISC, SPRAYING . .....	2
4	PBOZZ	52905	157035	.FILTER ELEMENT, FLUI .....	2
5	PBOZZ	53945	6766	.CAP, VALVE .....	2
6	PBOZZ	96906	MS21919WDG8	.CLAMP, LOOP .....	4
7	XBOZZ	78357	VHC4-4EM	.COUPLING HALF, QUICK .....	2
8	PBOZZ	52905	118174	.PLUG, PROTECTIVE, DUS .....	2
9	PBOZZ	52905	126088	.HOSE ASSEMBLY, NONME .....	2
10	PBOZZ	61424	540N4	.HOSE, NONMETALLIC .....	V
11	XBOZZ	84256	L-8-T6-V	.WIRE ROPE ASSY .....	1
12	PBOZZ	53945	114453	.PIN, QUICK RELEASE .....	2

END OF FIGURE

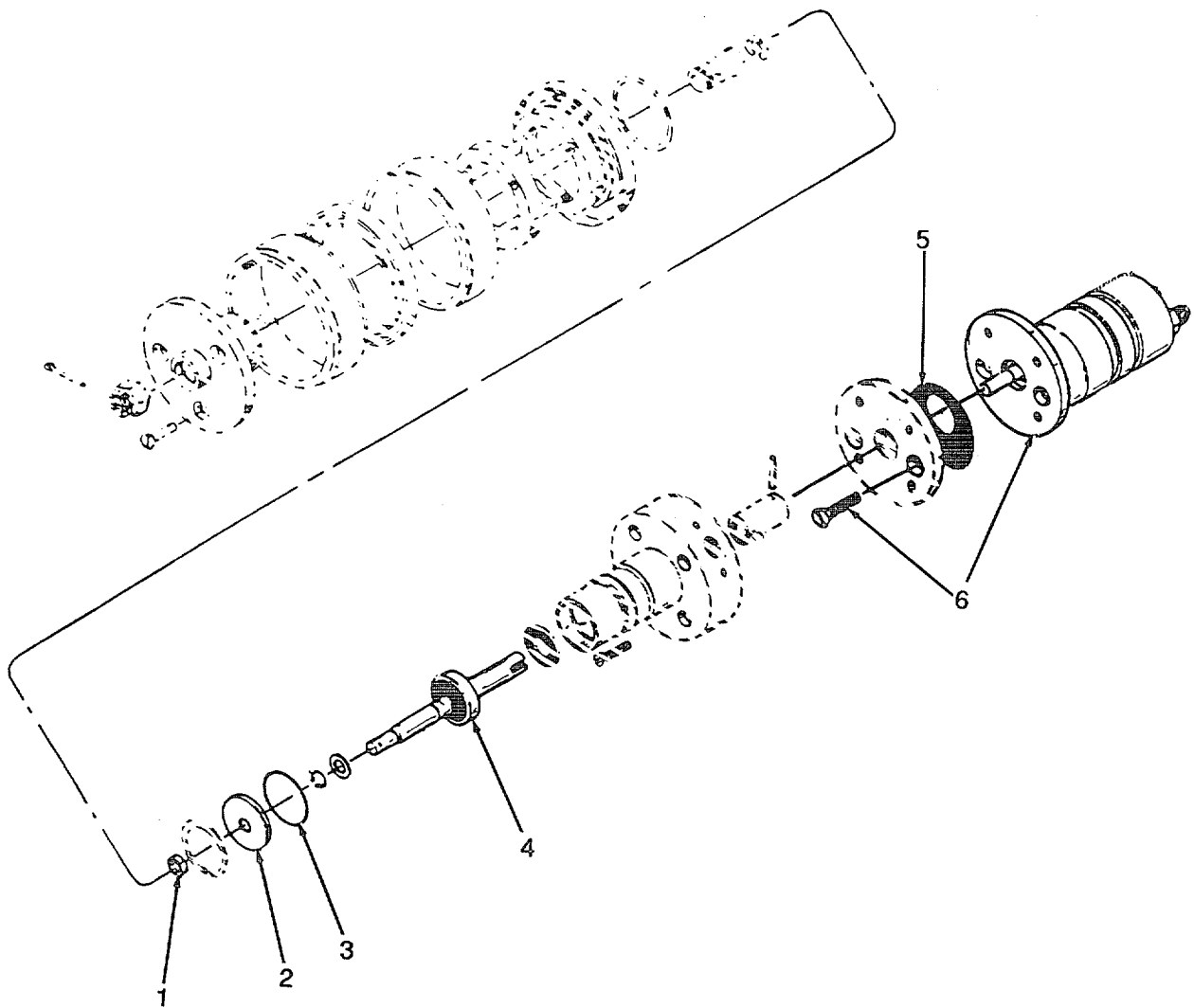

Figure F-22. Rotary Atomizer

Change 1 F-54

SECTION II					
(1)	(2)	(3)	(4)	(5)	(6)
ITEM	SMR		PART		
NO	CODE	CAGEC	NUMBER	DESCRIPTION AND USABLE ON CODES(UOC)	QTY
				GROUP 02 LIQUID DISPERSAL SYSTEM	
				FIG. 22 ROTARY ATOMIZER	
1	XBOZZ	65387	360048	..SEAL, FRONT.....	2
2	XBOZZ	65387	360050	..SEAL, PLATE.....	1
3	XBOZZ	65387	360015	..SEAL, BEARING.....	1
4	XBOZZ	65387	360020	..BEARING, SEALED.....	1
5	XBOZZ	65387	360011	..GASKET, MOTOR.....	1
6	XBOZZ	65387	360021	..MOTOR, HYDRAULIC.....	1

END OF FIGURE

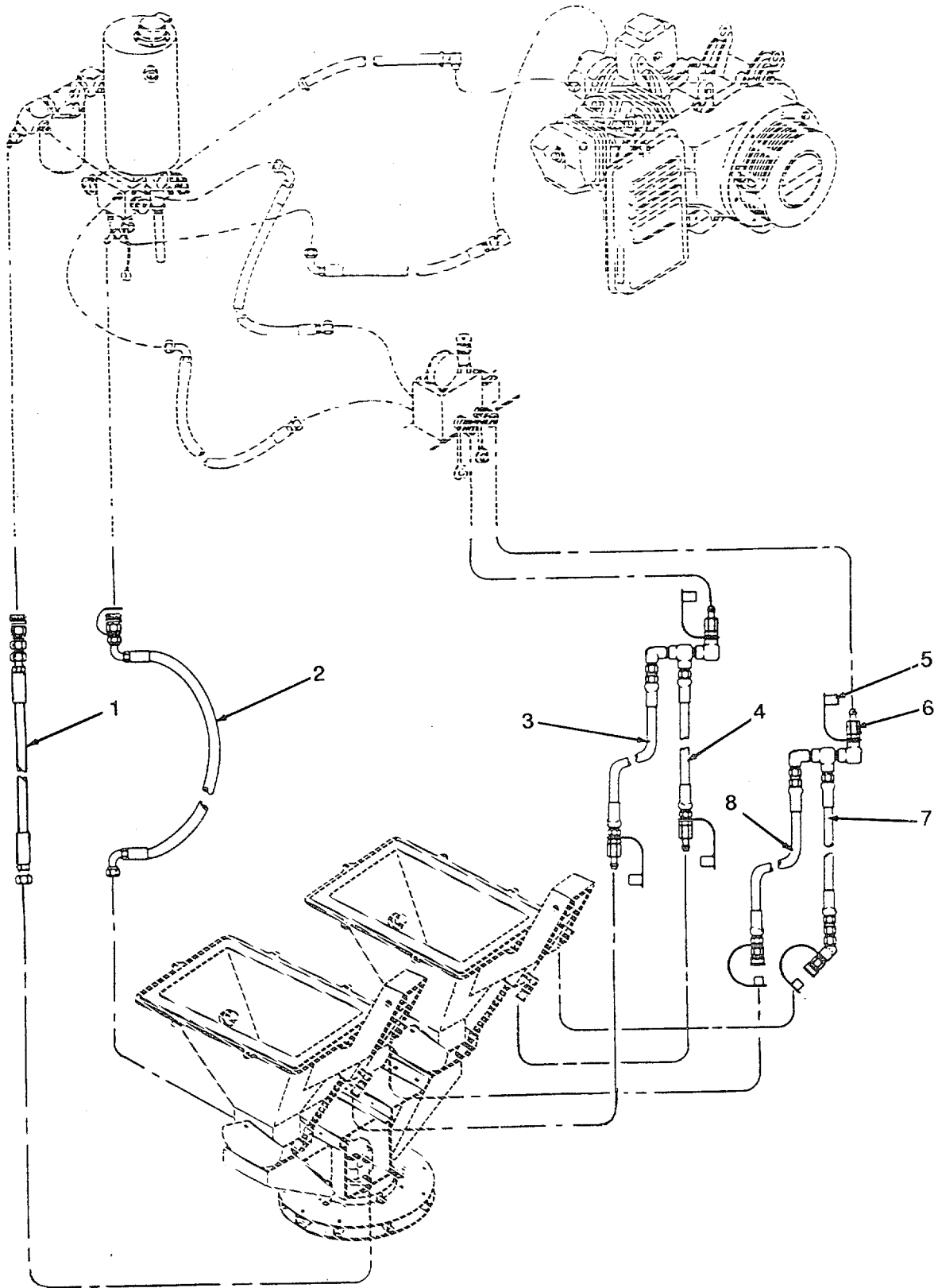

Figure F-23. Dry System Hydraulic Installation

SECTION II					
(1)	(2)	(3)	(4)	(5)	(6)
ITEM	SMR		PART		
NO	CODE	CAGEC	NUMBER	DESCRIPTION AND USABLE ON CODES(UOC)	QTY
				GROUP 03	SOLID DISPERSAL SYSTEM
				FIG. 23	DRY SYSTEM HYDRAULIC INSTALLATION
	XCOOO	53945	96832	, HYD, SCHEMATIC, DRY .....	1
1	PBOZZ	53945	99952	..HOSE ASSEMBLY, NONME .....	1
2	PBOZZ	53945	9612	..HOSE, NONMETALLIC .....	1
3	PBOZZ	53945	99108	..HOSE ASSEMBLY, NONME .....	1
4	PBOZZ	53945	99161	..HOSE ASSEMBLY, NONME .....	1
5	XBOZZ	78357	PDC-4	..CAP, DUST .....	2
6	PBOZZ	52905	118275	..NIPPLE, HOSE.....	2
7	PBOZZ	53945	99106	..HOSE ASSEMBLY, NONME .....	1
8	PBOZZ	53945	99107	..HOSE ASSEMBLY, NONME .....	1

END OF FIGURE

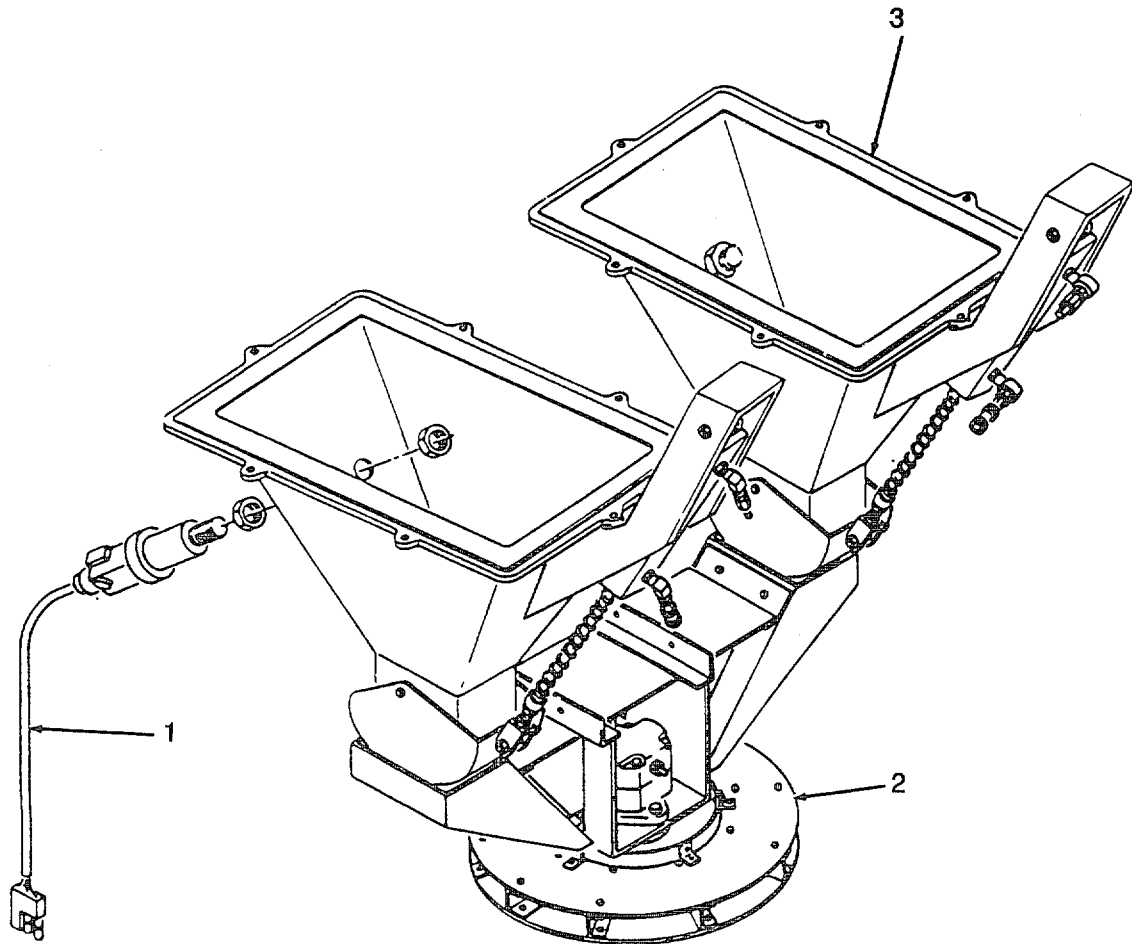

Figure F-24. Dry System Slinger/Hopper Assembly

Change 1 F-58 Change

SECTION II

TM5-3740-218-13&P

(1) ITEM NO	(2) SMR CODE	(3) CAGEC	(4) PART NUMBER	(5) DESCRIPTION AND USABLE ON CODES(UOC)	(6) QTY
				GROUP 03 SOLID DISPERSAL SYSTEM	
				FIG. 24 DRY SYSTEM SLINGER/HOPPER ASSEMBLY	
1	PAFZZ	53945	6107	.WIRING HARNESS .....	1
2	PAOFZ	53945	96680	.PUMP, FORMULATION, IN .....	1
3	PAOOO	53945	96735	.HOPPER ASSEMBLY .....	2

END OF FIGURE



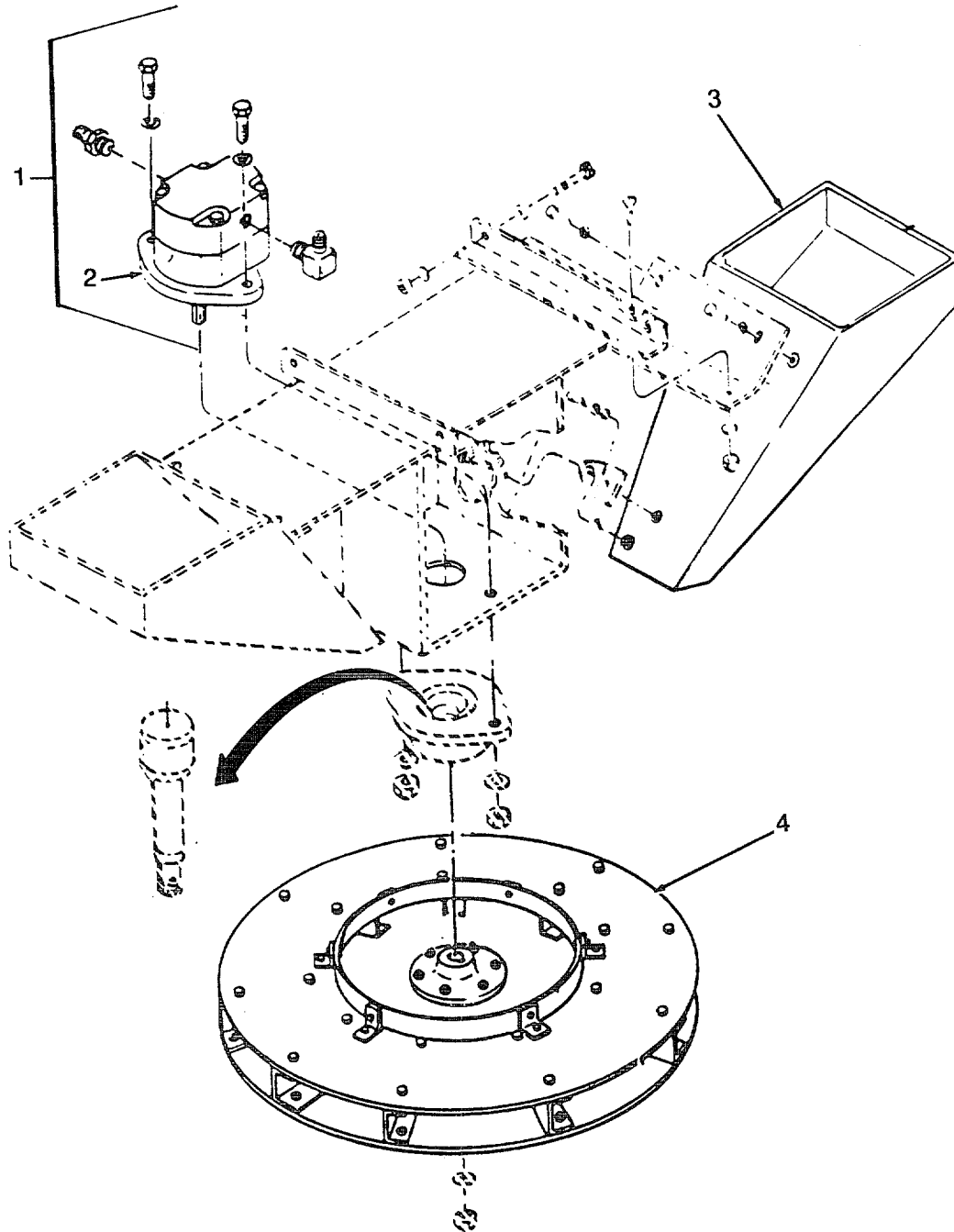

Figure F-25. Pump and Slinger Assembly

Change 1 F-60

SECTION II					
(1)	(2)	(3)	(4)	(5)	(6)
ITEM NO	SMR CODE	CAGEC	PART NUMBER	DESCRIPTION AND USABLE ON CODES(UOC)	QTY
				GROUP 03	SOLID DISPERSAL SYSTEM
				FIG. 25	PUMP AND SLINGER ASSEMBLY
1	PAOFZ	53945	6672	..MOTOR, HYDRAULIC .....	1
2	PAOFF	12008	MC15S6AH23B	...MOTOR, HYDRAULIC .....	1
3	PAOZZ	53945	96682	..CHUTE, DISPERSAL .....	1
4	PAOZZ	53945	96843	..SLINGER ASSEMBLY .....	1
	PAFZZ	12008	1402635-001	..PARTS REPAIR KIT .....	1

END OF FIGURE

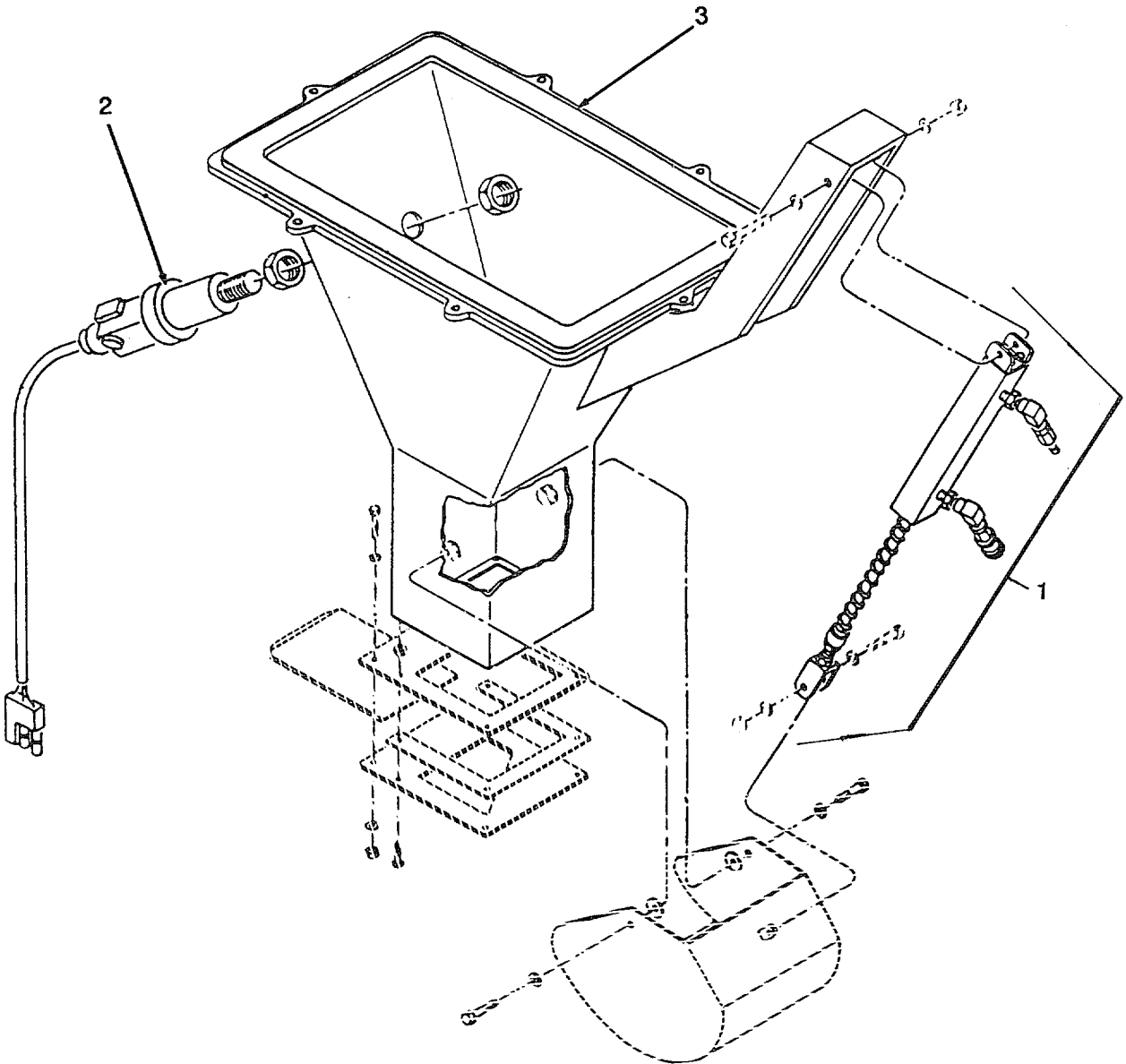

Figure F-26. Dry System Hopper Assembly

Change 1 F-62

SECTION II					
(1)	(2)	(3)	(4)	(5)	(6)
ITEM NO	SMR CODE	CAGEC	PART NUMBER	DESCRIPTION AND USABLE ON CODES(UOC)	QTY
				GROUP 03 SOLID DISPERSAL SYSTEM	
				FIG. 26 DRY SYSTEM HOPPER ASSEMBLY	
1	PBOZZ	53945	6705	..CYLINDER ASSEMBLY, A .....	2
2	XBOZZ	61526	BC10-P30SR-VN4X	..SWITCH, CAP LIGHT .....	2
3	PBOZZ	53945	539	..GASKET .....	2

END OF FIGURE

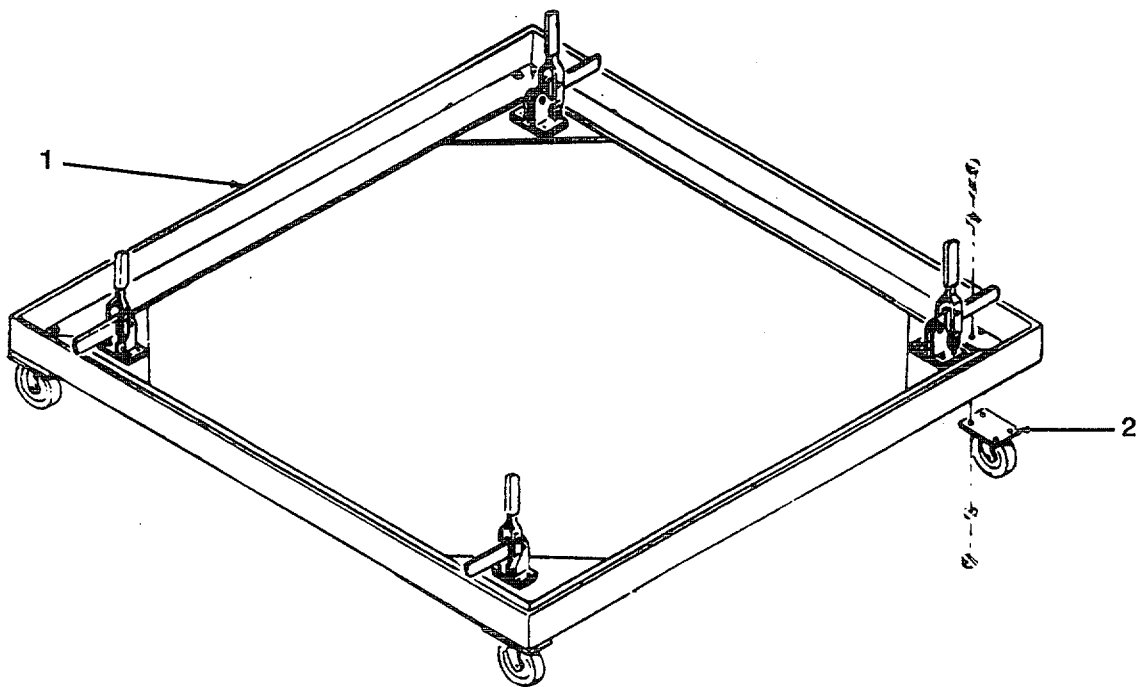

Figure F-27. Dolly Assembly

Change 1 F-64

SECTION II

(1) ITEM NO	(2) SMR CODE	(3) CAGEC	(4) PART NUMBER	(5) DESCRIPTION AND USABLE ON CODES(UOC)	(6) QTY
GROUP 04 DOLLY ASSEMBLY					
FIG.27 DOLLY ASSEMBLY					
1	XDOOO	53945	6890	DOLLY ASSY .....	1
2	PBOZZ	52905	153900	CASTER, SWIVEL .....	4

END OF FIGURE

**Section III. Special Tools**

**Not Applicable**

## CROSS-REFERENCE INDEXES

NATIONAL STOCK NUMBER INDEX					
STOCK NUMBER	FIG.	ITEM	STOCK NUMBER	FIG.	ITEM
5920-00-012-0151	4	8	4720-01-359-4917	6	4
4330-00-073-0371	14	1	4820-01-359-4989	14	11
3110-00-198-2321	17	7	4730-01-359-5719	16	18
4730-00-204-3425	12	4	4820-01-359-5736	16	17
5340-00-291-5347	21	6	4730-01-359-5750	19	4
4720-00-405-4123	21	10	4320-01-359-5766	17	5
3740-00-481-3526	21	3	4320-01-359-8438	17	1
5975-00-727-5153	16	2		25	2
5950-01-358-2643	14	14	5330-01-359-8923	16	10
5950-01-358-2644	13	3	5340-01-360-1407	2	2
5330-01-358-4567	6	3	4810-01-360-2411	18	
4010-01-358-5453	2	5	4720-01-360-4358	16	4
5930-01-358-5501	16	19	3120-01-360-7578	17	
5330-01-358-5559	16	1	4720-01-360-7921	23	2
	26	3	4720-01-360-7922	23	8
5930-01-358-5607	4	3	4720-01-360-7923	23	3
5340-01-358-7271	20	2	4720-01-360-9207	23	7
5340-01-358-7272	21	8	4720-01-360-9208	23	4
5340-01-358-7592	27	2	4720-01-361-0506	23	1
6150-01-358-7816	16	3	4720-01-361-2275	16	7
6150-01-358-7817	24	1	4720-01-361-2276	16	6
4730-01-358-8187	16	13	4720-01-361-2277	16	5
5330-01-358-8337	20	4			
5330-01-358-8435	17	3			
5330-01-358-8438	16	9			
5330-01-358-8439	17	4			
4820-01-358-8476	14	12			
4820-01-358-8481	14	9			
4810-01-358-8486	13	4			
4810-01-358-8490	16	14			
4730-01-358-8527	23	6			
4320-01-358-8563	17	2			
4320-01-358-8566	11	1			
4820-01-358-8604	13				
4810-01-358-8611	21	5			
2910-01-358-8626	5	1			
2940-01-358-8652	6	2			
5895-01-358-8670	2	3			
2990-01-358-8707	2	13			
3740-01-358-8876	25	3			
3740-01-358-8877	25	4			
4320-01-359-0654	16	8			
3040-01-359-0684	26	1			
4320-01-359-1076	21	4			
2920-01-359-2032	10	1			
4320-01-359-2082	25	1			
4810-01-359-2264	21	2			
4720-01-359-2413	21	9			
4320-01-359-2470	17				
4320-01-359-2834	24	2			



## CROSS-REFERENCE INDEXES

CAGEC	PART NUMBER	PART NUMBER INDEX		FIG.	ITEM
			STOCK NUMBER		
52905	A-2155			17	6
12008	AB1010-3(F-EZY)			14	2
55524	AB1103			12	1
60886	AP2M211-A			15	5
60886	AP2M211-G			15	6
53945	B-5692			18	3
61526	BC100-P30SR-VN4X			26	2
6V397	BHB121-J			13	13
6V397	BHCP			13	12
12008	B24303-RBAJ	4320-01-358-8566		11	1
52905	C-2055	4320-01-359-5766		17	5
53945	DC607-4			3	4
82247	D4			20	3
		3740-00-481-3526		21	3
81349	F02A32V15A	5920-00-012-0151		4	8
72794	GP5			2	18
02249	K22001	4330-00-073-0371		14	1
84256	L-8-T6-V			19	2
				21	11
12008	L5P151-5			14	3
12008	MC15S6AH23B	4320-01-359-8438		17	1
				25	2
96906	MS17985-507			19	1
96906	MS21919WDG20			19	3
96906	MS21919WDG6			13	9
96906	MS21919WDG8	5340-00-291-5347		21	6
96906	MS21919WD68			12	2
96906	MS25306-222			15	4
96906	MS25306-262			15	3
96906	MS25307-232			15	2
96906	MS3101A20-33P			2	8
96906	MS3106A20-33S			2	7
96906	MS3367-4-9	5975-00-727-5153		16	2
96906	MS3452W20-33P			15	7
78357	PDC-4			23	5
82247	QJT8360-NYB	4730-01-359-5750		19	4
78357	VHC4-4EM			21	7
81640	W301			15	1
20282	0500-210			16	12
53945	102900			2	1
53945	103040			18	1
52905	104000	5930-01-358-5501		16	19
53945	107540			2	4
53945	107745			13	14
53945	112720	5330-01-358-8435		17	3
02697	113			18	2
53945	114453			21	12
81646	115240			16	11
52905	118174	5340-01-358-7272		21	8
52905	118275	4730-01-358-8527		23	6
53945	123522			5	4

## CROSS-REFERENCE INDEXES

CAGEC	PART NUMBER	PART NUMBER INDEX		FIG.	ITEM
			STOCK NUMBER		
52905	123525		2940-01-358-8652	6	2
52905	123532		5330-01-358-4567	6	3
52905	123533		4720-01-359-4917	6	4
53945	123536			5	2
53945	123538			5	3
53945	123539			5	5
53945	123541			5	6
53945	123555			9	2
53945	123556			9	1
53945	123557			9	3
53945	123558			9	5
53945	123559			9	6
53945	123562			10	2
53945	125100			13	2
53945	126005			12	3
52905	126088		4720-01-359-2413	21	9
53945	126285			16	21
52905	127190-1402-635		4320-01-359-2470	17	
53945	128135			14	13
12008	1402635-001			25	
52905	151214		4730-01-358-8187	16	13
52905	151400		4810-01-359-2264	21	2
52905	151883		5340-01-358-7271	20	2
52905	151927		5330-01-358-8337	20	4
53945	152210			14	5
53945	152240		4820-01-359-5736	16	17
53945	152291			18	4
53945	152295			18	5
52905	152748		5950-01-358-2644	13	3
53945	152753		4810-01-358-8486	13	4
53945	152754			13	6
53945	152755			13	5
53945	152756		4820-01-358-8604	13	
52905	152757			13	
53945	152762		4820-01-358-8481	14	9
53945	152763		4820-01-359-4989	14	11
53945	152764			14	10
53945	152765		4820-01-358-8476	14	12
53945	152766			14	
53945	152767			14	
53945	152768			14	
53945	152769			14	
53945	152771		5950-01-358-2643	14	14
52905	153900		5340-01-358-7592	27	2
53945	156110			2	12
53945	15625-ZE1-000			9	4
52905	157020			21	1
52905	157035		4320-01-359-1076	21	4
30327	192J		4730-00-204-3425	12	4
02697	2-011-V747-75			13	7
02697	2-121 V747-75			14	8

## CROSS-REFERENCE INDEXES

CAGEC	PART NUMBER	PART NUMBER INDEX		FIG.	ITEM
			STOCK NUMBER		
53945	2025		5330-01-358-8438	16	9
53945	2027		5330-01-359-8923	16	10
53945	2029		5330-01-358-8439	17	4
12008	24300-902			11	
53945	2815		4320-01-358-8563	17	2
S0208	31210-ZE3-013		2920-01-359-2032	10	1
53945	3342		4730-01-359-5719	16	18
71400	342			4	7
65387	360011			22	5
65387	360015			22	3
65387	360020			22	4
65387	360021			22	6
65387	360048			22	1
65387	360050			22	2
53945	4421			18	6
53945	4436			18	7
53945	4439		4810-01-360-2411	18	
70485	452			4	4
82247	4620VI			20	1
53945	4622			14	7
16327	5X716			16	16
81860	505-3-NS			13	8
53945	539		5330-01-358-5559	16	1
				26	3
61424	540N4		4720-00-405-4123	21	10
79136	55505(ND)		3110-00-198-2321	17	7
53945	5758			14	6
53945	6089			2	9
53945	6107		6150-01-358-7817	24	1
53945	6108		6150-01-358-7816	16	3
53945	6109			13	10
53945	6111			13	11
53945	6114			4	1
53945	6117			4	2
53945	6118		5930-01-358-5607	4	3
53945	6122			2	10
53945	6124			3	3
52970	64			8	1
53945	6601			7	2
53945	6602		2990-01-358-8707	2	13
53945	6628			2	6
53945	6641			2	17
53945	6649		4720-01-361-2275	16	7
53945	6650		4720-01-361-2276	16	6
53945	6670		5895-01-358-8670	2	3
53945	6672		4320-01-359-2082	25	1
53945	6679		5340-01-360-1407	2	2
53945	6705		3040-01-359-0684	26	1
53945	6718		4810-01-358-8490	16	14
53945	6730		4010-01-358-5453	2	5
53945	6766		4810-01-358-8611	21	5

## CROSS-REFERENCE INDEXES

CAGEC	PART NUMBER	PART NUMBER INDEX		FIG.	ITEM
			STOCK NUMBER		
53945	6802			13	
81646	6824			16	20
81646	6828			16	15
52905	6837			13	1
53945	6890			27	1
53945	7136		2910-01-358-8626	5	1
53945	7149			6	1
2V131	82F-157-NBL			4	5
2V131	82M-157-NB			4	6
53945	9056		4720-01-360-4358	16	4
53945	928150		3120-01-360-7578	17	
53945	94645		4320-01-359-0654	16	8
53945	94647			3	2
53945	9612		4720-01-360-7921	23	2
53945	96603			7	1
53945	96680		4320-01-359-2834	24	2
53945	96682		3740-01-358-8876	25	3
53945	96710			1	4
53945	96714			1	2
53945	96724			3	1
53945	96735			24	3
53945	96771			2	14
53945	96780			14	4
53945	96781			2	11
53945	96801			1	1
53945	96806			2	16
53945	96808			2	15
53945	96812			16	
53945	96821			1	3
53945	96822			21	
53945	96830			1	5
53945	96832			23	
53945	96843		3740-01-358-8877	25	4
53945	9811		4720-01-361-2277	16	5
53945	99106		4720-01-360-9207	23	7
53945	99107		4720-01-360-7922	23	8
53945	99108		4720-01-360-7923	23	3
53945	99161		4720-01-360-9208	23	4
53945	99952		4720-01-361-0506	23	1

## CROSS-REFERENCE INDEXES

FIG.	ITEM	FIGURE AND ITEM NUMBER INDEX STOCK NUMBER	CAGEC	PART NUMBER
1	1		53945	96801
1	2		53945	96714
1	3		53945	96821
1	4		53945	96710
1	5		53945	96830
2	1		53945	102900
2	2	5340-01-360-1407	53945	6679
2	3	5895-01-358-8670	53945	6670
2	4		53945	107540
2	5	4010-01-358-5453	53945	6730
2	6		53945	6628
2	7		96906	MS3106A20-33S
2	8		96906	MS3101A20-33P
2	9		53945	6089
2	10		53945	6122
2	11		53945	96781
2	12		53945	156110
2	13	2990-01-358-8707	53945	6602
2	14		53945	96771
2	15		53945	96808
2	16		53945	96806
2	17		53945	6641
2	18		72794	GP5
3	1		53945	96724
3	2		53945	94647
3	3		53945	6124
3	4		53945	DC607-4
4	1		53945	6114
4	2		53945	6117
4	3	5930-01-358-5607	53945	6118
4	4		70485	452
4	5		2V131	82F-157-NBL
4	6		2V131	82M-157-NB
4	7		71400	342
4	8	5920-00-012-0151	81349	F02A32V15A
5	1	2910-01-358-8626	53945	7136
5	2		53945	123536
5	3		53945	123538
5	4		53945	123522
5	5		53945	123539
5	6		53945	123541
6	1		53945	7149
6	2	2940-01-358-8652	52905	123525
6	3	5330-01-358-4567	52905	123532
6	4	4720-01-359-4917	52905	123533
7	1		53945	96603
7	2		53945	6601
8	1		52970	64
9	1		53945	123556
9	2		53945	123555
9	3		53945	123557

## CROSS-REFERENCE INDEXES

FIG.	ITEM	FIGURE AND ITEM NUMBER INDEX STOCK NUMBER	CAGEC	PART NUMBER
9	4		53945	15625-ZE1-000
9	5		53945	123558
9	6		53945	123559
10	1	2920-01-359-2032	S0208	31210-ZE3-013
10	2		53945	123562
11			12008	24300-902
11	1	4320-01-358-8566	12008	B24303-RBAJ
12	1		55524	AB10103
12	2		96906	MS21919WD68
12	3		53945	126005
12	4	4730-00-204-3425	30327	192J
13			52905	152757
13			53945	6802
13		4820-01-358-8604	53945	152756
13	1		52905	6837
13	2		53945	125100
13	3	5950-01-358-2644	52905	152748
13	4	4810-01-358-8486	53945	152753
13	5		53945	152755
13	6		53945	152754
13	7		02697	2-011-V747-75
13	8		81860	505-3-NS
13	9		96906	MS21919WDG6
13	10		53945	6109
13	11		53945	6111
13	12		6V397	BHCP
13	13		6V397	BHB121-J
13	14		53945	107745
14			53945	152766
14			53945	152767
14			53945	152768
14			53945	152769
14	1	4330-00-073-0371	02249	K22001
14	2		12008	AB1010-3(F-EZY)
14	3		12008	L5P151-5
14	4		53945	96780
14	5		53945	152210
14	6		53945	5758
14	7		53945	4622
14	8		02697	2-121 V747-75
14	9	4820-01-358-8481	53945	152762
14	10		53945	152764
14	11	4820-01-359-4989	53945	152763
14	12	4820-01-358-8476	53945	152765
14	13		53945	128135
14	14	5950-01-358-2643	53945	152771
15	1		81640	W301
15	2		96906	MS25307-232
15	3		96906	MS25306-262
15	4		96906	MS25306-222
15	5		60886	AP2M211-A

## CROSS-REFERENCE INDEXES

FIG.	ITEM	FIGURE AND ITEM NUMBER INDEX STOCK NUMBER	CAGEC	PART NUMBER
15	6		60886	AP2M211-G
15	7		96906	MS3452W20-33P
16			53945	96812
16	1	5330-01-358-5559	53945	539
16	2	5975-00-727-5153	96906	MS3367-4-9
16	3	6150-01-358-7816	53945	6108
16	4	4720-01-360-4358	53945	9056
16	5	4720-01-361-2277	53945	9811
16	6	4720-01-361-2276	53945	6650
16	7	4720-01-361-2275	53945	6649
16	8	4320-01-359-0654	53945	94645
16	9	5330-01-358-8438	53945	2025
16	10	5330-01-359-8923	53945	2027
16	11		81646	115240
16	12		20282	0500-210
16	13	4730-01-358-8187	52905	151214
16	14	4810-01-358-8490	53945	6718
16	15		81646	6828
16	16		16327	5X716
16	17	4820-01-359-5736	53945	152240
16	18	4730-01-359-5719	53945	3342
16	19	5930-01-358-5501	52905	104000
16	20		81646	6824
16	21		53945	126285
17		3120-01-360-7578	53945	928150
17		4320-01-359-2470	52905	127190-1402-635
17	1	4320-01-359-8438	12008	MC1SS6AH23B
17	2	4320-01-358-8563	53945	2815
17	3	5330-01-358-8435	53945	112720
17	4	5330-01-358-8439	53945	2029
17	5	4320-01-359-5766	52905	C-2055
17	6		52905	A-2155
17	7	3110-00-198-2321	79136	55505(ND)
18		4810-01-360-2411	53945	4439
18	1		53945	103040
18	2		02697	113
18	3		53945	B-5692
18	4		53945	152291
18	5		53945	152295
18	6		53945	4421
18	7		53945	4436
19	1		96906	MS17985-507
19	2		84256	L-8-T6-V
19	3		96906	MS21919WDG20
19	4	4730-01-359-5750	82247	QJT8360-NYB
20	1'		82247	4620V1
20	2	5340-01-358-7271	52905	151883
20	3		82247	D4
20	4	5330-01-358-8337	52905	151927
21			53945	96822
21	1		52905	157020

## CROSS-REFERENCE INDEXES

FIG.	ITEM	FIGURE AND ITEM NUMBER INDEX		
		STOCK NUMBER	CAGEC	PART NUMBER
21	2	4810-01-359-2264	52905	151400
21	3	3740-00-481-3526	82247	D4
21	4	4320-01-359-1076	52905	157035
21	5	4810-01-358-8611	53945	6766
21	6	5340-00-291-5347	96906	MS21919WDG8
21	7		78357	VHC4-4EM
21	8	5340-01-358-7272	52905	118174
21	9	4720-01-359-2413	52905	126088
21	10	4720-00-405-4123	61424	540N4
21	11		84256	L-8-T6-V
21	12		53945	114453
22	1		65387	360048
22	2		65387	360050
22	3		65387	360015
22	4		65387	360020
22	5		65387	360011
22	6		65387	360021
23			53945	96832
23	1	4720-01-361-0506	53945	99952
23	2	4720-01-360-7921	53945	9612
23	3	4720-01-360-7923	53945	99108
23	4	4720-01-360-9208	53945	99161
23	5		78357	PDC-4
23	6	4730-01-358-8527	52905	118275
23	7	4720-01-360-9207	53945	99106
23	8	4720-01-360-7922	53945	99107
24	1	6150-01-358-7817	53945	6107
24	2	4320-01-359-2834	53945	96680
24	3		53945	96735
25			12008	1402635-001
25	1	4320-01-359-2082	53945	6672
25	2	4320-01-359-8438	12008	MC15S6AH23B
25	3	3740-01-358-8876	53945	96682
25	4	3740-01-358-8877	53945	96843
26	1	3040-01-359-0684	53945	6705
26	2		61526	BC10-P30SR-VN4X
26	3	5330-01-358-5559	53945	539
27	1		53945	6890
27	2	5340-01-358-7592	52905	153900

Change 1 F-75/(F-76 blank)



## APPENDIX G NOZZLE SELECTION AND SYSTEM CALIBRATION

### G-1. SELECTING NOZZLES FOR CALIBRATION

To properly select a nozzle, it must first be determined how many gpm each nozzle will have to put out. Once this is known, the chart for nozzle selection will aid in finding a nozzle with the right gpm. The formula for finding the gpm/nozzle is:

$$GPM/NOZ = \frac{GPA \times MPH \times SW}{\# NOZ \times 495}$$

Example: An operator wants to fly on 10 gallons per acre and fly 50 mph. The spray boom has 58 nozzles and the swath width is 90 feet. How many gpm will each nozzle have to put out?

$$GPM/NOZ = \frac{GPA \times MPH \times SW}{\# NOZ \times 495} = \frac{10 \times 50 \times 90}{58 \times 495} = 1.56 \text{ GPM/NOZ}$$

Answer: Each nozzle will have to put out 1.56 gpm/nozzle. By looking at the charts in the section for nozzle selection, a D-8 will meet this requirement. A D-8 equals 1.56 gpm/nozzle at 30 psi.

### G-2. NOZZLE SELECTION

The basic idea of nozzle selection is to find a nozzle that will perform to the application in the psi range available.

By listing all nozzle flows in gallons per minute at 30 psi, the job of nozzle selection can be simplified. With the following formulas, nozzles can be selected from the Spraying Systems and DeLavan charts regardless of the pressure at which they will be used.

$$GPM/NOZ \text{ at } 30 \text{ PSI} = \frac{GPA \times MPH \times \text{Nozzle Spacing}}{5940 \times \text{Conversion Number for New PSI}}$$

or

$$GPM/NOZ \text{ at } 30 \text{ PSI} = \frac{GPA \times MPH \times \text{Nozzle Spacing}}{495 \times \text{Conversion Number for New PSI}}$$

or

$$GPM/NOZ \text{ at } 30 \text{ PSI} = \frac{GPA \times MPH \times SW}{\# NOZ \times 495 \times \text{Conversion Number for New PSI}}$$

The PSI Conversion Numbers Chart is used to obtain the "conversion for new psi." The conversion number should correspond to the psi the nozzle will be performing at in its application.

The conversion number represents the formula: new PSI = 30 PSI

The variables of 1-1000 psi have been put in this formula and calculated out. The conversion factor is necessary to put into the formula since all nozzle flows in the charts are given for 30 psi. Any deviation from 30 psi requires a conversion number in the formula to correct the flow rate.

Example No. 1: An application requires 12 gallons per acre at 60 mph with nozzles spaced every 8 inches on the spray boom. The operator expects the psi to be around 35. What nozzles can be used that would be close to this requirement?

$$GPM/NOZ \text{ at } 30 \text{ PSI} = \frac{GPA \times MPH \times \text{Nozzle Spacing}}{5940 \times \text{Conversion Number for New PSI}}$$

$$GPM/NOZ \text{ at } 30 \text{ PSI} = \frac{12 \times 60 \times 8}{5940 \times 1.08} = 0.897$$

Answer: Nozzles that will deliver close to 0.897 gpm at 30 psi are:

D 10-45	0.94
D 6-56	0.95
D 14-25	0.88

Example No. 2: A grower has an orchard sprayer with 32 nozzles and will travel at 80 mph. The swath width is 50 feet. The grower plans to apply 16 gpa at 40 psi. What nozzle will perform to this application?

$$GPM/NOZ \text{ at } 30 \text{ PSI} = \frac{GPA \times MPH \times SW}{\# \text{ NOZ} \times 495 \times \text{Conversion Number for New PSI}}$$

$$GPM/NOZ \text{ at } 30 \text{ PSI} = \frac{16 \times 80 \times 50}{32 \times 495 \times 1.00} = 1.51$$

Answer: Nozzles that will deliver close to 1.51 gpm at 30 psi are:

D 14-45	1.54
D 8-46	1.59
D 8	1.50

### G-3. SYSTEM CALIBRATION

Three possible methods will be discussed that can be used to calibrate the system:

a. Flow Checks. The only method to calibrate a system before it leaves the ground is to time a given load of water. With the hydraulic driven pumps, the following formula can be applied:

$$TIME/Load = \frac{495 \times \# \text{ Gal/Load}}{\# \text{ of Gal/Acre} \times SW \times MPH}$$

Example: An application calls for 10 gpa at 50 mph with a swath width of 90 feet. The operator puts 50 gallons of water into the hopper. How long should it take to spray this out?

$$TIME/Load = \frac{495 \times \# \text{ Gal/Load}}{\# \text{ of Gal/Acre} \times SW \times MPH} = \frac{495 \times 50}{10 \times 90 \times 50} = 0.55 \text{ Minutes}$$

$$0.55 \text{ Minutes} \times 60 = 33 \text{ Seconds}$$

Answer: It should take 33 seconds to spray out 50 gallons.

b. **Swath Runs per Load Checks.** This method is most commonly used by airplane operators. Before taking off with a load, calculations should be made to find out how many swath runs can be made on a field without running out of chemical. The following formulas apply:

$$Swath \text{ Runs/Load} = \frac{\text{Acre Load in Hopper}}{\text{Acres per Swath Run}}$$

or

$$Swath \text{ Runs/Load} = \frac{\text{Acre Load in Hopper} \times 43560}{\text{Field Length} \times \text{Swath Width}}$$

Example: An operator wants to apply 10 gpa and the system carries 100 gallons, which means 10 acres in the hopper. The swath width is 90 feet and the field runs are 2,200 feet. How many passes can be made?

$$Swath \text{ Runs/Load} = \frac{\text{Acre Load in Hopper} \times 43560}{\text{Field Length} \times \text{Swath Width}} = \frac{10 \times 43560}{2200 \times 90} = 2.2 \text{ Swath Runs}$$

Answer: The operator can make two passes and should not attempt three without adjustments. See the Acre/Swath Chart.

c. **PSI Setting.** Although not commonly used as a means for accurate calibration, it should be mentioned as one method to aid in calibration. The formula for this method is:

$$PSI = \frac{(GPA \times MPH \times SW \text{ Ft})^2}{495 \times \# \text{ NOZ} \times GPM/NOZ \text{ at } 30 \text{ PSI}} \times 30$$

Example: An operator wants to apply 10 gpa at 100 mph with a swath width of 45 feet. The operator has 58 nozzles with D-7 orifices in them. What should the boom psi be? From the chart for nozzle selection, it is given that a D-7 puts out 1.25 gpm/nozzle at 30 psi. Substituting for the above formula appears as follows:

$$\frac{(10 \times 100 \times 45)^2}{495 \times 58 \times 1.25} \times 30 = PSI$$

$$(1.25)^2 \times 30 = 47.2 \text{ PSI}$$

Answer: The psi should be adjusted to 47.2.

**G-4. ACRE/SWATH CHART**

Two pieces of information are supplied by this chart:

- a. **Acres per Swath Run.** Acres are determined by swath width and length of swath run. Lengths of swath run are given in fractions of a mile, tenths of a mile, and increments of 100 feet up to 1 mile starting at 600 feet.
- b. **Seconds per Swath Run.** This information is a conversion of miles per hour to seconds per given distance. It has no relation to how wide the swath is. This information is reprinted exactly on the Acre/Swath Chart only as a convenience to the user.

**G-5. USES FOR ACRE/SWATH CHARTS**

- a. By using a stopwatch, you can determine the field length by flying a constant air speed. If the width is also measured, field acreage can easily be obtained:  $L \times W \times 43560 = \text{Acres}$ .
- b. By knowing the field length, you can obtain the acres per swath width.
- c. By dividing the acre load in the hopper by the acres per swath run, the number of passes can be obtained.

**NOTE**

For convenience, the column that gives air speed most used can be shaded in with a marking pen. This will save time searching for the correct column.

The rounding off of numbers was purposely left up to the user. This will give the user an idea of how much error is being put into the answers. Rounding off will make these charts more convenient and should not be discouraged.

**G-6. AIR APPLICATION FORMULAS**

- a. Acre/Swath Run  $= \frac{\text{Field Length} \times \text{Swath Width}}{43560}$
- b. Acre/Swath Run  $= \text{MPH} \times \text{SW} \times \text{Seconds Traveled} \times 0.0000337$   
 or  
 $= \frac{\text{MPH} \times \text{SW} \times \text{Seconds Traveled} \times 1.466}{43560}$
- c. Acre/Min  $= \text{MPH} \times \text{SW} \times 0.0020202$

- d. GPA  $= \frac{GPM \times 495}{MPH \times SW}$
- e. GPM  $= \frac{GPA \times MPH \times SW}{495}$
- f. GPM/NOZ  $= \frac{GPA \times MPH \times SW}{\# \text{ NOZ} \times 495}$  or  $\frac{GPA \times MPH \times \text{Nozzle Spacing}^*}{5940}$
- g. Length of Swath Run  $= MPH \times \text{Seconds Traveled} \times 1.466$
- h. Min/Acre  $\frac{495}{MPH \times SW}$
- i. MPH  $= \frac{GPM \times 495}{GPA \times SW}$
- j. MPH  $= \frac{0.682 \times \text{Distance Traveled}}{\text{Seconds}}$
- k. PSI  $= \frac{(GPA \times MPH \times SW)^2}{495 \times \# \text{ NOZ} \times \text{GPM/NOZ at 30 PSI}} \times 30$
- l. Swath Runs/Load  $= \frac{\text{Acre Load in Hopper}}{\text{Acres per Swath Run}}$
- m. Swath Runs/Load  $= \frac{\# \text{ Gal in Hopper}}{\# \text{ GPA} \times \text{Acre/Swath Run}}$
- n. Swath Runs/Load  $= \frac{\text{Acre Load in Hopper} \times 43560}{\text{Field Length} \times \text{Swath Width}}$
- o. TIME/Load  $= \frac{495 \times \# \text{ Gal per Load}}{GPA \times SW \times MPH}$

\* Use only if SW is same as boom width.

p. TIME/Swath =  $\frac{60 \times \text{Length of Run}}{\text{MPH} \times 5280}$        $\frac{\text{Length of Run} \times 0.01136}{\text{MPH}}$

q. TIME/Swath =  $\frac{60 \times 60 \times \text{Length of Run}}{\text{MPH} \times 5280}$  or  $\frac{\text{Length of Run} \times 0.68182}{\text{MPH}}$

PSI	CONVERSION NUMBER	PSI	CONVERSION NUMBER	PSI	CONVERSION NUMBER
1	.183	51	1.30	110	1.91
2	.258	52	1.32	120	2.00
3	.316	53	1.33	130	2.08
4	.365	54	1.34	140	2.16
5	.408	55	1.35	150	2.24
6	.447	56	1.37	160	2.31
7	.483	57	1.38	170	2.38
8	.516	58	1.39	180	2.45
9	.548	59	1.40	190	2.52
10	.577	60	1.41	200	2.58
11	.606	61	1.43	210	2.65
12	.633	62	1.44	220	2.71
13	.658	63	1.45	230	2.77
14	.683	64	1.46	240	2.83
15	.707	65	1.47	250	2.89
16	.730	66	1.48	260	2.94
17	.753	67	1.49	270	3.00
18	.775	68	1.51	280	3.06
19	.796	69	1.52	290	3.11
20	.817	70	1.53	300	3.16
21	.837	71	1.54	325	3.29
22	.856	72	1.55	350	3.42
23	.876	73	1.56	375	3.54
24	.894	74	1.57	400	3.65
25	.913	75	1.58	425	3.76
26	.931	76	1.59	450	3.87
27	.949	77	1.60	475	3.98
28	.966	78	1.61	500	4.08
29	.983	79	1.62	550	4.28
30	1.00	80	1.63	600	4.47
31	1.02	81	1.64	650	4.65
32	1.03	82	1.65	700	4.83
33	1.05	83	1.66	750	5.00
34	1.07	84	1.67	800	5.16
35	1.08	85	1.68	850	5.32
36	1.10	86	1.69	900	5.48
37	1.11	87	1.70	950	5.63
38	1.13	88	1.71	1000	5.77
39	1.14	89	1.72		
40	1.16	90	1.73		
41	1.17	91	1.74		
42	1.18	92	1.75		
43	1.20	93	1.76		
44	1.21	94	1.77		
45	1.23	95	1.78		
46	1.24	96	1.79		
47	1.25	97	1.80		
48	1.27	98	1.81		
49	1.28	99	1.82		
50	1.29	100	1.83		

SPRAYING SYSTEMS COMPANY

Nozzle	GPM*	Nozzle	GPM*	Nozzle	GPM	Nozzle	GPM
D-	1-13	.059	D-	1-46	.127		
D-	1.5-13	.067	D-	1.5-56	.185		
D -	2-13	.075	D -	2-56	.21		
D -	3-13	.08	D -	3-56	.29		
D-	4-13	.11	D-	4-56	.48		
			D -	5-56	.66		
			D -	6-56	.95		
D -	1-23	.064	D -	7-56	1.32		
D -	1.5-23	.076	D -	8-56	1.67		
D -	2-23	.092	D -	10-56	2.34		
D -	3-23	.10					
D-	4-23	.14					
D-	5-23	.16	D -	1-31	.13		
D-	6-23	.19	D-	1.5-31	.17		
			D-	2-31	.19		
			D -	3-31	.21		
D-	1-25	.088					
D-	1.5-25	.118	D-	1-33	.12		
D-	2-25	.14	D-	1.5-33	.17		
D-	3-25	.17	D-	2-33	.21		
D-	4-25	.25	D -	3-33	.25		
D -	5-25	.30	D-	4-33	.34		
D-	6-25	.39					
D-	7-25	.45					
D-	8-25	.53	D-	1-35	.13		
D-	10-25	.65	D-	1.5-35	.17		
D'	12-25	.80	D -	2-35	.24		
D -	14-25	.88	D -	3-35	.26		
			D-	4-35	.44		
D -	1-45	.108	D-	5-35	.58		
D-	1.5-45	.14					
D-	2-45	.18	D -	2	.242		
D -	3-45	.20	D -	3	.304		
D -	4-45	.31	D-	4	.479		
D-	5-45	.39	D-	5	.708		
D-	6-45	.50	D -	6	.996		
D -	7-45	.59	D-	7	1.25		
D-	8-45	.72	D-	8	1.50		
D-	10-45	.94	D-	10	2.35		
D-	12-45	1.17	D-	12	2.85		
D-	14-45	1.32	D-	14	3.10		
D-	16-45	1.54	D-	16	3.25		
D-	1-46	.126					
D-	1.5-46	.184					
D-	2-46	.24					
D-	3-46	.28					
D-	4-46	.48					
D-	5-46	.66					
D-	6-46	.95					
D-	7-46	1.22					
D-	8-46	1.59					
D-	10-46	2.15					
D-	12-46	2.71					

This information has been printed with the permission of Spray Systems Company. Their cooperation is greatly appreciated.

\*GPM/Noz at 30 PSI



SPRAYING SYSTEMS COMPANY

Nozzle	GPM*	Nozzle	GPM*	Nozzle	GPM*	Nozzle	GPM**
0003	.258	650067	.06	8040	3.5	2-25015	.260
0004	.346	6501	.09	8050	4.3	2-2502	.346
0006	.500	75015	.13	8060	5.2	2-2503	.520
0008	.708	6502	.17	8070	6.1		
0010	.875	6503	.26	80100	8.6		
0015	1.29	6504	.35	80150	13.0	4916-08	.007
0020	1.75	6505	.43	80200	17.3	10	.011
0030	2.83	6505	.52	80250	21.6	12	.017
0040	3.46	6508	.69	80300	26.0	14	.022
		6510	.86			15	.025
		6515	1.30			16	.028
1530	2.6	6520	1.73	9530	2.6	18	.036
1540	3.5	6530	2.6	9540	3.5	20	.045
1550	4.3	6540	3.5	9550	4.3	22	.054
1560	5.2	6550	4.3	9560	5.2	24	.064
1570	6.1	6560	5.2	9570	6.1	25	.069
		6570	6.1		26		.076
		65100	8.6		27		.079
2530	2.6	65150	13.0	11010	.86	28	.085
2540	3.5	65200	17.3	11015	1.3	29	.093
2550	4.3	65250	21.6			30	.099
2560	5.2	65300	26.0			31	.107
2570	6.1			150015	.13	32	.116
		730039	.034	15002	.17	34	.128
4030	2.6	750077	.067	15003	.26	35	.136
4040	3.5	630116	.10	15004	.35	37	.149
4050	4.3	730154	.13	15006	.52	39	.165
4060	5.2	730231	.20	15008	.69	40	.17
4070	6.1	730308	.27	15009	.78	41	.182
		730385	.33			43	.199
		730462	.40	8001E	.09	45	.216
5010	.833	730616	.53	80015E	.13	46	.233
5020	1.71	730770	.67	8002E	.17	47	.239
5030	2.6	730924	.80	8003E	.26	48	.249
5040	3.5			8004E	.35	49	.255
5050	4.3			8005E	.43	51	.286
5060	5.2	800067	.06	8006E	.52	52	.29C
5070	6.1	80001	.08	8008E	.69	54	.314
50100	8.6	80015	.13	8010E	.87	55	.325
50150	13.0	8002	.17	8015E	1.30	57	.348
50200	17.3	8003	.26			59	.375
50250	21.6	8004	.35			61	.405
50300	26.0	8005	.43	9501 E	.09	63	.425
		8006	.52	95015E	.13	65	.45
		8008	.69	9502E	.17	67	.48
		8010	.86	9503E	.26	69	.497
		8015	1.30	9504E	.35	70	.53
		8020	1.73	9505E	.43	72	.55
		8030	2.6	9506E	.52	73	.57
				9508E	.69	75	.604
				9510E	.87	78	.667
				9515E	1.30	80	.690
						81	.71

\*GPM/Noz at 30 PSI

SPRAYING SYSTEMS COMPANY

Nozzle	GPM*	Nozzle	GPM*	Nozzle	GPM*	Nozzle	GPM**
4916- 83	.75	K 27	4.7	KLC 5	.9	TG 1	.165
86	.81	K 30	5.1	KLC 9	1.6	TG 2	.329
89	.849	K 35	6.1	KLC 18	3.1	TG 3	.494
91	.909	K 40	6.9	KLC 36	6.3	TG 5	.823
93	.95	K 45	7.8	KLC 50	8.7		
95	.994	K 50	8.7	KLC 72	12.5		
98	1.09	K 60	10.4	KLC 108	18.7	FJ 0006	.521
103	1.13	K 70	12.1			FJ 0008	.692
107	1.27	K 80	13.8			FJ 0010	.875
110	1.35	K 90	15.6	DOC 14	1.2	FJ 0015	1.29
115	1.49	K 100	17.3	DOC 21	1.8	FJ 0020	1.75
120	1.55	K 110	19.0	DOC 32	2.8	FJ 0025	2.17
125	1.70	K 120	20.8	DOC 48	4.15	FJ 0030	2.58
128	1.77	K 180	31.1	DOC 72	6.25		
132	1.90	K 210	36.3			SS 5- 5W	.865
136	2.0	K 300	52.0			SS 10-10W	1.75
140	2.19	K 450	78.0	OC 02	.17		
144	2.3			OC 03	.26	FJ 8003	.260
147	2.34			OC 04	.35	FJ 8004	.346
151	2.5	KSS 1	.176	OC 06	.52	FJ 8005	.433
156	2.7	K SS 1.5	.264	OC 10	.87	FJ 8006	.520
161	2.8	K SS 2	.352	OC 12	1.0		
166	2.98	K SS 2.5	.429	OC 16	1.4		
170	3.2	K SS 3	.517	OC 20	1.7		
171	3.27	K SS 4	.693	OC 40	3.5		
172	3.33	K SS 5	.869	OC 80	7.0		
177	3.46	K SS 7.5	1.32	OC 150	13.0		
182	3.6	K SS 10	1.76	OC 300	26.0		
187	3.83	K SS 15	2.64				
196	4.3	K SS 18	3.08				
205	4.62	K SS 20	3.52	DDOC 28	2.4		
218	5.18	K SS 30	5.17	DDOC 42	3.6		
234	6.0	K SS 35	6.05	DDOC 64	5.6		
250	6.93	K SS 40	6.93	DDOC 96	8.3		
		K SS 45	7.81	DDOC 144	12.5		
		K SS 50	8.69				
K .25	.04	K SS 60	10.5	SS 80015	.13		
K .50	.08	K SS 70	12.2	SS 8002	.17		
K .75	.13	K SS 80	14.0	SS 8003	.26		
K 1	.17	K SS 90	15.6	SS 8004	.35		
K 1.5	.26	K SS 100	17.4	SS 8006	.52		
K 2	.35	K SS 110	19.1	SS 8008	.69		
K 2.5	.43	K SS 120	20.9	SS 8010	.86		
K 3	.52	K SS 180	31.9	SS 8015	1.30		
K 4	.69	K SS 210	36.3	SS 8020	1.73		
K 5	.87	K SS 300	51.7	SS 8030	2.60		
K 7.5	1.3			SS 8040	3.5		
K 10	1.7			SS 8050	4.3		
K 12	2.1			SS 8060	5.2		
K 15	2.6			SS 8070	6.1		
K 18	3.1						
K 20	3.5						
K 22	3.8						
K 24	4.2						

\*GPM/Noz at 30 PSI

SPRAYING SYSTEMS COMPANY

Nozzle	GPM*	Nozzle	GPM*
DTC - 2 13 HSS	.060	131 DDTC - 2 25 TC	.139
- 3 13	.067	- 3 25	.165
- 4 13	.090	- 4 25	.251
		- 5 25	.303
DTC - 2 23 HSS	.075	- 6 25	.381
- 3 23	.090	- 7 25	.450
- 4 23	.112	- 8 25	.528
- 5 23	.135	- 10 25	.658
- 6 23	.157		
		131 DDTC -2 45 TC	.173
DTC - 2 25 HSS	.120	- 3 45	.199
- 3 25	.142	- 4 45	.312
- 4 25	.217	- 5 45	.390
- 5 25	.262	- 6 45	.502
- 6 25	.330	- 7 45	.589
- 7 25	.390	- 8 45	.727
- 8 25	.457	- 10 45	.953
DTC - 2 45 HSS	.150	131 DDTC -2 46 HSS	.234
- 3 45	.172	- 3 46	.277
- 4 45	.270	- 4 46	.485
- 5 45	.337	- 5 46	.667
- 6 45	.435	- 6 46	.953
- 7 45	.510	- 7 46	1.20
- 8 45	.630	- 8 46	1.59
		- 10 46	2.15
DTC - 2 46 HSS	.202		
- 3 46	.240		
- 4 46	.420		
- 5 46	.577		
- 6 46	.825		
- 7 46	1.04		
- 8 46	1.38		
131 DDTC -2 13 TC	.069		
- 3 13	.078		
- 4 13	.104		
131 DDTC -2 23 TC	.087		
- 3 23	.104		
- 4 23	.130		
- 5 23	.156		
- 6 23	.182		
131 DDTC -2 24TC	.113		
- 3 24	.139		
- 4 24	.191		
- 5 24	.234		
- 6 24	.286		
- 7 24	.338		
- 8 24	.381		
- 10 24	.502		
- 12 24	.572		

\*GPM/Noz at 30 PSI

SPRAYING SYSTEMS COMPANY

Nozzle		GPM*
Y	1	.014
Y	1.5	.022
X	2	.030
X	3	.045
X	4	.058
X	6	.087
TX	1	.014
TX	2	.029
TX	3	.043
TX	4	.058
TX	6	.087
TX	8	.115
TX	10	.144
TX	12	.173
TX	18	.260
TX	26	.375
A	25	4.29
A	30	5.21
A	40	6.92
A	50	8.73

\*GPM/Noz at 30 PSI

DE LAVAN

Nozzle	GPM*	Nozzle	GPM*
LF- .4	.035	DC 2-13	.066
LF- .5	.043	DC 2-23	.088
LF-- .67	.060	DC 3-23	.099
LF - 1	.087	DC 2-25	.137
LF-- 1.5	.130	DC 3-25	.159
LF - 2	.17	DC 3-45	.197
LF-- 3	.26	DC 4-25	.246
LF - 4	.35	DC 5-25	.296
LF - 5	.43	DC 5-45	.389
LF - 6	.52	DC 7-25	.444
LF - 8	.69	DC 6-45	.509
LF-- 10	.86	DC 7-45	.608
LF - 15	1.3	DC 5-46	.685
LF - 20	1.7	DC 8-45	.739
		DC 12-25	.805
		DC 14-25	.904
LF - .39	.034	DC 6-46	.948
LF - .77	.067	DC 12-45	1.20
LF-- 1.16	.10	DC 7-56	1.31
LF - 1.54	.13	DC 8-46	1.60
LF - 2.31	.20	DC 8-56	1.67
LF - 3.08	.27	DC 10-46	2.17
LF - 3.85	.33		
LF - 4.62	.40	2 LF -1.5	.13
LF - 6.16	.53	2 LF- 2	.17
LF-- 7.70	.67	2 LF- 3	.26
LF - 9.24	.80	2 LF - 4	.35
LF - 15.5	1.4	1 LF--5	.43
		2 LF - 6	.52
RD - 1	.16	2 LF --8	.69
RD - 2	.25	2 LF - 9	.78
RD - 3	.30		
RD - 4	.39	WR- 2 or WRW- 2	.17
RD - 5	.50	WR- 4 or WRW- 4	.35
RD - 6	.59	WRW- 5	.43
RD - 7	.72	WR- 6 or WRW- 6	.52
RD - 8	.94	WR-10 or WRW-10	.86
RD - 9	1.17	WR-15 or WRW-15	1.30
RD - 10	1.32	WR-20 or WRW-20	1.70
		WR-25 or WRW-25	2.10
RA - 2	.17	WRW-50	4.30
RA - 4	.35		
RA - 5	.43	D .5 or F .5	.087
RA-- 6	.52	D.75 or F .75	.13
RA - 8	.69	D 1 or F 1	.17
RA - 10	.87	D 1.5 or F 1.5	.26
		D 2 or F 2	.35
RA - 20	1.7	D 2. 5 or F 2.5	.43
RA - 30	2.6	D 3 or F 3	.52
RA - 50	4.3	D 4 or F 4	.69
RA - 80	6.9	D 5 or F 5	.87
RA-- 100	8.7	D 6	1.0
RA -- 160	13.9	D 7.5 or F 7.5	1.3
RA - 200	17.3		

This information has been printed with the permission of DeLavan Company Their cooperation is greatly appreciated.

DE LAVAN

	Nozzle	GPM*		Nozzle	GPM*
D 10	or F 10	1.7		HB- 1 or HC- 1	.014
	F 12	2.1		HB- 1.25 or HC- 1.25	.019
D 15	or F 15	2.6		HB- 1.5 or HC- 1.5	.022
D 18	or F 18	3.1		HB- 2 or HC- 2	.029
D 20	or F 20	3.5		HB- 2.5 or HC- 2.5	.036
D 30	or F 30	5.2		HB- 3 or HC- 3	.043
	F 35	6.1		HB- 4 or HC- 4	.058
	F 40	6.9		HB- 5 or HC- 5	.072
	F 45	7.8		HB- 6 or HC- 6	.087
	F 50	8.7		HB- 8 or HC- 8	.115
	F 60	10.4		HB-10 or HC-10	.144
	F 70	12.1		HB-12 or HC-12	.173
	F 80	13.9		HB-14 or HC-14	.202
	F 90	15.6		HB-18 or HC-18	.260
	F100	17.3		HB-22 or HC-22	.318
	F108	18.7		HB-26 or HC-26	.375
	F120	20.8			
	F150	26.0		CE- 1	.17
	F180	31.2		CE- 2	.35
	F200	34.6		CE- 3	.52
	F210	36.4		CE- 4	.69
				CE- 5	.87
	LX- 2	.17		WFF-1.5 or WFM-1.5	.13
	LX- 3	.26		WFF-2 or WFM-2	.17
	LX- 4	.35		WFF-3 or WFM-3	.26
	LX- 6	.52		WFF-4 or WFM-4	.35
	LX- 8	.69		WFF-5 or WFM-5	.43
	LX-12	1.0		WFF-6 or WFM-6	.52
	LX-16	1.4		WFF-8 or WFM-8	.69
	LE- 1	.087		WFM-10	.86
	LE- 1.5	.13		WFM-12	1.00
	LE- 2	.17		WFM-15	1.30
	LE- 3	.26		WFM-20	1.70
	LE- 4	.35		WFM-30	2.60
	LE- 5	.43		WFM-40	3.50
	LE- 6	.52		WFM-50	4.30
	LE- 8	.69		WFM-60	5.20
	LE-10	.87		WFM-70	6.10
	LE-15	1.3			
	HC- 2	.028		1505 - 8	.007
	HC- 2.5	.037		10	.011
	HC- 3	.044		12	.016
	HC- 4	.058		14	.022
	HC- 5	.072		15	.025
	HC- 6	.087		16	.028
	HC- 8	.115		17	.031
	HC-10	.144		18	.035
	HC-12	.173		19	.039
				20	.043

\*GPM/Noz at 30 PSI

DE LAVAN

Nozzle	GPM*	Nozzle	GPM*
1505- 22	.051	1505-140	2.18
24	.064	156	2.74
25	.069	177	3.50
26	.075	196	4.26
28	.089	218	5.38
29	.094	234	6.16
30	.100	250	7.00
32	.108		
34	.119		
35	.125		
37	.140		
39	.157		
41	.170		
43	.187		
45	.208		
46	.215		
47	.220		
48	.230		
49	.242		
51	.26		
52	.274		
54	.290		
55	.306		
57	.33		
59	.351		
61	.380		
63	.416		
65	.44		
67	.476		
68	.49		
70	.532		
72	.56		
73	.584		
75	.61		
78	.667		
80	.71		
81	.719		
83	.75		
86	.779		
89	.836		
91	.85		
93	.875		
95	.92		
98	1.01		
103	1.1		
107	1.21		
110	1.24		
115	1.4		
120	1.52		
125	1.80		

\*GPM/Noz at 30 PSI

**SPECIFIC GRAVITY CONVERSIONS**

To obtain Gallons Per Minute for solutions other than water multiply the normal GPM for water by the conversion factor.

<b>Solution Data Pounds/Gallon</b>	<b>Specific Gravity</b>	<b>Conversion Factor</b>
5.2	.62	1.26
5.5	.66	1.23
6.0	.72	1.17
6.5	.78	1.23
6.7	.80	1.11
7.0	.84	1.09
7.5	.90	1.05
7.7	.92	1.04
8.0	.96	1.02
8.1	.97	1.01
8.35	1.00	1.00
8.5	1.02	.98
8.7	1.04	.97
9.0	1.08	.95
9.3	1.11	.95
9.5	1.14	.93
9.9	1.18	.92
10.0	1.20	.91
10.3	1.23	.90
10.5	1.26	.89
10.7	1.28	.88
10.8	1.29	.87
11.0	1.32	.86
11.3	1.35	.85
11.4	1.37	.85
11.5	1.38	.85
11.8	1.41	.84
12.0	1.44	.83
13.0	1.55	.80
14.0	1.68	.76
15.0	1.80	.75
16.0	1.90	.72
17.0	2.00	.70



ACRE/SWATH CHART

50 Foot Swath

Feet of Swath Run	Miles	Acres per Swath	Seconds per Swath Run																	
			Miles per Hour																	
			55	60	65	70	75	80	85	90	95	100	105	110	115	120	125	130	130	140
660	1/8	.76	8.2	7.5	6.9	6.4	6.0	5.6	5.3	5.0	4.7	4.5	4.3	4.1	3.9	3.7	3.6	3.5	3.3	3.2
1320	1/4	1.52	16.4	15.0	13.8	12.9	12.0	11.2	10.6	10.0	9.5	9.0	8.6	8.2	7.8	7.5	7.2	6.9	6.7	6.4
1980	3/8	2.27	24.5	22.5	20.8	19.3	18.0	16.9	15.9	15.0	14.2	13.5	12.9	12.3	11.7	11.2	10.8	10.4	10.0	9.6
2640	1/2	3.03	32.7	30.0	27.7	25.7	24.0	22.5	21.2	20.0	18.9	18.0	17.1	16.4	15.6	15.9	14.4	13.8	13.3	12.9
3300	5/8	3.79	40.9	37.5	34.6	32.1	30.0	28.1	26.5	25.0	23.7	22.5	21.4	20.5	19.6	18.7	18.0	17.3	16.7	16.1
3960	3/4	4.55	49.1	45.0	41.5	38.6	36.0	33.7	31.8	30.0	28.4	27.0	25.7	24.5	23.5	22.5	21.6	20.8	20.0	19.3
4620	7/8	5.30	57.3	52.5	48.5	45.0	42.0	39.4	37.1	35.0	33.2	31.5	30.0	28.6	27.4	26.4	25.2	24.2	23.3	22.5
528	.1	.61	6.5	6.0	5.5	5.1	4.8	4.5	4.2	4.0	3.8	3.6	3.4	3.3	3.1	3.0	2.9	2.8	2.7	2.6
1056	.2	1.21	13.1	12.0	11.1	10.3	9.6	9.0	8.5	8.0	7.6	7.2	6.7	6.5	6.8	6.0	5.8	5.5	5.3	5.1
1584	.3	1.82	19.6	18.0	16.6	15.4	14.4	13.5	12.7	12.0	11.4	10.8	10.3	9.8	9.4	9.0	8.6	8.3	8.0	7.7
2112	.4	2.42	26.2	24.0	22.2	20.6	19.2	18.0	16.9	16.0	15.2	14.4	13.7	13.1	12.5	12.0	11.5	11.1	10.7	10.3
2640	.5	3.03	32.7	30.0	27.7	25.7	24.0	22.5	21.2	20.0	18.9	18.0	17.1	16.4	15.6	15.0	14.4	13.8	13.3	12.9
3168	.6	3.64	39.3	36.0	33.3	30.9	28.8	27.0	25.4	24.0	22.7	21.6	20.6	19.6	18.8	18.0	17.3	16.6	16.0	15.4
3696	.7	4.24	45.8	42.0	38.8	36.0	33.6	31.5	29.6	28.0	26.5	25.2	24.0	22.9	21.0	21.0	20.2	19.4	18.7	18.0
4224	.8	4.85	52.4	48.0	44.3	41.1	38.4	36.0	33.9	32.0	30.3	28.8	27.4	26.2	25.0	24.0	23.0	22.2	21.3	20.6
4752	.9	5.45	58.9	54.0	49.9	46.3	43.2	40.5	38.1	36.0	34.1	32.4	30.9	29.5	28.2	27.0	25.9	24.9	24.0	23.2
5280	1.0	6.06	65.5	60.0	55.4	51.4	48.0	45.0	42.4	40.0	37.9	36.0	34.3	32.7	31.3	30.0	28.8	27.7	26.7	25.7
600	.69	7.4	6.8	6.3	5.8	5.5	5.1	4.8	4.5	4.3	4.1	3.9	3.7	3.6	3.4	3.3	3.1	3.0	2.9	
700	.80	8.7	8.0	7.3	6.8	6.4	6.0	5.6	5.3	5.0	4.8	4.5	4.3	4.2	4.0	3.8	3.7	3.5	3.4	
800	.92	9.9	9.1	8.4	7.8	7.3	6.8	6.4	6.1	5.7	5.5	5.2	5.0	4.7	4.5	4.4	4.2	4.0	3.9	
900	1.03	11.2	10.2	9.4	8.8	8.2	7.7	7.2	6.8	6.5	6.1	5.8	5.6	5.3	5.1	4.9	4.7	4.5	4.4	
1000	1.15	12.4	11.4	10.5	9.7	9.1	8.5	8.0	7.6	7.2	6.8	6.5	6.2	5.9	5.7	5.5	5.2	5.1	4.0	
1100	1.26	13.6	12.5	11.5	10.7	10.0	9.4	8.8	8.3	7.9	7.5	7.1	6.8	6.5	6.3	6.0	5.8	5.6	5.4	
1200	1.38	14.9	13.5	12.6	11.7	10.9	10.2	9.6	9.1	8.6	8.2	7.8	7.4	7.1	6.8	6.5	6.3	6.1	5.8	
1300	1.49	16.1	14.8	13.6	12.7	11.8	11.1	10.4	9.8	9.3	8.9	8.4	8.1	7.7	7.4	7.1	6.8	6.6	6.3	
1400	1.61	17.4	15.9	14.7	13.6	12.7	11.9	11.2	10.6	10.0	9.5	9.1	8.7	8.3	8.0	7.6	7.3	7.1	6.8	
1500	1.72	18.6	17.0	15.7	14.6	13.6	12.8	12.0	11.4	10.8	10.2	9.7	9.3	8.9	8.5	8.2	7.9	7.6	7.3	
1600	1.84	19.8	18.2	16.8	15.6	14.5	13.6	12.8	12.1	11.5	10.9	10.4	9.9	9.5	9.1	8.7	8.4	8.1	7.8	
1700	1.95	21.1	19.3	17.8	16.6	15.5	14.5	13.6	12.9	12.2	11.6	11.0	10.5	10.1	9.7	9.3	8.9	8.6	8.3	
1800	2.07	22.3	20.5	18.9	17.5	16.4	15.3	14.4	13.6	12.9	12.3	11.7	11.2	10.7	10.2	9.8	9.4	9.1	8.8	
1900	2.18	23.6	21.6	19.9	18.5	17.3	16.2	15.2	14.4	13.6	13.0	12.3	11.8	11.3	10.8	10.4	10.0	9.6	9.3	
2000	2.30	24.8	22.7	21.0	19.5	18.2	17.0	16.0	15.2	14.4	13.6	13.0	12.4	11.9	11.4	10.9	10.5	10.1	9.7	
2100	2.41	26.0	23.9	22.0	20.5	19.1	17.9	16.8	15.9	15.1	14.3	13.6	13.0	12.5	11.9	11.5	11.0	10.6	10.2	
2200	2.53	27.3	25.0	23.1	21.4	20.0	18.8	17.6	16.7	15.8	15.0	14.3	13.6	13.0	12.5	12.0	11.5	11.1	10.7	
2300	2.64	28.5	26.1	24.1	22.4	20.9	19.6	18.4	17.4	16.5	15.7	14.9	14.3	13.6	13.1	12.5	12.1	11.6	11.2	
2400	2.75	29.8	27.3	25.2	23.4	21.8	20.5	19.3	18.2	17.2	16.4	15.6	14.9	14.2	13.6	13.1	12.6	12.1	11.7	
2500	2.87	31.0	28.4	26.2	24.4	22.7	21.3	20.1	18.9	17.9	17.0	16.2	15.5	14.8	14.2	13.6	13.1	12.6	12.2	
2600	2.98	32.2	29.5	27.3	25.3	23.6	22.2	20.9	19.7	18.7	17.7	16.9	16.1	15.4	14.8	14.2	13.6	13.1	12.7	
2700	3.10	33.5	30.7	28.3	26.3	24.5	23.0	21.7	20.5	19.4	18.4	17.5	16.7	16.0	15.3	14.7	14.2	13.6	13.1	
2800	3.21	34.7	31.8	29.4	27.3	25.5	23.9	22.5	21.2	20.1	19.1	18.2	17.4	16.6	15.9	15.3	14.7	14.1	13.6	
2900	3.33	36.0	33.0	30.4	28.2	26.4	24.7	23.3	22.0	20.8	19.8	18.8	18.0	17.2	16.5	15.8	15.2	14.6	14.1	
3000	3.44	37.2	34.1	31.5	29.2	27.3	25.6	24.1	22.7	21.5	20.5	19.5	18.6	17.8	17.0	16.4	15.7	15.2	14.6	
3100	3.56	38.4	35.2	32.5	30.2	28.2	26.4	24.9	23.5	22.2	21.1	20.1	19.2	18.4	17.6	16.9	16.3	15.7	15.1	
3200	3.67	39.7	36.4	33.6	31.2	29.1	27.3	25.7	24.2	23.0	21.8	20.8	19.8	19.0	18.2	17.5	16.8	16.2	15.6	
3300	3.79	40.9	37.5	34.6	32.1	30.0	28.1	26.5	25.0	23.7	22.5	21.4	20.5	19.6	18.8	18.9	17.3	16.7	16.1	
3400	3.90	42.1	38.6	35.7	33.1	30.9	29.0	27.3	25.8	24.4	23.2	22.1	21.1	20.2	19.3	18.5	17.8	17.2	16.6	
3500	4.02	43.4	39.8	36.7	34.1	31.8	29.8	28.1	26.5	25.1	23.9	22.7	21.7	20.8	19.9	19.1	18.4	17.7	17.0	
3600	4.13	44.6	40.9	37.8	35.1	32.7	30.7	28.9	27.3	25.8	24.5	23.4	22.3	21.3	20.5	19.6	18.9	18.2	17.5	
3700	4.25	45.9	42.0	38.8	36.0	33.6	31.5	29.7	28.0	26.6	25.2	24.0	22.9	21.9	21.0	20.2	19.4	18.7	18.0	
3800	4.36	47.1	43.2	39.9	37.0	34.5	32.4	30.5	28.8	27.3	25.9	24.7	23.6	22.5	21.6	20.7	19.9	19.2	18.5	
3900	4.48	48.3	44.3	40.9	38.0	35.5	33.2	31.3	29.5	28.0	26.6	25.3	24.2	23.1	22.2	21.3	20.5	19.7	19.0	
4000	4.59	49.6	45.5	42.0	39.0	36.4	34.1	32.1	30.3	28.7	27.3	26.0	24.8	23.7	22.7	21.8	21.0	20.2	19.5	
4100	4.71	50.8	46.6	43.0	39.9	37.3	34.9	32.9	31.1	29.4	28.0	26.6	25.4	24.3	23.3	22.4	21.5	20.7	20.0	
4200	4.82	52.1	47.7	44.1	40.9	38.2	35.8	33.7	31.8	30.1	28.6	27.3	26.0	24.9	23.9	22.9	22.0	21.2	20.5	
4300	4.94	53.3	48.9	45.1	41.9	39.1	36.6	34.5	32.6	30.9	29.3	27.9	26.7	25.5	24.4	23.5	22.6	21.7	20.9	
4400	5.05	54.5	50.0	46.2	42.9	40.0	37.5	35.3	33.3	31.6	30.0	28.6	27.3	26.1	25.0	24.0	23.1	22.2	21.4	
4500	5.17	55.8	51.1	47.2	43.8	40.9	38.4	36.1	34.1	32.3	30.7	29.2	27.9	26.7	25.6	24.5	23.6	22.7	21.9	
4600	5.28	57.0	52.3	48.3	44.8	41.8	39.2	36.9	34.8	33.0	31.4	29.9	28.5	27.3	26.1	25.1	24.1	23.2	22.4	
4700	5.39	58.3	53.4	49.3	45.8	42.7	40.1	37.7	35.6	33.7	32.0	30.5	29.1	27.9	26.7	25.6	24.7	23.7	22.9	
4800	5.51	59.5	54.5	50.3	46.8	43.6	40.9	38.5	36.4	34.4	32.7	31.2	29.8	28.5	27.3	26.2	25.2	24.2	23.4	
4900	5.62	60.7	55.7	51.4	47.7	44.5	41.8	39.3	37.1	35.2	33.4	31.8	30.4	29.1	28.8	26.7	25.7	24.7	23.9	
5000	5.74	62.0	56.8	52.4	48.7	45.5	42.6	40.1	37.9	35.9	34.1	32.5	31.0	29.6	28.4	27.3	26.2	25.3	24.4	
5100	5.85	63.2	58.0	53.5	49.7	46.4	43.5	40.9	38.6	36.6	34.8	33.1	31.6	30.2	29.0	27.8	26.7	25.8	24.8	
5200	5.97	64.5	59.1	54.5	50.6	47.3	44.3	41.7	39.4	37.3	35.5	33.8	32.2	30.8	29.5	28.4	27.3	26.3	25.3	
5300	6.08	65.7	60.2	55.6	51.6	48.2														

ACRE/SWATH CHART

50 Foot Swath

Feet of Swath Run	Seconds per Swath Run																			
	Miles	Acres per Swath	Miles per Hour																	
			55	60	65	70	75	80	85	90	95	100	105	110	115	120	125	130	130	140
660	1/8	.90	8.2	7.5	6.9	6.4	6.0	5.6	5.3	5.0	4.7	4.5	4.3	4.1	3.9	3.7	3.6	3.5	3.3	3.2
1320	1/4	1.82	16.4	15.0	13.8	12.9	12.0	11.2	10.6	10.0	9.5	9.0	8.6	8.2	7.8	7.5	7.2	6.9	6.7	6.4
1980	3/8	2.73	24.5	22.5	20.8	19.3	18.0	16.9	15.9	15.0	14.2	13.5	12.9	12.3	11.7	11.2	10.8	10.4	10.0	9.6
2640	1/2	3.64	32.7	30.0	27.7	25.7	24.0	22.5	21.2	20.0	18.9	18.0	17.1	16.4	15.6	15.0	14.4	13.8	13.3	12.9
3300	5/8	4.55	40.9	37.5	34.6	32.1	30.0	28.1	26.5	25.0	23.7	22.5	21.4	20.5	19.6	18.7	18.0	17.3	16.7	16.1
3960	3/4	5.45	49.1	45.0	41.5	38.6	36.0	33.7	31.8	30.0	28.4	27.0	25.7	24.5	23.5	22.5	21.6	20.8	20.0	19.3
4620	7/8	6.36	57.3	52.5	48.5	45.0	42.0	39.4	37.1	35.0	33.2	31.5	30.0	28.6	27.4	26.4	25.2	24.2	23.3	22.5
528	.1	.73	6.5	6.0	5.5	5.1	4.8	4.5	4.2	4.0	3.8	3.6	3.4	3.3	3.1	3.0	2.9	2.8	2.7	2.6
1056	.2	1.45	13.1	12.0	11.1	10.3	9.6	9.0	8.5	8.0	7.6	7.2	6.7	6.5	6.8	6.0	5.8	5.5	5.3	5.1
1584	.3	2.18	19.6	18.0	16.6	15.4	14.4	13.5	12.7	12.0	11.4	10.8	10.3	9.8	9.4	9.0	8.6	8.3	8.0	7.7
2112	.4	2.91	26.2	24.0	22.2	20.6	19.2	18.0	16.9	16.0	15.2	14.4	13.7	13.1	12.5	12.0	11.5	11.1	10.7	10.3
2640	.5	3.64	32.7	30.0	27.7	25.7	24.0	22.5	21.2	20.0	18.9	18.0	17.1	16.4	15.6	15.0	14.4	13.8	13.3	12.9
3168	.6	4.36	39.3	36.0	33.3	30.9	28.8	27.0	25.4	24.0	22.7	21.6	20.6	19.6	18.8	18.0	17.3	16.6	16.0	15.4
3696	.7	5.09	45.8	42.0	38.8	36.0	33.6	31.5	29.6	28.0	26.5	25.2	24.0	22.9	21.0	21.0	20.2	19.4	18.7	18.0
4224	.8	5.82	52.4	48.0	44.3	41.1	38.4	36.0	33.9	32.0	30.3	28.8	27.4	26.2	25.0	24.0	23.0	22.2	21.3	20.6
4752	.9	6.55	58.9	54.0	49.9	46.3	43.2	40.5	38.1	36.0	34.1	32.4	30.9	29.5	28.2	27.0	25.9	24.9	24.0	23.2
5280	1.0	7.27	65.5	60.0	55.4	51.4	48.0	45.0	42.4	40.0	37.9	36.0	34.3	32.7	31.3	30.0	28.8	27.7	26.7	25.7
600		.69	7.4	6.8	6.3	5.8	5.5	5.1	4.8	4.5	4.3	4.1	3.9	3.7	3.6	3.4	3.3	3.1	3.0	2.9
700		.80	8.7	8.0	7.3	6.8	6.4	6.0	5.6	5.3	5.0	4.8	4.5	4.3	4.2	4.0	3.8	3.7	3.5	3.4
800		.92	9.9	9.1	8.4	7.8	7.3	6.8	6.4	6.1	5.7	5.5	5.2	5.0	4.7	4.5	4.4	4.2	4.0	3.9
900		1.03	11.2	10.2	9.4	8.8	8.2	7.7	7.2	6.8	6.5	6.1	5.8	5.6	5.3	5.1	4.9	4.7	4.5	4.4
1000		1.15	12.4	11.4	10.5	9.7	9.1	8.5	8.0	7.6	7.2	6.8	6.5	6.2	5.9	5.7	5.5	5.2	5.1	4.0
1100		1.26	13.6	12.5	11.5	10.7	10.0	9.4	8.8	8.3	7.9	7.5	7.1	6.8	6.5	6.3	6.0	5.8	5.6	5.4
1200		1.38	14.9	13.5	12.6	11.7	10.9	10.2	9.6	9.1	8.6	8.2	7.8	7.4	7.1	6.8	6.5	6.3	6.1	5.8
1300		1.49	16.1	14.8	13.6	12.7	11.8	11.1	10.4	9.8	9.3	8.9	8.4	8.1	7.7	7.4	7.1	6.8	6.6	6.3
1400		1.61	17.4	15.9	14.7	13.6	12.7	11.9	11.2	10.6	10.0	9.5	9.1	8.7	8.3	8.0	7.6	7.3	7.1	6.8
1500		1.72	18.6	17.0	15.7	14.6	13.6	12.8	12.0	11.4	10.8	10.2	9.7	9.3	8.9	8.5	8.2	7.9	7.6	7.3
1600		1.84	19.8	18.2	16.8	15.6	14.5	13.6	12.8	12.1	11.5	10.9	10.4	9.9	9.5	9.1	8.7	8.4	8.1	7.8
1700		1.95	21.1	19.3	17.8	16.6	15.5	14.5	13.6	12.9	12.2	11.6	11.0	10.5	10.1	9.7	9.3	8.9	8.6	8.3
1800		2.07	22.3	20.5	18.9	17.5	16.4	15.3	14.4	13.6	12.9	12.3	11.7	11.2	10.7	10.2	9.8	9.4	9.1	8.8
1900		2.18	23.6	21.6	19.9	18.5	17.3	16.2	15.2	14.4	13.6	13.0	12.3	11.8	11.3	10.8	10.4	10.0	9.6	9.3
2000		2.30	24.8	22.7	21.0	19.5	18.2	17.0	16.0	15.2	14.4	13.6	13.0	12.4	11.9	11.4	10.9	10.5	10.1	9.7
2100		2.41	26.0	23.9	22.0	20.5	19.1	17.9	16.8	15.9	15.1	14.3	13.6	13.0	12.5	11.9	11.5	11.0	10.6	10.2
2200		2.53	27.3	25.0	23.1	21.4	20.0	18.8	17.6	16.7	15.8	15.0	14.3	13.6	13.0	12.5	12.0	11.5	11.1	10.7
2300		2.64	28.5	26.1	24.1	22.4	20.9	19.6	18.4	17.4	16.5	15.7	14.9	14.3	13.6	13.1	12.5	12.1	11.6	11.2
2400		2.75	29.8	27.3	25.2	23.4	21.8	20.5	19.3	18.2	17.2	16.4	15.6	14.9	14.2	13.6	13.1	12.6	12.1	11.7
2500		2.87	31.0	28.4	26.2	24.4	22.7	21.3	20.1	18.9	17.9	17.0	16.2	15.5	14.8	14.2	13.6	13.1	12.6	12.2
2600		2.98	32.2	29.5	27.3	25.3	23.6	22.2	20.9	19.7	18.7	17.7	16.9	16.1	15.4	14.8	14.2	13.6	13.1	12.7
2700		3.10	33.5	30.7	28.3	26.3	24.5	23.0	21.7	20.5	19.4	18.4	17.5	16.7	16.0	15.3	14.7	14.2	13.6	13.1
2800		3.21	34.7	31.8	29.4	27.3	25.5	23.9	22.5	21.2	20.1	19.1	18.2	17.4	16.6	15.9	15.3	14.7	14.1	13.6
2900		3.33	36.0	33.0	30.4	28.2	26.4	24.7	23.3	22.0	20.8	19.8	18.8	18.0	17.2	16.5	15.8	15.2	14.6	14.1
3000		3.44	37.2	34.1	31.5	29.2	27.3	25.6	24.1	22.7	21.5	20.5	19.5	18.6	17.8	17.0	16.4	15.7	15.2	14.6
3100		3.56	38.4	35.2	32.5	30.2	28.2	26.4	24.9	23.5	22.2	21.1	20.1	19.2	18.4	17.6	16.9	16.3	15.7	15.1
3200		3.67	39.7	36.4	33.6	31.2	29.1	27.3	25.7	24.2	23.0	21.8	20.8	19.8	19.0	18.2	17.5	16.8	16.2	15.6
3300		3.79	40.9	37.5	34.6	32.1	30.0	28.1	26.5	25.0	23.7	22.5	21.4	20.5	19.6	18.8	18.9	17.3	16.7	16.1
3400		3.90	42.1	38.6	35.7	33.1	30.9	29.0	27.3	25.8	24.4	23.2	22.1	21.1	20.2	19.3	18.5	17.8	17.2	16.6
3500		4.02	43.4	39.8	36.7	34.1	31.8	29.8	28.1	26.5	25.1	23.9	22.7	21.7	20.8	19.9	19.1	18.4	17.7	17.0
3600		4.13	44.6	40.9	37.8	35.1	32.7	30.7	28.9	27.3	25.8	24.5	23.4	22.3	21.3	20.5	19.6	18.9	18.2	17.5
3700		4.25	45.9	42.0	38.8	36.0	33.6	31.5	29.7	28.0	26.6	25.2	24.0	22.9	21.9	21.0	20.2	19.4	18.7	18.0
3800		4.36	47.1	43.2	39.9	37.0	34.5	32.4	30.5	28.8	27.3	25.9	24.7	23.6	22.5	21.6	20.7	19.9	19.2	18.5
3900		4.48	48.3	44.3	40.9	38.0	35.5	33.2	31.3	29.5	28.0	26.6	25.3	24.2	23.1	22.2	21.3	20.5	19.7	19.0
4000		4.59	49.6	45.5	42.0	39.0	36.4	34.1	32.1	30.3	28.7	27.3	26.0	24.8	23.7	22.7	21.8	21.0	20.2	19.5
4100		4.71	50.8	46.6	43.0	39.9	37.3	34.9	32.9	31.1	29.4	28.0	26.6	25.4	24.3	23.3	22.4	21.5	20.7	20.0
4200		4.82	52.1	47.7	44.1	40.9	38.2	35.8	33.7	31.8	30.1	28.6	27.3	26.0	24.9	23.9	22.9	22.0	21.2	20.5
4300		4.94	53.3	48.9	45.1	41.9	39.1	36.6	34.5	32.6	30.9	29.3	27.9	26.7	25.5	24.4	23.5	22.6	21.7	20.9
4400		5.05	54.5	50.0	46.2	42.9	40.0	37.5	35.3	33.3	31.6	30.0	28.6	27.3	26.1	25.0	24.0	23.1	22.2	21.4
4500		5.17	55.8	51.1	47.2	43.8	40.9	38.4	36.1	34.1	32.3	30.7	29.2	27.9	26.7	25.6	24.5	23.6	22.7	21.9
4600		5.28	57.0	52.3	48.3	44.8	41.8	39.2	36.9	34.8	33.0	31.4	29.9	28.5	27.3	26.1	25.1	24.1	23.2	22.4
4700		5.39	58.3	53.4	49.3	45.8	42.7	40.1	37.7	35.6	33.7	32.0	30.5	29.1	27.9	26.7	25.6	24.7	23.7	22.9
4800		5.51	59.5	54.5	50.3	46.8	43.6	40.9	38.5	36.4	34.4	32.7	31.2	29.8	28.5	27.3	26.2	25.2	24.2	23.4
4900		5.62	60.7	55.7	51.4	47.7	44.5	41.8	39.3	37.1	35.2	33.4	31.8	30.4	29.1	28.8	26.7	25.7	24.7	23.9
5000		5.74	62.0	56.8	52.4	48.7	45.5	42.6	40.1	37.9	35.9	34.1	32.5	31.0	29.6	28.4	27.3	26.2	25.3	24.4
5100		5.85	63.2	58.0	53.5	49.7	46.4	43.5	40.9	38.6	36.6	34.8	33.1	31.6	30.2	29.0	27.8	26.7	25.8	24.8
5200		5.97	64.5	59.1	54.5	50.6	47.3	44.3	41.7	39.4	37.3	35.5	33.8	32.2	30.8	29.5	28.4	27.3	26.3	25.3
5300		6.08	65.7	60.2	55.6	51.6	48.													

ACRE/SWATH CHART

50 Foot Swath

Feet of Swath Run	Miles	Acres per Swath	Seconds per Swath Run																	
			Miles per Hour																	
			55	60	65	70	75	80	85	90	95	100	105	110	115	120	125	130	130	140
660	1/8	1.06	8.2	7.5	6.9	6.4	6.0	5.6	5.3	5.0	4.7	4.5	4.3	4.1	3.9	3.7	3.6	3.5	3.3	3.2
1320	1/4	2.12	16.4	15.0	13.8	12.9	12.0	11.2	10.6	10.0	9.5	9.0	8.6	8.2	7.8	7.5	7.2	6.9	6.7	6.4
1980	3/8	3.18	24.5	22.5	20.8	19.3	18.0	16.9	15.9	15.0	14.2	13.5	12.9	12.3	11.7	11.2	10.8	10.4	10.0	9.6
2640	1/2	4.24	32.7	30.0	27.7	25.7	24.0	22.5	21.2	20.0	18.9	18.0	17.1	16.4	15.6	15.0	14.4	13.8	13.3	12.9
3300	5/8	5.30	40.9	37.5	34.6	32.1	30.0	28.1	26.5	25.0	23.7	22.5	21.4	20.5	19.6	18.7	18.0	17.3	16.7	16.1
3960	3/4	6.36	49.1	45.0	41.5	38.6	36.0	33.7	31.8	30.0	28.4	27.0	25.7	24.5	23.5	22.5	21.6	20.8	20.0	19.3
4620	7/8	7.42	57.3	52.5	48.5	45.0	42.0	39.4	37.1	35.0	33.2	31.5	30.0	28.6	27.4	26.4	25.2	24.2	23.3	22.5
528	.1	.85	6.5	6.0	5.5	5.1	4.8	4.5	4.2	4.0	3.8	3.6	3.4	3.3	3.1	3.0	2.9	2.8	2.7	2.6
1056	.2	1.70	13.1	12.0	11.1	10.3	9.6	9.0	8.5	8.0	7.6	7.2	6.7	6.5	6.8	6.0	5.8	5.5	5.3	5.1
1584	.3	2.55	19.6	18.0	16.6	15.4	14.4	13.5	12.7	12.0	11.4	10.8	10.3	9.8	9.4	9.0	8.6	8.3	8.0	7.7
2112	.4	3.39	26.2	24.0	22.2	20.6	19.2	18.0	16.9	16.0	15.2	14.4	13.7	13.1	12.5	12.0	11.5	11.1	10.7	10.3
2640	.5	4.24	32.7	30.0	27.7	25.7	24.0	22.5	21.2	20.0	18.9	18.0	17.1	16.4	15.6	15.0	14.4	13.8	13.3	12.9
3168	.6	5.09	39.3	36.0	33.3	30.9	28.8	27.0	25.4	24.0	22.7	21.6	20.6	19.6	18.8	18.0	17.3	16.6	16.0	15.4
3696	.7	5.94	45.8	42.0	38.8	36.0	33.6	31.5	29.6	28.0	26.5	25.2	24.0	22.9	21.0	21.0	20.2	19.4	18.7	18.0
4224	.8	6.79	52.4	48.0	44.3	41.1	38.4	36.0	33.9	32.0	30.3	28.8	27.4	26.2	25.0	24.0	23.0	22.2	21.3	20.6
4752	.9	7.64	58.9	54.0	49.9	46.3	43.2	40.5	38.1	36.0	34.1	32.4	30.9	29.5	28.2	27.0	25.9	24.9	24.0	23.2
5280	1.0	8.48	65.5	60.0	55.4	51.4	48.0	45.0	42.4	40.0	37.9	36.0	34.3	32.7	31.3	30.0	28.8	27.7	26.7	25.7
600	.69	7.4	6.8	6.3	5.8	5.5	5.1	4.8	4.5	4.3	4.1	3.9	3.7	3.6	3.4	3.3	3.1	3.0	2.9	
700	.80	8.7	8.0	7.3	6.8	6.4	6.0	5.6	5.3	5.0	4.8	4.5	4.3	4.2	4.0	3.8	3.7	3.5	3.4	
800	.92	9.9	9.1	8.4	7.8	7.3	6.8	6.4	6.1	5.7	5.5	5.2	5.0	4.7	4.5	4.4	4.2	4.0	3.9	
900	1.03	11.2	10.2	9.4	8.8	8.2	7.7	7.2	6.8	6.5	6.1	5.8	5.6	5.3	5.1	4.9	4.7	4.5	4.4	
1000	1.15	12.4	11.4	10.5	9.7	9.1	8.5	8.0	7.6	7.2	6.8	6.5	6.2	5.9	5.7	5.5	5.2	5.1	4.0	
1100	1.26	13.6	12.5	11.5	10.7	10.0	9.4	8.8	8.3	7.9	7.5	7.1	6.8	6.5	6.3	6.0	5.8	5.6	5.4	
1200	1.38	14.9	13.5	12.6	11.7	10.9	10.2	9.6	9.1	8.6	8.2	7.8	7.4	7.1	6.8	6.5	6.3	6.1	5.8	
1300	1.49	16.1	14.8	13.6	12.7	11.8	11.1	10.4	9.8	9.3	8.9	8.4	8.1	7.7	7.4	7.1	6.8	6.6	6.3	
1400	1.61	17.4	15.9	14.7	13.6	12.7	11.9	11.2	10.6	10.0	9.5	9.1	8.7	8.3	8.0	7.6	7.3	7.1	6.8	
1500	1.72	18.6	17.0	15.7	14.6	13.6	12.8	12.0	11.4	10.8	10.2	9.7	9.3	8.9	8.5	8.2	7.9	7.6	7.3	
1600	1.84	19.8	18.2	16.8	15.6	14.5	13.6	12.8	12.1	11.5	10.9	10.4	9.9	9.5	9.1	8.7	8.4	8.1	7.8	
1700	1.95	21.1	19.3	17.8	16.6	15.5	14.5	13.6	12.9	12.2	11.6	11.0	10.5	10.1	9.7	9.3	8.9	8.6	8.3	
1800	2.07	22.3	20.5	18.9	17.5	16.4	15.3	14.4	13.6	12.9	12.3	11.7	11.2	10.7	10.2	9.8	9.4	9.1	8.8	
1900	2.18	23.6	21.6	19.9	18.5	17.3	16.2	15.2	14.4	13.6	13.0	12.3	11.8	11.3	10.8	10.4	10.0	9.6	9.3	
2000	2.30	24.8	22.7	21.0	19.5	18.2	17.0	16.0	15.2	14.4	13.6	13.0	12.4	11.9	11.4	10.9	10.5	10.1	9.7	
2100	2.41	26.0	23.9	22.0	20.5	19.1	17.9	16.8	15.9	15.1	14.3	13.6	13.0	12.5	11.9	11.5	11.0	10.6	10.2	
2200	2.53	27.3	25.0	23.1	21.4	20.0	18.8	17.6	16.7	15.8	15.0	14.3	13.6	13.0	12.5	12.0	11.5	11.1	10.7	
2300	2.64	28.5	26.1	24.1	22.4	20.9	19.6	18.4	17.4	16.5	15.7	14.9	14.3	13.6	13.1	12.5	12.1	11.6	11.2	
2400	2.75	29.8	27.3	25.2	23.4	21.8	20.5	19.3	18.2	17.2	16.4	15.6	14.9	14.2	13.6	13.1	12.6	12.1	11.7	
2500	2.87	31.0	28.4	26.2	24.4	22.7	21.3	20.1	18.9	17.9	17.0	16.2	15.5	14.8	14.2	13.6	13.1	12.6	12.2	
2600	2.98	32.2	29.5	27.3	25.3	23.6	22.2	20.9	19.7	18.7	17.7	16.9	16.1	15.4	14.8	14.2	13.6	13.1	12.7	
2700	3.10	33.5	30.7	28.3	26.3	24.5	23.0	21.7	20.5	19.4	18.4	17.5	16.7	16.0	15.3	14.7	14.2	13.6	13.1	
2800	3.21	34.7	31.8	29.4	27.3	25.5	23.9	22.5	21.2	20.1	19.1	18.2	17.4	16.6	15.9	15.3	14.7	14.1	13.6	
2900	3.33	36.0	33.0	30.4	28.2	26.4	24.7	23.3	22.0	20.8	19.8	18.8	18.0	17.2	16.5	15.8	15.2	14.6	14.1	
3000	3.44	37.2	34.1	31.5	29.2	27.3	25.6	24.1	22.7	21.5	20.5	19.5	18.6	17.8	17.0	16.4	15.7	15.2	14.6	
3100	3.56	38.4	35.2	32.5	30.2	28.2	26.4	24.9	23.5	22.2	21.1	20.1	19.2	18.4	17.6	16.9	16.3	15.7	15.1	
3200	3.67	39.7	36.4	33.6	31.2	29.1	27.3	25.7	24.2	23.0	21.8	20.8	19.8	19.0	18.2	17.5	16.8	16.2	15.6	
3300	3.79	40.9	37.5	34.6	32.1	30.0	28.1	26.5	25.0	23.7	22.5	21.4	20.5	19.6	18.8	18.0	17.3	16.7	16.1	
3400	3.90	42.1	38.6	35.7	33.1	30.9	29.0	27.3	25.8	24.4	23.2	22.1	21.1	20.2	19.3	18.5	17.8	17.2	16.6	
3500	4.02	43.4	39.8	36.7	34.1	31.8	29.8	28.1	26.5	25.1	23.9	22.7	21.7	20.8	19.9	19.1	18.4	17.7	17.0	
3600	4.13	44.6	40.9	37.8	35.1	32.7	30.7	28.9	27.3	25.8	24.5	23.4	22.3	21.3	20.5	19.6	18.9	18.2	17.5	
3700	4.25	45.9	42.0	38.8	36.0	33.6	31.5	29.7	28.0	26.6	25.2	24.0	22.9	21.9	21.0	20.2	19.4	18.7	18.0	
3800	4.36	47.1	43.2	39.9	37.0	34.5	32.4	30.5	28.8	27.3	25.9	24.7	23.6	22.5	21.6	20.7	19.9	19.2	18.5	
3900	4.48	48.3	44.3	40.9	38.0	35.5	33.2	31.3	29.5	28.0	26.6	25.3	24.2	23.1	22.2	21.3	20.5	19.7	19.0	
4000	4.59	49.6	45.5	42.0	39.0	36.4	34.1	32.1	30.3	28.7	27.3	26.0	24.8	23.7	22.7	21.8	21.0	20.2	19.5	
4100	4.71	50.8	46.6	43.0	39.9	37.3	34.9	32.9	31.1	29.4	28.0	26.6	25.4	24.3	23.3	22.4	21.5	20.7	20.0	
4200	4.82	52.1	47.7	44.1	40.9	38.2	35.8	33.7	31.8	30.1	28.6	27.3	26.0	24.9	23.9	22.9	22.0	21.2	20.5	
4300	4.94	53.3	48.9	45.1	41.9	39.1	36.6	34.5	32.6	30.9	29.3	27.9	26.7	25.5	24.4	23.5	22.6	21.7	20.9	
4400	5.05	54.5	50.0	46.2	42.9	40.0	37.5	35.3	33.3	31.6	30.0	28.6	27.3	26.1	25.0	24.0	23.1	22.2	21.4	
4500	5.17	55.8	51.1	47.2	43.8	40.9	38.4	36.1	34.1	32.3	30.7	29.2	27.9	26.7	25.6	24.5	23.6	22.7	21.9	
4600	5.28	57.0	52.3	48.3	44.8	41.8	39.2	36.9	34.8	33.0	31.4	29.9	28.5	27.3	26.1	25.1	24.1	23.2	22.4	
4700	5.39	58.3	53.4	49.3	45.8	42.7	40.1	37.7	35.6	33.7	32.0	30.5	29.1	27.9	26.7	25.6	24.7	23.7	22.9	
4800	5.51	59.5	54.5	50.3	46.8	43.6	40.9	38.5	36.4	34.4	32.7	31.2	29.8	28.5	27.3	26.2	25.2	24.2	23.4	
4900	5.62	60.7	55.7	51.4	47.7	44.5	41.8	39.3	37.1	35.2	33.4	31.8	30.4	29.1	28.8	26.7	25.7	24.7	23.9	
5000	5.74	62.0	56.8	52.4	48.7	45.5	42.6	40.1	37.9	35.9	34.1	32.5	31.0	29.6	28.4	27.3	26.2	25.3	24.4	
5100	5.85	63.2	58.0	53.5	49.7	46.4	43.5	40.9	38.6	36.6	34.8	33.1	31.6	30.2	29.0	27.8	26.7	25.8	24.8	
5200	5.97	64.5	59.1	54.5	50.6	47.3	44.3	41.7	39.4	37.3	35.5	33.8	32.2	30.8	29.5	28.4	27.3	26.3	25.3	
5300	6.08	65.7	60.2	55.6	51.6	48.2</														

## APPENDIX H TORQUE LIMITS

Use the torque values listed in the maintenance procedures, if they are given. When no torque values are given in the maintenance procedures, use the following guides.

**Table H-1. Torque Value Guide (Pound-Feet)**

Screw Diameter	Torque Lb-Ft No Dashes (SAE Grade 2)	Torque Lb-Ft 3 Dashes (SAE Grade 5)	Torque Lb-Ft 6 Dashes (SAE Grade 8)	Socket Size
1/4-20 UNC	3-5	6-8	10-12	7/16
1/4-28 UNF	4-6	8-10	9-14	7/16
4/16-18 UNC	7-11	13-17	19-24	1/2
5/16-24 UNF	7-11	14-19	23-28	1/2
3/8-16 UNC	14-18	26-31	39-44	9/16
3/8-24 UNF	15-19	30-35	46-51	9/16
7/16-14 UNC	23-28	44-49	65-70	5/8
7/16-20 UNF	23-28	44-54	69-79	5/8
1/2-13 UNC	32-37	65-75	95-105	3/4
1/2-20 UNF	34-41	73-83	113-123	3/4
9/16-12 UNC	46-56	100-110	145-155	13/16
9/16-18 UNF	47-57	107-117	165-175	13/16
5/8-11 UNC	62-72	140-150	200-210	15/16
5/8-18 UNF	67-77	153-163	235-245	15/16
3/4-10 UNC	106-116	200-270	365-375	1-1/4
3/4-16 UNF	115-125	268-278	417-427	1-1/4
7/8-9 UNC	165-175	385-395	595-605	1-5/16
7/8-14 UNF	178-188	424-434	663-673	1-5/16
1-8 UNC	251-261	580-590	900-910	1-1/2
1-14 UNF	255-265	585-634	943-993	1-1/2
1-1/4-7 UNC	441-461	1070-1120	1767-1817	1-7/8
1-1/4-12 UNF	488-498	1211-1261	1963-2013	1-7/8
1-1/2-6 UNC	727-737	1899-1949	3111-3161	2-1/4
1-1/2-12 UNF	816-826	2144-2194	3506-3556	2-1/4

Table H-2. Torque Value Guide (Newton-Meters)

Screw Diameter	Torque N.n No Dashes (SAE Grade 2)	Torque N.m 3 Dashes (SAE Grade 5)	Torque Lb-N.m 6 Dashes (SAE Grade 8)	Socket Size
1/4-20 UNC	4-7	8-11	14-16	7/16
1/4-28 UNF	5-8	11-14	12-19	7/16
5/16-18 UNC	9-15	18-23	26-33	1/2
5/16-24 UNF	9-15	19-26	31-38	1/2
3/8-16 UNC	19-24	35-42	53-60	9/16
3/8-24 UNF	20-26	41-47	62-69	9/16
7/16-14 UNC	31-38	60-66	88-95	5/8
7/16-20 UNF	31-38	60-73	94-107	5/8
1/2-13 UNC	43-50	88-102	129-142	3/4
1/2-20 UNF	46-56	99-113	153-167	3/4
9/16-12 UNC	62-76	136-149	197-210	13/16
9/16-18 UNF	64-77	145-159	224-237	13/16
5/8-11 UNC	84-98	190-203	271-285	15/16
5/8-18 UNF	91-104	207-221	319-332	15/16
3/4-10 UNC	144-157	353-366	495-508	1-1/4
3/4-16 UNF	156-169	363-377	565-579	1-1/4
7/8-9 UNC	224-237	522-536	807-820	1-5/16
7/8-14 UNF	241-255	575-588	899-912	1-5/16
1-8 UNC	340-354	786-800	1220-1234	1-1/2
1-14 UNF	346-359	793-860	1279-1346	1-1/2
1-1/4-7 UNC	611-625	1451-1518	2396-2463	1-7/8
1-1/4-12 UNF	662-675	1642-1710	2661-2729	1-7/8
1-1/2-6 UNC	986-999	2575-2642	4218-4286	2-1/4
1-1/2-12 UNF	1106-1120	2907-2975	4753-4821	2-1/4

**GLOSSARY  
ABBREVIATIONS**

gpa.....	gallons per acre
k.....	kilogram
LV.....	low volume
NOZ.....	nozzle
PDU.....	Pesticide Dispersal Unit, Multicapability, Helicopter Slung
SD.....	solid dispersal
SW.....	swath width
ULV.....	ultra-low volume

INDEX

Subject	Paragraph, Figure, Table Number
<b>A</b>	
Acre/Swath Chart.....	G-4
Air Application Formulas .....	G-6
Air Cleaner Replacement/Repair.....	4-22
All Angle Isolator Replacement .....	4-30
Assembly of LV System.....	F 2-6
Assembly of SD System.....	F 2-8
Assembly of ULV System.....	F 2-7
Attaching PDU to Helicopter.....	2-11
<b>B</b>	
Battery Assembly Replacement.....	4-33
Battery Cable Replacement.....	4-31
Battery/Hydraulic Assembly Replacement.....	4-29
Battery Installation .....	F 2-5
Bucket Assembly Replacement.....	4-13
Bucket Harness Replacement.....	4-37
<b>C</b>	
Carburetor Replacement/Repair.....	4-21
Checking Unpacked Equipment .....	4-5
Common Tools and Equipment (Direct Support).....	5-1
Common Tools and Equipment (Unit) .....	4-1
Consolidated Index of Army Publications and Blank Forms.....	1-2
<b>D</b>	
Destruction of Army Materiel to Prevent Enemy Use.....	1-4
Direct Support Troubleshooting.....	T 5-1
Disassembly of LV System.....	F 2-15
Disassembly of SD System.....	F 2-17
Disassembly of ULV System.....	F 2-16
Dolly Assembly Repair.....	4-56
Dolly Assembly Replacement.....	4-55
Door Lid Assembly Repair.....	4-15
Door Lid Assembly Replacement.....	4-14
<b>E</b>	
Effective Swath Width.....	F 2-12
Emergency Operation .....	2-21
Engine and Pump Assembly Hydraulic Pump Repair.....	5-8
Engine and Pump Assembly Replacement.....	4-19
Engine and Pump Assembly Testing.....	4-18
Equipment Characteristics, Capabilities, and Features.....	1-9
Equipment Configuration.....	1-12
Equipment Data .....	1-11
Explanation of Columns (COEI and BII).....	C-3

INDEX

Subject	Paragraph, Figure, Table Number
<b>E (Cont)</b>	
Explanation of Columns (Expendable).....	E-2
Explanation of Columns in Remarks, Section IV.....	B-5
Explanation of Columns in the MAC, Section II.....	B-3
Explanation of Columns in Tool and Test Equipment Requirements, Section III.....	B-4
<b>F</b>	
Flow Rate - .....	T 2-6
Flying PDU to Mission Location.....	2-12
Forms .....	A-2
Fuel Strainer Petcock.....	F 2-4
Functional Description.....	1-14
<b>G</b>	
Gas Tank Assembly Replacement/Repair.....	4-28
General (COEI and BII).....	C-1
General (MAC).....	B-1
General (Operator).....	2-4
General (Unit) .....	4-6
General Assembly Instructions.....	1-20
General Cleaning Instructions.....	1-15
General Disassembly Instructions.....	1-19
General Inspection Instructions.....	1-16
General Removal Instructions.....	1-17
General Repair Instructions.....	1-18
<b>H</b>	
Hand Control Assembly.....	F 1-2
Hand Control Assembly/Electrical-Safety Cable Assembly Replacement.....	4-38
Hand Control Assembly Repair .....	5-11
Hand Control Switches and Indicators.....	F 2-1
Hand Control Switches and Indicators.....	T 2-1
Hand Control Switches and Indicators.....	2-1
Hand Signals.....	F 2-13
Helicopter/Lifting Strap Hookup.....	F 2-14
Hopper Assembly Repair.....	4-54
Hopper Assembly Replacement.....	4-53
Hydraulic Motor Repair.....	5-13
Hydraulic Pump Assembly Replacement.....	4-27
Hydraulic Reservoir Primary Manifold Assembly Repair.....	4-35
Hydraulic Reservoir Primary Manifold Assembly Replacement.....	4-34
Hydraulic System Controls and Indicators.....	2-2
Hydraulic System Gages and Control Knobs.....	F 2-2
Hydraulic System Gages and Controls.....	T 2-2
<b>I</b>	
Initial Adjustments and Tests.....	2-10
Introduction.....	4-12



INDEX

Subject	Paragraph, Figure, Table Number
<b>K</b>	
Key Switchbox Assembly Repair.....	5-5
Key Switchbox Assembly Replacement .....	4-20
<b>L</b>	
Landing PDU .....	2-14
Leakage Definitions (Operator) .....	2-6
Leakage Definitions (Unit).....	4-9
Location and Description of Major Components.....	1-10
Lubrication .....	3-1
LV Boom Assembly Replacement/Repair.....	4-46
LV Boom Pressure Assembly Adjustment.....	F 2-9
LV System Flow Rate - Water.....	T 2-5
<b>M</b>	
Maintenance Forms and Records.....	4-7
Maintenance Forms, Records, and Reports.....	1-3
Maintenance Functions.....	B-2
Miscellaneous Publications.....	A-4
Motor and Slinger Assembly Repair.....	4-52
Motor and Slinger Assembly Replacement.....	4-51
Muffler Assembly Repair.....	4-24
Muffler Assembly Replacement.....	4-23
<b>N</b>	
Nomenclature Cross-Reference List.....	1-6
Nozzle Selection .....	G-2
<b>O</b>	
Oil Fill and Drain Assembly Repair.....	4-26
Operation in Dusty or Sandy Areas .....	2-18
Operation in Extreme Heat.....	2-17
Operation in Salt Water Areas.....	2-20
Operation Under Rainy or Humid Conditions.....	2-19
Operator Level PMCS.....	T 2-4
Operator Troubleshooting.....	T 3-1
<b>P</b>	
PDU Major Components.....	F 1-1
PDU Operation.....	2-13
PMCS Table (Operator) .....	2-7
PMCS Table (Unit).....	4-10
Post-Mission Servicing.....	2-15
Power-On Controls.....	2-3
Power-On Controls.....	F 2-3
Power-On Controls.....	T 2-3
Preparation for Movement .....	2-16

INDEX

Subject	Paragraph, Figure, Table Number
<b>P (Cont)</b>	
Preparation for Storage or Shipment .....	1-5
Preparation for Storage or Shipment (Unit).....	4-57
Preparation for Use .....	2-9
Primary Hydraulic Manifold Assembly Repair.....	5-10
Primary Hydraulic Manifold Assembly Replacement .....	4-36
Procedures .....	4-8
Pump and Crosstube Assembly Chemical Pump Repair.....	5-12
Pump and Crosstube Assembly Chemical Pump Replacement.....	4-43
Pump and Crosstube Assembly Hydraulic Motor and Chemical Pump Assembly Replacement .....	4-42
Pump and Crosstube Assembly Hydraulic Motor Replacement.....	4-44
Pump and Crosstube Assembly Level Switch Replacement.....	4-40
Pump and Crosstube Assembly Repair .....	4-41
Pump and Crosstube Assembly Replacement .....	4-39
Pump and Crosstube Assembly Spray System Control Repair.....	5-14
Pump and Crosstube Assembly Spray System Control Replacement.....	4-45
<b>R</b>	
Repair Parts (Direct Support).....	5-3
Repair Parts (Unit).....	4-3
Reporting Equipment Improvement Recommendations (EIRs).....	1-7
Rotary Atomizer Assembly Repair.....	4-50
<b>S</b>	
Safety, Care, and Handling.....	1-13
Scope.....	1-1
Scope (Expendable).....	E-1
Scope (References).....	A-1
Secondary Hydraulic Manifold Assembly Repair .....	5-9
Secondary Hydraulic Manifold Assembly Replacement.....	4-32
Selecting Nozzles for Calibration.....	G-1
Sling Hook Assembly Replacement.....	4-17
Spark Plug Replacement.....	4-25
Special Instructions .....	2-5
Special Instructions for Administrative Storage .....	4-58
Special Tools, TMDE, and Support Equipment (Direct Support) .....	5-2
Special Tools, TMDE, and Support Equipment (Unit) .....	4-2
Spray Nozzle Replacement/Repair .....	4-47
Starter Motor Repair.....	5-7
Starter Motor Replacement.....	5-6
System Calibration.....	G-3

INDEX

Subject	Paragraph, Figure, Table Number
<b>T</b>	
Tail Fin Replacement .....	4-16
Technical Manuals .....	A-3
Troubleshooting Procedures (Direct Support) .....	5-4
Troubleshooting Procedures (Operator).....	3-2
Troubleshooting Procedures (Unit) .....	4-11
<b>U</b>	
ULV Boom Assembly Repair .....	4-49
ULV Boom Assembly Replacement.....	4-48
ULV Boom Pressure Adjustment .....	F 2-10
ULV System Operational Test .....	F 2-11
Unit Level PMCS .....	T 4-1
Unit Troubleshooting .....	T 4-2
Unpacking (Operator) .....	2-8
Unpacking (Unit) .....	4-4
Uses for Acre/Swath Charts.....	G-5
<b>W</b>	
Warranty Information .....	1-8

**By Order of the Secretary of the Army:**

Official:

MILTON H. HAMILTON  
*Administrative Assistant to the  
Secretary of the Army*  
00196

GORDON R. SULLIVAN  
*General, United States Army  
Chief of Staff*

DISTRIBUTION:

To be distributed in accordance with DA Form 12-25E, (qty rqr block no. 4695)

# The Metric System and Equivalents

## Linear Measure

1 centimeter = 10 millimeters = .39 inch  
 1 decimeter = 10 centimeters = 3.94 inches  
 1 meter = 10 decimeters = 39.37 inches  
 1 dekameter = 10 meters = 32.8 feet  
 1 hectometer = 10 dekameters = 328.08 feet  
 1 kilometer = 10 hectometers = 3,280.8 feet

## Weights

1 centigram = 10 milligrams = .15 grain  
 1 decigram = 10 centigrams = 1.54 grains  
 1 gram = 10 decigrams = .035 ounce  
 1 decagram = 10 grams = .35 ounce  
 1 hectogram = 10 decagrams = 3.52 ounces  
 1 kilogram = 10 hectograms = 2.2 pounds  
 1 quintal = 100 kilograms = 220.46 pounds  
 1 metric ton = 10 quintals = 1.1 short tons

## Liquid Measure

1 centiliter = 10 milliliters = .34 fl. ounce  
 1 deciliter = 10 centiliters = 3.38 fl. ounces  
 1 liter = 10 deciliters = 33.81 fl. ounces  
 1 dekaliter = 10 liters = 2.64 gallons  
 1 hectoliter = 10 dekaliters = 26.42 gallons  
 1 kiloliter = 10 hectoliters = 264.18 gallons

## Square Measure

1 sq. centimeter = 100 sq. millimeters = .155 sq. inch  
 1 sq. decimeter = 100 sq. centimeters = 15.5 sq. inches  
 1 sq. meter (centare) = 100 sq. decimeters = 10.76 sq. feet  
 1 sq. dekameter (are) = 100 sq. meters = 1,076.4 sq. feet  
 1 sq. hectometer (hectare) = 100 sq. dekameters = 2.47 acres  
 1 sq. kilometer = 100 sq. hectometers = .386 sq. mile

## Cubic Measure

1 cu. centimeter = 1000 cu. millimeters = .06 cu. inch  
 1 cu. decimeter = 1000 cu. centimeters = 61.02 cu. inches  
 1 cu. meter = 1000 cu. decimeters = 35.31 cu. feet

## Approximate Conversion Factors

To change	To	Multiply by	To change	To	Multiply by
inches	centimeters	2.540	ounce-inches	Newton-meters	.007062
feet	meters	.305	centimeters	inches	.394
yards	meters	.914	meters	feet	3.280
miles	kilometers	1.609	meters	yards	1.094
square inches	square centimeters	6.451	kilometers	miles	.621
square feet	square meters	.093	square centimeters	square inches	.155
square yards	square meters	.836	square meters	square feet	10.764
square miles	square kilometers	2.590	square meters	square yards	1.196
acres	square hectometers	.405	square kilometers	square miles	.386
cubic feet	cubic meters	.028	square hectometers	acres	2.471
cubic yards	cubic meters	.765	cubic meters	cubic feet	35.315
fluid ounces	milliliters	29.573	cubic meters	cubic yards	1.308
pints	liters	.473	milliliters	fluid ounces	.034
quarts	liters	.946	liters	pints	2.113
gallons	liters	3.785	liters	quarts	1.057
ounces	grams	28.349	liters	gallons	.264
pounds	kilograms	.454	grams	ounces	.035
short tons	metric tons	.907	kilograms	pounds	2.205
pound-feet	Newton-meters	1.356	metric tons	short tons	1.102
pound-inches	Newton-meters	.11296			

## Temperature (Exact)

°F	Fahrenheit temperature	5/9 (after subtracting 32)	Celsius temperature	°C
----	------------------------	----------------------------	---------------------	----

RECOMMENDED CHANGES TO EQUIPMENT TECHNICAL PUBLICATIONS

 <p style="text-align: center;"><i>THEN...JOT DOWN THE DOPE ABOUT IT ON THIS FORM. CAREFULLY TEAR IT OUT, FOLD IT AND DROP IT IN THE MAIL.</i></p>		SOMETHING WRONG WITH PUBLICATION		
		FROM: (PRINT YOUR UNIT'S COMPLETE ADDRESS)		
		DATE SENT		
PUBLICATION NUMBER		PUBLICATION DATE	PUBLICATION TITLE	
BE EXACT PIN-POINT WHERE IT IS				
PAGE NO.	PARA- GRAPH	FIGURE NO.	TABLE NO.	<p style="text-align: center; font-weight: bold;">IN THIS SPACE, TELL WHAT IS WRONG AND WHAT SHOULD BE DONE ABOUT IT.</p>
PRINTED NAME, GRADE OR TITLE AND TELEPHONE NUMBER			SIGN HERE	

**DA** FORM 1 JUL 79 **2028-2**

PREVIOUS EDITIONS ARE OBSOLETE.

P.S.--IF YOUR OUTFIT WANTS TO KNOW ABOUT YOUR RECOMMENDATION MAKE A CARBON COPY OF THIS AND GIVE IT TO YOUR HEADQUARTERS.

